

## 50 & 100W, 14.4 to 36V Input DC-DC Converters

<https://product.tdk.com/en/power/cn-a>  
[www.emea.lambda.tdk.com/cn-a](http://www.emea.lambda.tdk.com/cn-a)



The rugged 50 and 100W quarter brick CN-A24 series of isolated DC-DC converters operate from a 14.4 to 36V (40Vdc peak) input. With an input to baseplate isolation of 2,000Vac and 3,000Vac input to output, the series is designed for use on 24V nominal input rail, vehicle and battery powered systems. In addition, the baseplate cooled modules meet the rolling stock IEC 61373 Category 1, Class B shock / vibration standards. As standard, the CN-A24 series features remote sense, remote on/off and output voltage adjustment. The board coating option provides assistance in complying with EN 50155 and IEC 60571.

Features	Benefits
• Wide Input Range	• Supports 24V Input Rail, Vehicle and Battery Powered Systems
• Quarter Brick Packages	• Less Board Area Needed
• Certified to IEC 62368-1, Designed to Meet IEC 61373	• Easier System Compliance
• Full Power at 100°C Baseplate Temperatures	• Greater Useable Power

Model Selector						
Model	Output Voltage (V)	Output Voltage Adjustment (V)	Output Current (A)	Maximum Power (W)	Input Current (A) (24V input, 100% load)	Efficiency (%) <sup>(1)</sup>
CN50A24-5	5	4.5 - 6.0	10	50.0	2.48	85
CN100A24-5	5	4.5 - 6.0	20	100.0	4.91	86
CN50A24-12	12	10.8 - 13.2	4.2	50.4	2.47	86
CN100A24-12	12	10.8 - 13.2	8.4	100.8	4.83	88
CN50A24-24	24	21.6 - 26.4	2.1	50.4	2.47	86
CN100A24-24	24	21.6 - 26.4	4.2	100.8	4.83	88

### Part Numbering Scheme

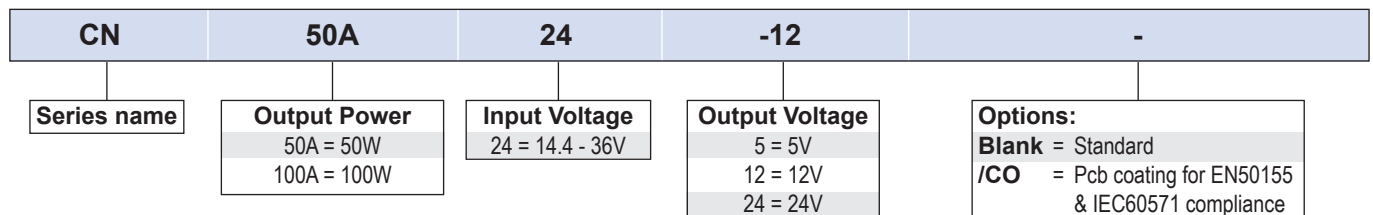

Related Products		
Type	Part Number	Description
Heat Sink	HAQ-10T	25mm transverse fins

Specifications		
Model	CN-A24	
<b>Input</b>		
Input Voltage Range	Vdc	14.4 - 36 (40 for 3s)
Efficiency	-	See model selector table
Conducted & Radiated EMI	-	EN55011/EN55032-A, FCC Class A, VCCI-A (External components are required, consult Evaluation Data)
Immunity	-	See model immunity table below
Safety Certifications and Markings	-	IEC/UL/CSA/EN62368-1, 60950-1, CE Mark and UKCA Mark

Immunity				
Test	Standard	Test Level	Criteria	Notes
ESD	EN61000-4-2	Air ± 8kV and contact ± 6kV	A	See IEC61000 immunity test report on website for external filtering circuitry
Radiated Susceptibility	EN61000-4-3	80M -1GHz: 10V/m	A	
Electrical Fast Transient Burst	EN61000-4-4	± 2kV	A	
Surge	EN61000-4-5	Common, Normal ± 2kV	A	
Conducted Susceptibility	EN61000-4-6	10Vrms	A	
Magnetic Fields	EN61000-4-8	30A/m	A	

Specifications		
Model	CN-A24	
<b>Output</b>		
Output Voltage Tolerance	%	±1
Output Voltage Adjustment	-	See model selector
Line Regulation	mV	5V: 20, 12V: 48, 24V: 96
Load Regulation	mV	5V: 40, 12V: 96, 24V: 192
Switching Frequency	kHz	360
External Load Capacitance	uF	10,000
Ripple & Noise	mV	5V: 100, 12V: 150, 24V: 240
Temperature Coefficient	%/°C	0.02
Minimum Load	-	No minimum load required
Overcurrent Protection	%	105 - 140. Auto recovery
Overvoltage Protection	%	125 - 145 (2)
Overtemperature Protection	°C	Operates at 105-120 baseplate. Auto recovery.
Remote Sense	-	Yes
Remote On/Off	-	Negative Logic ON: Short (<0.8V), OFF: Open or 4 to 35V
Parallel Operation	-	Not possible
<b>Environmental</b>		
Operating Temperature	°C	-40 to +100 (Baseplate)
Storage Temperature	°C	-40 to +100
Humidity (non condensing)	%RH	5 - 95 (Operating & Storage)
Cooling	-	Conduction
Altitude	m	3,000
Withstand Voltage (For 1 minute)	Vac	Input to baseplate 2,000, input to output 3,000, output to baseplate 500 for 1 minute
Isolation Resistance	MΩ	>100 at 25°C, 70%RH & Output - Baseplate 500VDC
Vibration (Non operating)	-	10-55Hz (Sweep for 1min.) Amplitude 0.825mm Constant (Maximum 49.0m/s <sup>2</sup> ) X,Y,Z 1 hour each. IEC61373 Category 1, Grade B
Shock (Non operating)	-	196.1m/s <sup>2</sup> . IEC61373 Category 1 Grade B
<b>Other</b>		
		<b>CN50-A24</b>   <b>CN100-A24</b>
Weight (Typ)	g	70
Size (LxWxH)	mm	57.9 x 36.8 x 12.7
Size (LxWxH)	Inches	2.28 x 1.45 x 0.5
MTBF - Telcordia SR-332 issue 3*	Hours	1,951,887   1,918,395
Warranty	yrs	5

Notes

See website for detailed specifications, test methods and installation manual

\* Full load, 24V output, 40°C baseplate temperature. See reliability data on website for other temperatures.

(1) 24V model, 24Vdc Input, maximum output current, 40°C baseplate temperature

(2) Cycle input or remote on/off to reset

## Basic Connection for the CN-A24

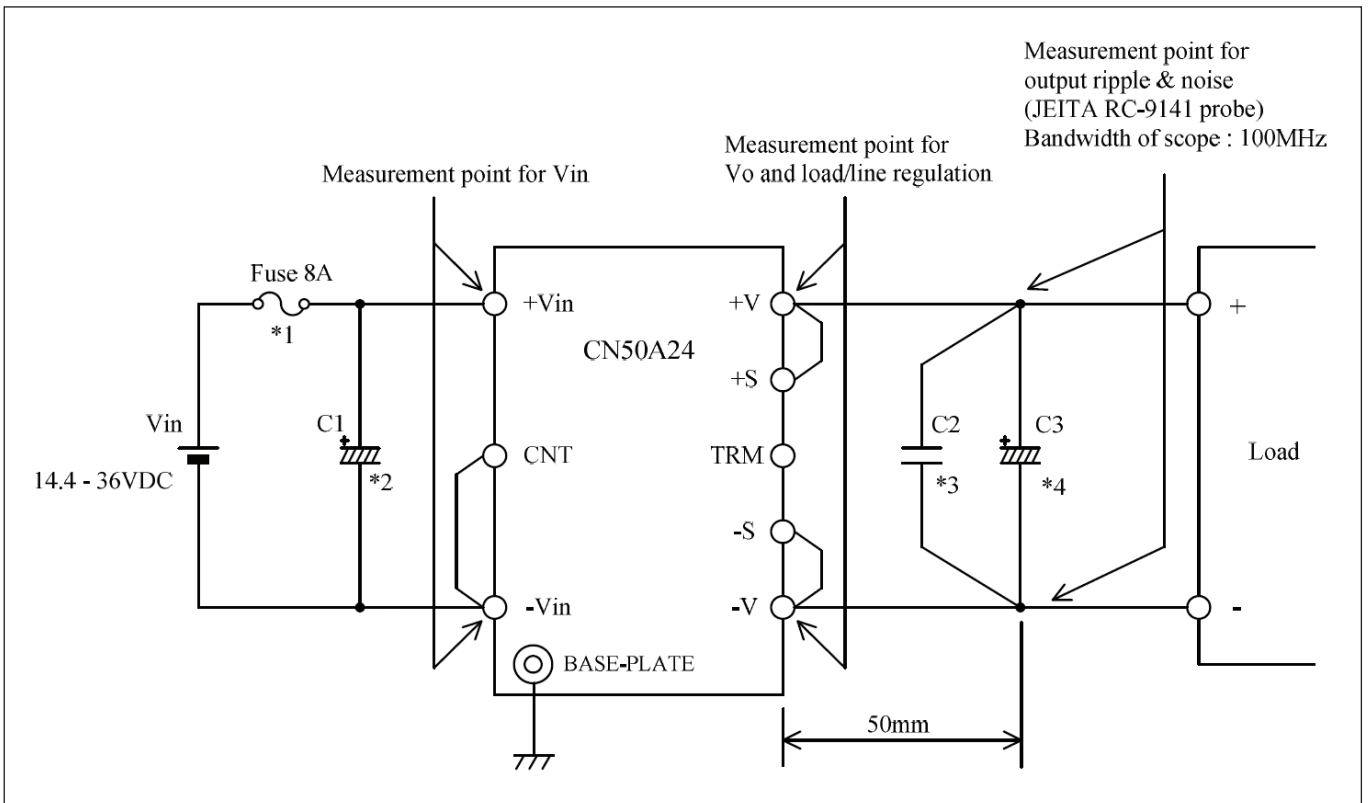

## Outline Drawing CN-A24

