

Industries & Applications



Automation



Industrial



Semi-Fab



Renewable



Comms



Test

ePLAN[®]
data portal

Features & Benefits

- ▶ Operation with AC or DC voltage for a wide range of applications
- ▶ Parallel mode switch to activate load balancing behaviour
- ▶ Integrated GDT for ultimate process stability
- ▶ Very low inrush energy peak (I^2t) saves cost for input line protection
- ▶ Screw or push-in terminals available to serve individual application needs
- ▶ High efficiency contributes to an eco-friendly energy footprint
- ▶ DC-OK and inhibit relay contacts for professional integration into applications control architecture
- ▶ Comprehensive boost power capabilities support start-up into heavy loads
- ▶ Exceeds regulatory EMC standards on radiated emission (Class B), surge immunity and fast transients



Technical data abstract¹

Output voltage	nom.	12V _{DC}
Adjustment range	nom.	11.4 .. 15V _{DC}
Output current	nom.	10A
Boost current 1	max.	12A / continuous
Boost current 2	max.	14.5A / 600s
Overload behaviour		CC + Intermittent mode (Hiccup)
Input voltage AC	nom.	3x380 .. 500V _{AC}
Input voltage AC range	max.	3x342 .. 575V _{AC}
Frequency range	max.	47 .. 63Hz
Inrush current AC ²	typ.	25 / 30A
Inrush energy AC ²	typ.	0.3 / 0.6A ² s
Input voltage DC	max.	450 .. 810V _{DC}
Inrush current DC ³	typ.	38 / 41 / 53A <2ms
Inrush energy DC ³	typ.	0.7 / 0.8 / 1.3A ² s
Output power	nom.	120W
Boost power 1 ⁵	max.	144W / continuous
Boost power 2 ⁵	max.	174W / 600s
Power factor	typ.	0.5
Conversion efficiency AC ²	typ.	89.4 / 89.1%
Power losses AC ²	typ.	14.2 / 14.7W
No-load consumption AC ²	max.	1.7 / 2.1W
Conversion efficiency DC ³	typ.	92.1 / 92.0 / 90.9%
Power losses DC ³	typ.	10.3 / 10.4 / 12.0W
No-load consumption DC ³	max.	1.9 / 2.3 / 2.8W
Ambient operating temperature	max.	-25 .. +70°C (-13 .. +158°F)
	nom.	-25 .. +55°C (-13 .. +131°F)
Service lifetime ²	min.	131 400 / 131 400hrs
Service life MTBF ⁴	min.	5.7M / 1.8M hrs
Width x Height x Depth		55 x 129 x 138.2mm (2.17 x 5.08 x 5.44in)
Weight		660g (1.46lb)

¹ All values refer to STC unless otherwise stated | ² 400 / 500V_{AC} | ³ 540 / 650 / 800V_{DC} | ⁴ 50% / 100% P_{out,nom} |

⁵ See duty cycle 1/2 under „5. Performance“ on page 10

Certifications & Approvals



IECEE
CB SCHEME

IEC EN 61010-1
IEC EN 61010-2-201
IEC EN 62368-1 (Ed.3)



UL
LISTED

UL CSA 61010-1
UL CSA 61010-2-201
E356563



UL
US

UL CSA 62368-1 (Ed.3)
E511889

Compliance & Registration



EU Low Voltage Dir. 2014/35/EU
EU EMC Dir. 2014/30/EU
EU RoHS Dir. 2011/65/EU



Safety and EMC Reg. 2016
Hazard. Substances Reg. 2012



China RoHS Law SJ/T 11363-2006



Commercial information

Order codes	DRB120-12-3-A0 DRB120-12-3-A1
HS code	8504408390
Life-cycle status	Active
Product revision	G01
Single package	
Width	65mm (2.56in)
Height	193mm (7.60in)
Depth	166mm (6.54in)
Gross weight	780g (1.72lb)
Bulk package	
Width	340mm (13.39in)
Height	205mm (8.07in)
Depth	405mm (15.94in)
Quantity	10 units
Pallet	
Width	1000mm (39.37in)
Length	1200mm (47.24in)
Quantity	240 units
Manufacturer warranty	3 years

Model selector

Model name	Output Power	Output Voltage	Feature
DRB120-12-3-A0	120W	12V _{DC}	Screw terminals
DRB120-12-3-A1	120W	12V _{DC}	Push-in terminals
DRB120-24-3-A0	120W	24V _{DC}	Screw terminals
DRB120-24-3-A1	120W	24V _{DC}	Push-in terminals
DRB120-24-3-A6	120W	24V _{DC}	Screw terminals, conformal coating
DRB120-24-3-A7	120W	24V _{DC}	Push-in terminals, conformal coating
DRB240-24-3-A0	240W	24V _{DC}	Screw terminals
DRB240-24-3-A1	240W	24V _{DC}	Push-in terminals
DRB240-24-3-A6	240W	24V _{DC}	Screw terminals, conformal coating
DRB240-24-3-A7	240W	24V _{DC}	Push-in terminals, conformal coating
DRB240-48-3-A0	240W	48V _{DC}	Screw terminals
DRB240-48-3-A1	240W	48V _{DC}	Push-in terminals
DRB240-48-3-A7	240W	48V _{DC}	Push-in terminals, conformal coating
DRB480-24-3-A0	480W	24V _{DC}	Screw terminals
DRB480-24-3-A1	480W	24V _{DC}	Push-in terminals
DRB480-24-3-A6	480W	24V _{DC}	Screw terminals, conformal coating
DRB480-24-3-A7	480W	24V _{DC}	Push-in terminals, conformal coating
DRB480-48-3-A0	480W	48V _{DC}	Screw terminals
DRB480-48-3-A1	480W	48V _{DC}	Push-in terminals
DRB480-48-3-A7	480W	48V _{DC}	Push-in terminals, conformal coating
DRB480-72-3-A0	480W	72V _{DC}	Screw terminals
DRB480-72-3-A1	480W	72V _{DC}	Push-in terminals
DRB960-24-3-A0	960W	24V _{DC}	Screw terminals
DRB960-24-3-A1	960W	24V _{DC}	Push-in terminals
DRB960-24-3-A6	960W	24V _{DC}	Screw terminals, conformal coating
DRB960-24-3-A7	960W	24V _{DC}	Push-in terminals, conformal coating
DRB960-48-3-A0	960W	48V _{DC}	Screw terminals
DRB960-48-3-A1	960W	48V _{DC}	Push-in terminals
DRB960-48-3-A7	960W	48V _{DC}	Push-in terminals, conformal coating
DRB960-72-3-A0	960W	72V _{DC}	Screw terminals
DRB960-72-3-A1	960W	72V _{DC}	Push-in terminals



Add-ons and accessories



DRM redundancy modules

For building fault tolerant 12/24V systems, DRM redundancy modules can be used to decouple 1+1 power supplies.

DRM40

40A output, 2x20A input, screw terminals, DC OK and balancing LEDs

DRM40B

40A output, 2x20A input, screw terminals

www.emea.lambda.tdk.com/uk/products/drm40



DDSM programmable DC/DC converter

Isolated buck-boost converter with a wide input/output voltage range.

DDSM120-0555-R0

5A output at 5.55V, input 11..52V, push-in terminals, display, DC OK, USB

DDSM240-0555-R0

10A output at 5.55V, input 11..52V, push-in terminals, display, DC OK, USB

www.emea.lambda.tdk.com/uk/products/ddsm



DDA DC/DC converter

Non-isolated step-down converter for creating additional DC bus voltages from a single DC input source.

DDA250

Single output 20A at 3.3..15V, input 9..53V, DC OK LED, screw terminals

DDA325

Dual output 14A at 3.3..24V and 8A at -3.3..-24V, input 9..40V, DC OK LEDs, screw terminals

DDA500

Dual output 2x20A at 3.3..15V, input 9..53V, DC OK LEDs, screw terminals

www.emea.lambda.tdk.com/uk/products/dda



DUSH DC-UPS

In mission critical applications, the DUSH serves as a backup solution to deliver power from a battery.

DUSH960-1248-0M

20A input/output/battery, 12..48V programmable, buck-boost converter, battery interface, Modbus/RTU, LCD, 5A AUX output, push-in terminals

DUSH960-1248-1M

20A input/output/battery, 12..48V programmable, buck-boost converter, battery interface, Modbus/RTU, LED indication, push-in terminals

www.emea.lambda.tdk.com/uk/products/dush



Index

1.	General	6
1.1	Description of user elements	6
2.	Electrical output	7
3.	Electrical input AC	8
4.	Electrical input DC	9
5.	Performance	10
5.1	AC input operation	11
5.2	DC input operation	11
6.	Ambient conditions	12
7.	Reliability and Service lifetime	14
8.	Dimensions & Mechanical data	14
9.	Installation clearances	16
10.	Wiring & Connection	16
11.	Signaling & Control	17
12.	Block diagram	18
13.	Device protection	18
14.	Electrical Safety	19
14.1	Overvoltage category design	19
14.2	Insulation strength.....	19
14.3	HIPOT test	20
15.	Electromagnetic immunity	21
16.	Electromagnetic emission	21
17.	Certifications & Approvals	22
18.	Designed to meet	22
19.	Compliance & Registration	22
20.	Application notes	23
20.1	Parallel Operation	23
20.2	Series operation.....	24
20.3	Two-phase operation	25



List of abbreviations

avg.	<i>average</i>	The arithmetic average calculated from a row of values.
CC		Constant output current
CGD		Corner grounded delta (AC power system)
chap.		Chapter
Dir.		Directive
eCap		Electrolytic capacitor
EMC		Electromagnetic Compatibility
GDT		Gas discharge tube
Iout		DC output current under a particular operating condition
Iout_boost		Increase output current above Iout_nom that can be delivered for a limited time.
Iout_nom		Continuous nominal DC output current under STC.
Iout_ol		Max. intermittent DC output current in an overload situation and a shortfall of Uset.
Iout_sc		Max. short circuit DC output current
ITU		International Telecommunication Union
max.	<i>maximum</i>	The maximum value which a parameter can assume, or which must not be exceeded.
MCB		Miniature circuit breaker
min.	<i>minimum</i>	The minimum value which a parameter can assume, or must not be fallen below.
MTBF		Mean Time Between Failure
nom.	<i>nominal</i>	The ideal or reference value of a technical parameter which is guaranteed under STC. All nominal values in this document refer to each other and represent the general specification of the device.
OCP		Overcurrent protection
OTP		Overtemperature protection
OVP		Overvoltage protection
PELV		Protective Extra Low Voltage
Pout		Output power under a particular operating condition with reference to Pout_nom
Pout_boost		Increased output power above Pout_nom that can be delivered for a limited time.
Pout_nom		Nominal output power
ppb		parts per billion
PSU		Power supply unit
Reg.		Regulation
SELV		Safety Extra Low Voltage
STC		Standard test conditions (see „1. General“ on page 6)
typ.	<i>typical</i>	The typical value of a parameter is not guaranteed but can be assumed under STC. The min. or max. value must be determined during the engineering process of the end application.
Uout		DC output voltage under a particular operating condition
Uout_nom		Nominal DC output voltage
Uset		Manually set output voltage via voltage potentiometer
UVP		Undervoltage protection
Uin		AC or DC input voltage under a particular operating condition
/		Separator between two values. The conditions to which the values refer can be found in the last column of the table.
..		Specifies a range of values.
<		The parameter is less than or equal to the specified value
>		The parameter is greater than or equal to the specified value

Table data structure

X. Technical category

Technical parameter	Characteristic (optional)	Values	Condition (optional)
---------------------	---------------------------	--------	----------------------

1. General

Proper handling of the product

The faultless and safe operation of the products requires proper transport, proper storage, set-up, assembly, installation, commissioning, operation and maintenance. The permissible ambient conditions must be observed. Instructions in the associated documentation must be observed.

Protection enclosure required

The device must be installed in a protective housing or control cabinet to which only qualified personnel have access.

Humid environments

Do not operate the device in a damp environment or in an environment where condensation is likely to occur.

Switch or circuit-breaker mounting position

A switch or circuit-breaker must be mounted near the equipment.

Observe country-specific regulations

In addition to the product documentation, the relevant country-specific regulations for the installation of the device must be observed.

Prohibited electrical/mechanical modifications

The product must not be modified in any way electrically or mechanically. Modifications can result in fatal injuries and damage to property.

Expiry of the manufacturer's warranty

The power supply is maintenance-free. Repairs can only be carried out by the manufacturer. Opening the housing voids the manufacturer's warranty.

Use of third-party products

If third-party products and components are used for power or voltage increase, buffering, EMC filtering, redundancies or load protection, it must be in accordance with the TDK-Lambda product specification.

Standard test conditions

Unless otherwise stated, all values are specified in normal mounting position, at full load, nominal input and output voltages, 25°C (131°F) ambient temperature and a run-in time of 5 minutes.

1.1 Description of user elements

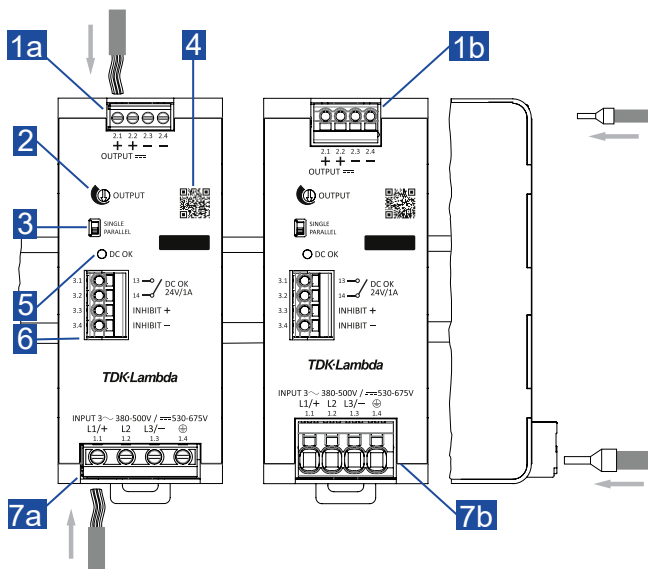

- 1a Screw terminal, DC output
- 1b Push-in terminal, DC output
- 2 Single turn potentiometer for adjusting the output voltage
- 3 Dip-switch for single or parallel operation
- 4 Web link to product documentation
- 5 Green DC-OK status LED
- 6 Push-in terminal for signal contacts
- 7a Screw terminal, AC or DC input
- 7b Push-in terminal, AC or DC input

i For more detailed information on the input/output wiring and the connection of the signalling contacts, please refer to „10. Wiring & Connection“ on page 16.

Fig. 1: Description of user elements

2. Electrical output

Output voltage [U _{out_nom}]	nom.	12V _{DC}	
Adjustment range [U _{set}]	nom.	11.4 .. 15V _{DC}	
Adjustment tolerance	max.	±3%	at upper/lower end position of voltage potentiometer
Factory default		12V _{DC} (±0.1%)	
Output current [I _{out_nom}]	nom.	10A	
Boost current 1 [I _{out_boost1}]	max.	12A / continuous	
Boost current 2 [I _{out_boost2}]	max.	14.5A / 600s	
Overload behaviour		Constant current + Intermittent mode (Hiccup)	
SC hiccup current	max.	14.5A / 0.3s	
Short-circuit proof		yes, with auto-recovery	
Instant SC current [I _{out_sc}]	max.	50A <1ms	
Start-up delay	typ.	2.5s	
Rise time	typ.	10ms	0% P _{out_nom}
	typ.	20ms	100% P _{out_nom} , resistive load
Voltage overshoot	typ.	1.3V _{DC}	
Fall time	typ.	20ms	
Output capacitance	max.	11 470µF	
Capacitive load start-up	max.	10 000µF	
Feedback voltage	max.	25V _{DC}	
Feedback energy	max.	2.8J	
Return current	max.	20mA	OFF mode
Line regulation	max.	0.06%	
Load regulation	max.	1.2%	Parallel mode
	max.	3.8%	
Dynamic response	typ.	±400mVpp	10..100% P _{out_nom} , transient frequency 10Hz
Ripple & noise voltage*	max.	10mVpp	+25 .. +70°C _{amb}
	max.	20mVpp	-25 .. +25°C _{amb}

*The measurement was performed with a short twisted pair cable using a 120µF eCap and a 0.1µF cCap connected in parallel. A bandwidth limit of 20MHz is required.

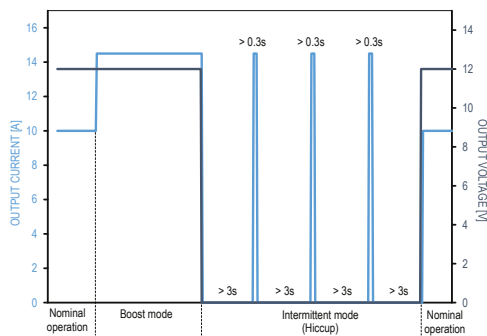

Fig. 2: Output current and voltage in different operation modes

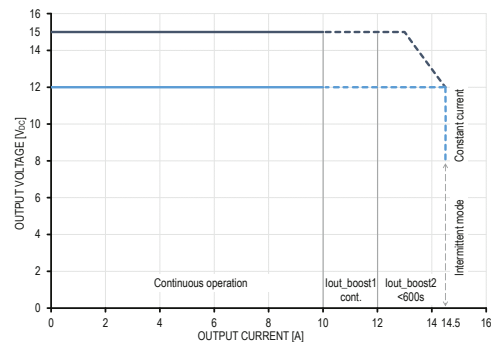

Fig. 3: Output current in nominal and boost operation up to 55°C_{amb}

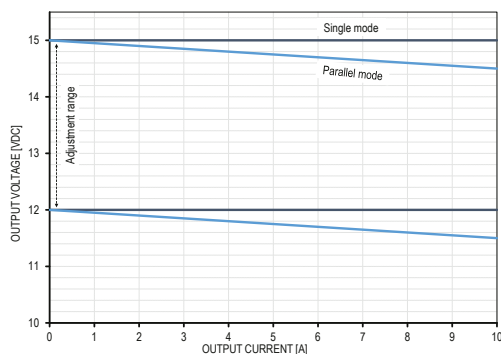

Fig. 4: Voltage drop in parallel mode as a function of the output current

Unless otherwise stated, all values are specified in normal mounting position, at full load, nominal input and output voltages, 25°C (77°F) ambient temperature and a run-in time of 5 minutes.

3. Electrical input AC

AC power systems	TN, TT, IT (IEC 61010-1), CGD		
Mains Frequency	<i>nom.</i>	50 / 60Hz	
Frequency range	<i>max.</i>	47 .. 63Hz	
Input voltage	<i>nom.</i>	3x380 .. 500V _{AC}	3AC, PE
	<i>max.</i>	3x342 .. 575V _{AC}	
Withstand voltage	<i>max.</i>	620V _{AC} / 5s	
Turn-ON voltage	<i>typ.</i>	310V _{AC}	
Turn-OFF voltage	<i>typ.</i>	275V _{AC}	
Input current	<i>max.</i>	3x0.5A	According safety approval reports
Input current RMS	<i>typ.</i>	3x0.36 / 3x0.31A	
Hold-up time	<i>min.</i>	20 / 40ms	400 / 500V _{AC}
Crest factor	<i>typ.</i>	3.3 / 3.5	400 / 500V _{AC}
Inrush current	<i>typ.</i>	25 / 30A <3ms	400 / 500V _{AC} , 25°C _{amb} , cold start
Inrush energy	<i>typ.</i>	0.3 / 0.6A ² s	400 / 500V _{AC} , 25°C _{amb} , cold start
Input capacitance	<i>max.</i>	34μF	

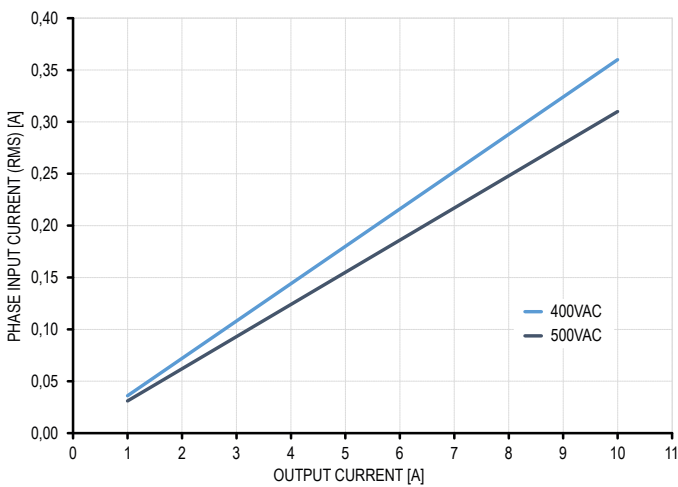

Fig. 5: Typical AC input current per phase as a function of the output current

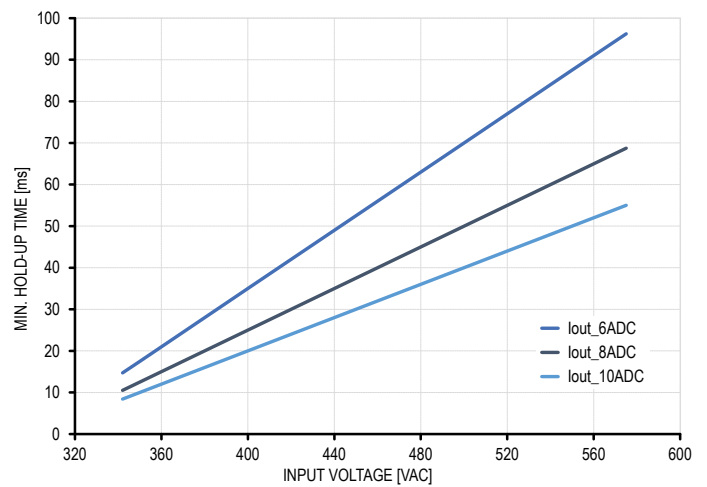

Fig. 6: Hold-up times under different load conditions as a function of the AC input voltage

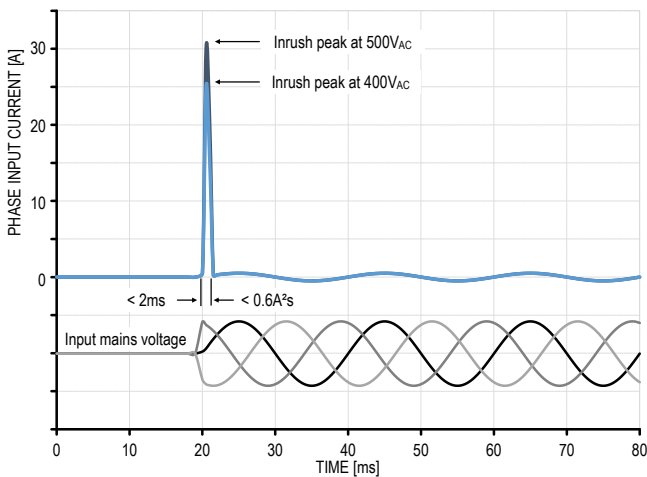

Fig. 7: AC inrush current and energy during start-up phase

4. Electrical input DC

The safety assessment for operation with DC input voltage was performed in accordance with the international standard IEC 62477-1.

Input voltage	<i>nom.</i> 530 .. 675V _{DC} <i>max.</i> 450 .. 810V _{DC}	external DC fuse required, see „Device protection“ on page 18
Withstand voltage	<i>max.</i> 880V _{DC} / 5s	
Turn-ON voltage	<i>typ.</i> 430V _{DC}	
Turn-OFF voltage	<i>typ.</i> 369V _{DC}	
Hold-up time	<i>min.</i> 16 / 32 / 53ms	540 / 650 / 800V _{DC}
Input current	<i>max.</i> 0.5A <i>typ.</i> 0.24 / 0.20 / 0.16A	540 / 650 / 800V _{DC}
Inrush current	<i>typ.</i> 38 / 41 / 53A <2ms	540 / 650 / 800V _{DC} , 25°C _{amb} , cold start
Inrush energy	<i>typ.</i> 0.7 / 0.8 / 1.3A ² s	540 / 650 / 800V _{DC} , 25°C _{amb} , cold start
Input capacitance	<i>max.</i> 34μF	

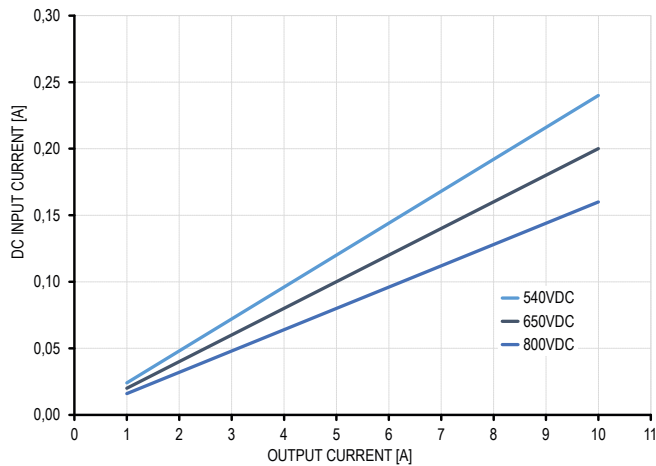

Fig. 8: Typical DC input current as a function of the output current

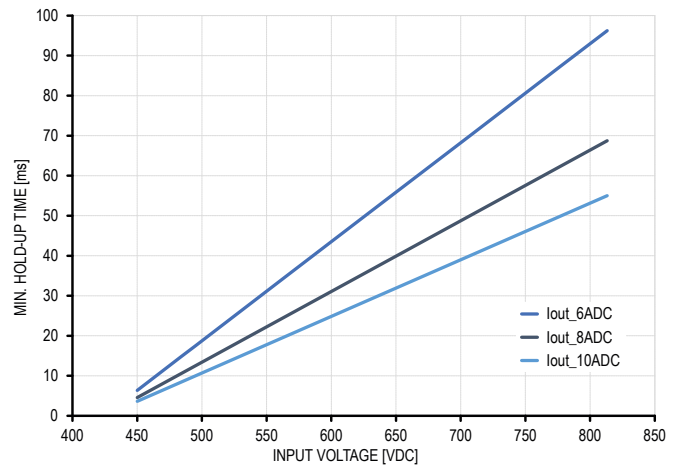

Fig. 9: Hold-up times under different load conditions as a function of the DC input voltage

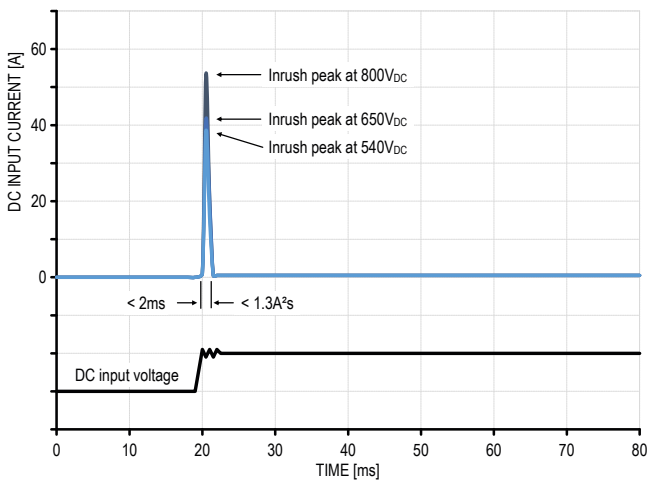

Fig. 10: DC Inrush current and energy during start-up phase

5. Performance

Output power [Pout_nom]	nom.	120W	
Boost power 1 [Pout_boost1]	max.	144W / continuous	
Boost power 2 [Pout_boost2]	max.	174W / 600s	
Duty cycle 1	max.	1.00	
Duty cycle 2	max.	0.35	
Dropped phase power	max.	120W	2x380..500V _{AC} , not compliant with IEC EN 61000-3-2 harmonic currents
Apparent input power	typ.	268 / 269VA	400 / 500V _{AC}
Active input power	typ.	134 / 135W	400 / 500V _{AC}
Reactive input power	typ.	232 / 233Var	400 / 500V _{AC}
Power factor	typ.	0.5	

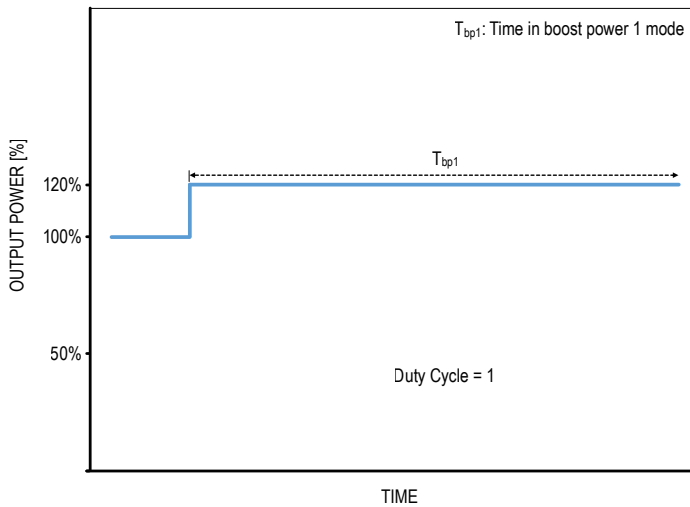

Fig. 11: Period and frequency of use of boost power 1 in normal mounting position

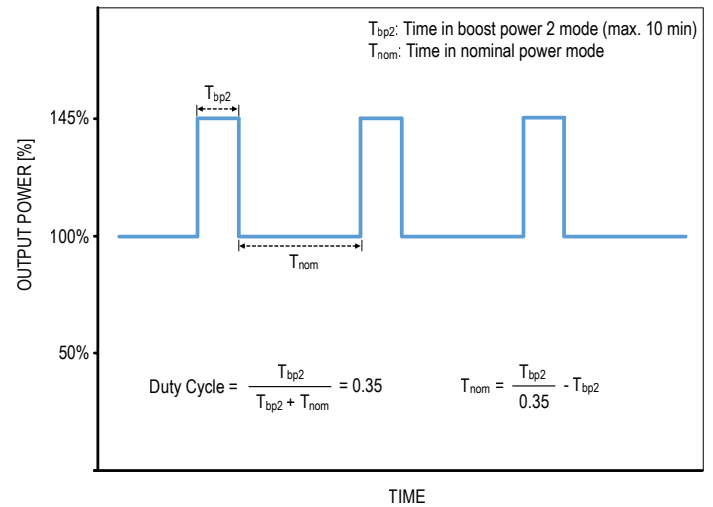

Fig. 12: Period and frequency of use of boost power 2 in normal mounting position

5.1 AC input operation

Conversion efficiency	<i>typ.</i> 89.4 / 89.1%	400 / 500V _{AC} , 100% P _{out_nom}
	<i>avg.*</i> 87.7 / 89.8%	400 / 500V _{AC} , 25.. 100% P _{out_nom}
Power losses	<i>typ.</i> 14.2 / 14.7W	400 / 500V _{AC} , 100% P _{out_nom}
	<i>avg.*</i> 17.1 / 17.5W	400 / 500V _{AC} , 25.. 100% P _{out_nom}
No-load consumption	<i>max.</i> 1.7 / 2.1W	400 / 500V _{AC} , 0% P _{out_nom}
Stand-by consumption	<i>max.</i> 1.2 / 1.6W	400 / 500V _{AC} , Inhibit status HIGH (see Fig. 28)

*Average efficiency under 25%, 50%, 75% and 100% load conditions, according to eco-design requirements of EU commission regulation 2019/1782.

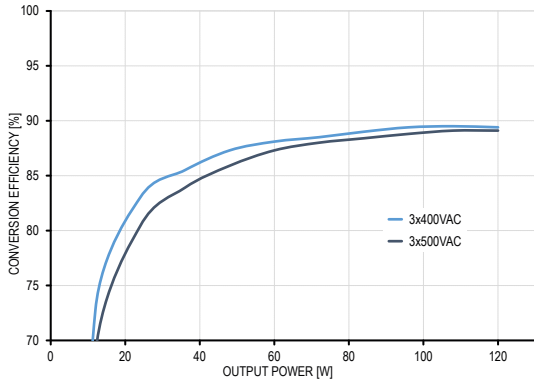

Fig. 13: AC conversion efficiency as a function of the output power

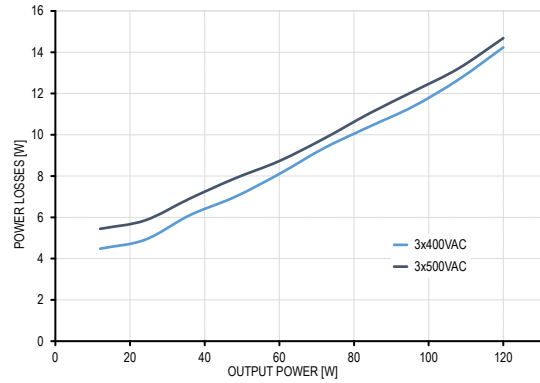

Fig. 14: AC power losses as a function of the output power

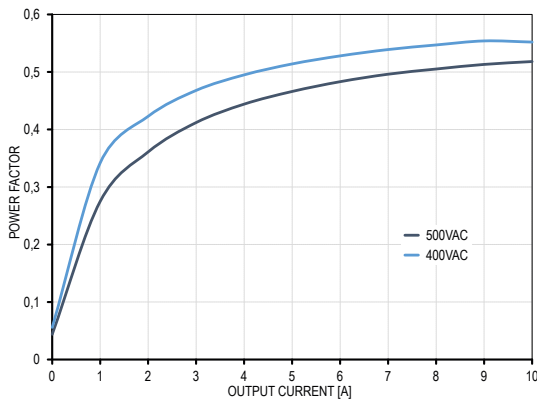

Fig. 15: Input power factor as a function of the output current

5.2 DC input operation

Conversion efficiency	<i>typ.</i> 92.1 / 92.0 / 90.9%	540 / 650 / 800V _{DC} , 100% P _{out_nom}
	<i>avg.*</i> 89.5 / 88.6 / 87.1%	540 / 650 / 800V _{DC} , 25.. 100% P _{out_nom}
Power losses	<i>typ.</i> 10.3 / 10.4 / 12.0W	540 / 650 / 800V _{DC} , 100% P _{out_nom}
	<i>avg.*</i> 14.1 / 15.4 / 17.8W	540 / 650 / 800V _{DC} , 25.. 100% P _{out_nom}
No-load consumption	<i>max.</i> 1.9 / 2.3 / 2.8W	540 / 650 / 800V _{DC} , 0% P _{out_nom}
Stand-by consumption	<i>max.</i> 1.3 / 1.8 / 2.4W	540 / 650 / 800V _{DC} , Inhibit status HIGH (see Fig. 28)

*Average efficiency under 25%, 50%, 75% and 100% load conditions, according to eco-design requirements of EU commission regulation 2019/1782.

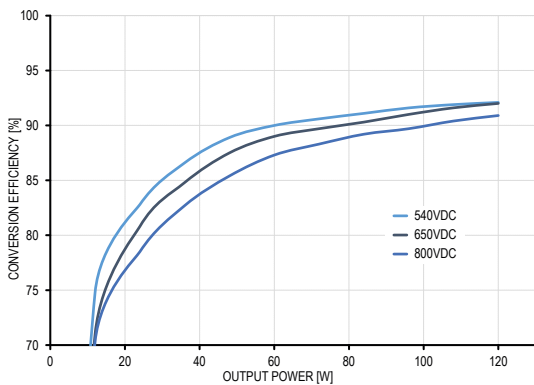

Fig. 16: DC conversion efficiency as a function of the output power

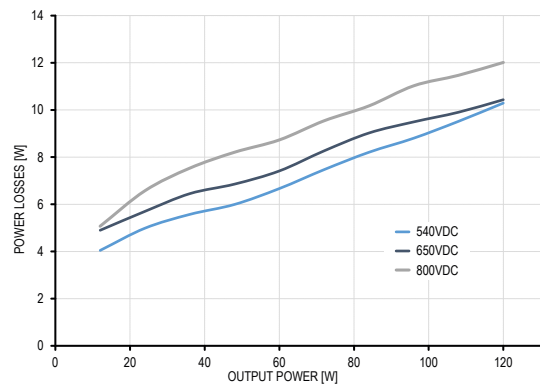

Fig. 17: DC power losses as a function of the output power

Unless otherwise stated, all values are specified in normal mounting position, at full load, nominal input and output voltages, 25°C (77°F) ambient temperature and a run-in time of 5 minutes.

6. Ambient conditions

Ambient storage temperature	<i>max.</i>	-40 .. +85°C _{amb} (-40 .. +185°F _{amb})	
Ambient operating temperature	<i>max.</i>	-25 .. +70°C _{amb} (-13 .. +158°F _{amb})	normal mounting position, >55°C _{amb} (>131°F _{amb}) rotated ±90° around X or Y axis rotated 180°
	<i>nom.</i>	-25 .. +55°C _{amb} (-13 .. +131°F _{amb})	
	<i>nom.</i>	-25 .. +45°C _{amb} (-13 .. +113°F _{amb})	
	<i>nom.</i>	-25 .. +45°C _{amb} (-13 .. +113°F _{amb})	
Power derating*	<i>min.</i>	2.0W/°C _{amb} (1.11W/°F _{amb})	normal mounting position, >55°C _{amb} (>131°F _{amb}) rotated ±90° around X or Y axis, >45°C _{amb} (>113°F _{amb}) rotated 180°, >45°C _{amb} (>113°F _{amb})
	<i>min.</i>	3.4W/°C _{amb} (1.89W/°F _{amb})	
	<i>min.</i>	3.4W/°C _{amb} (1.89W/°F _{amb})	
Cooling concept		Natural convection	
Start-up temperature	<i>max.</i>	-40°C _{amb} (-40°F _{amb})	
Relative storage humidity IEC 60068-2-30	<i>max.</i>	95%	non-condensing
Relative operation humidity IEC 60068-2-30	<i>max.</i>	95%	non-condensing
Operating altitude	<i>nom.</i>	3000mASL (9842ftASL)	not UL approved, reduced OVC
	<i>max.</i>	6000mASL (19685ftASL)	
Percentage power derating	<i>min.</i>	5% per 1000m (5% per 3281ft)	>3000mASL (>9842ftASL)
Temperature derating	<i>min.</i>	5°C per 1000m (9°F per 3281ft)	>3000mASL (>9842ftASL)
Atmospheric pressure	<i>nom.</i>	689hPa	
	<i>max.</i>	469 .. 1070hPa	
Pollution degree		2	
Vibration sinusoidal IEC 60068-2-6		2g / 10 .. 500Hz, 1 hour/direction X,Y,Z	non-operating, mounted on DIN rail
Shock test sinusoidal halfwave IEC 60068-2-27		30g / 11ms ±5ms, 3 bumps/direction, 9 bumps total	non-operating, mounted on DIN rail
Audible noise		Some audible noise may be heard during no load, overload or short circuit.	

*Not actively controlled

i For altitudes above 3000mASL (9842ftASL) the next lower OVC must be considered.

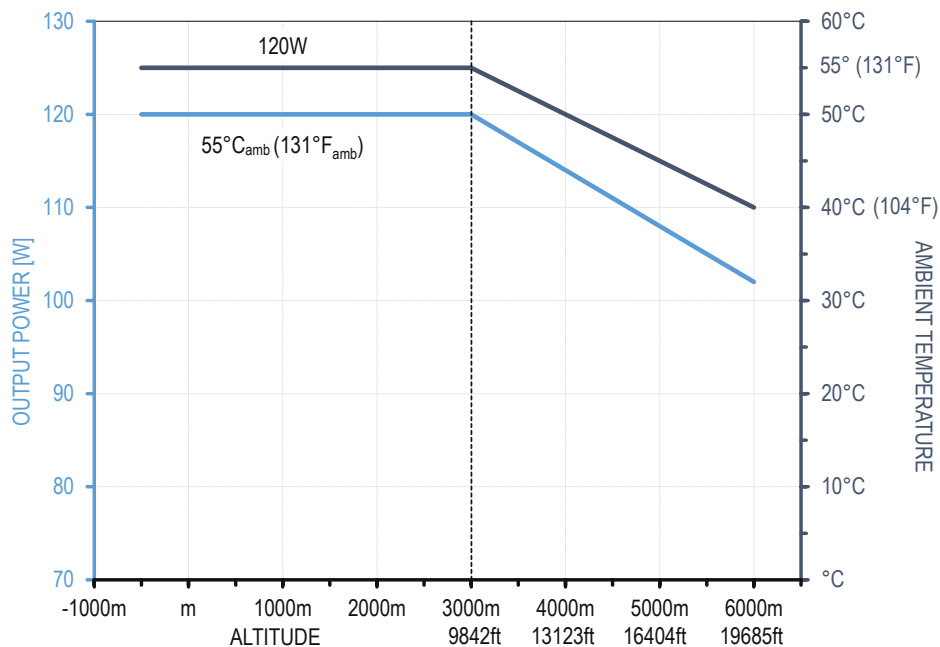

Fig. 18: Output power and ambient temperature derating at increasing altitudes

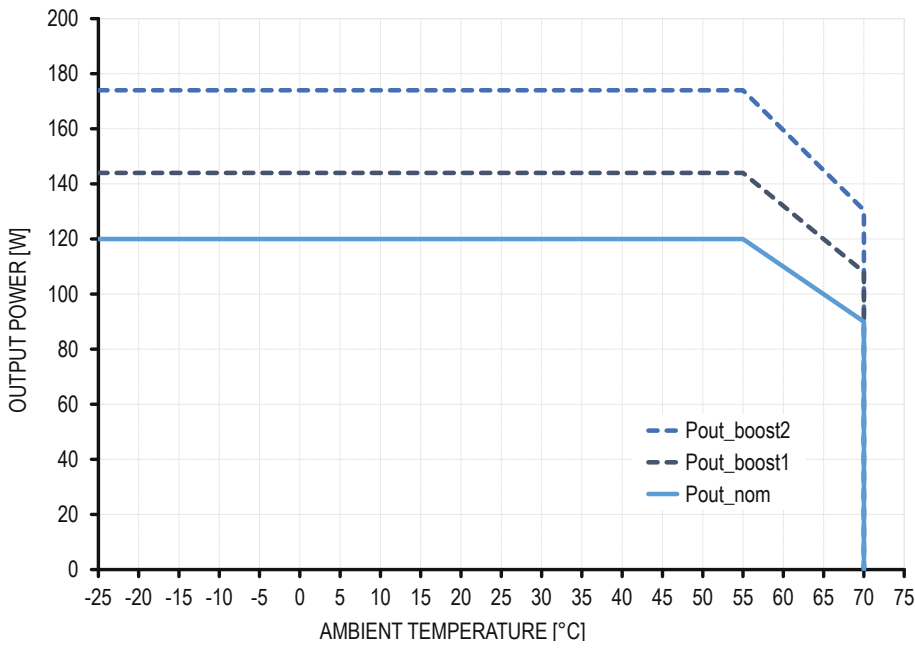

Fig. 19: Available output power as a function of the ambient temperature for normal mounting position

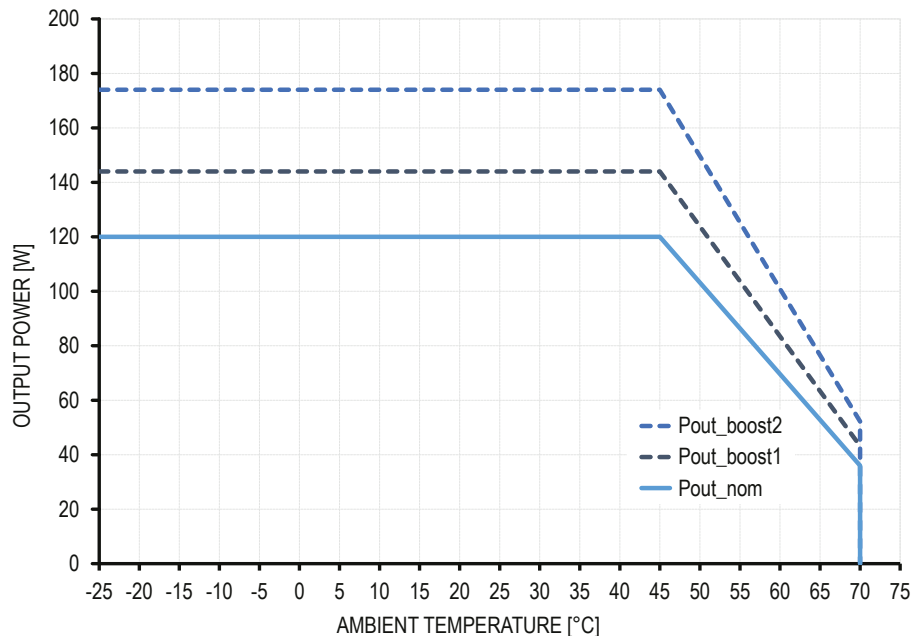
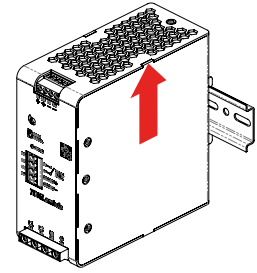
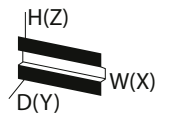
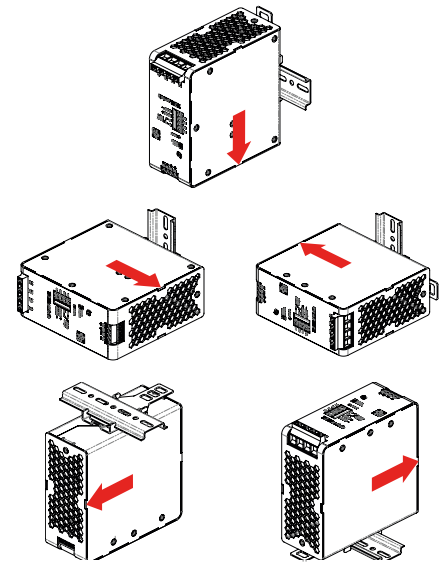

Fig. 20: Available output power as a function of the ambient temperature for rotated mounting positions



7. Reliability and Service lifetime

The service lifetime of the power supply is determined primarily by the electrolytic capacitors utilised. The values provided herein are calculated estimates, and as such, do not represent guaranteed lifetimes. The calculation is based on the respective capacitor manufacturer's method, taking into account ripple current, operating frequency, and capacitor temperature under the herein specified operating conditions. It is important to note that, due to the theoretical nature of the calculation, all capacitor manufacturers specify a maximum expected service lifetime of 15 years.

TDK-Lambda applies strict component selection criteria and utilises electrolytic capacitors exclusively from reputable manufacturers such as Nippon Chemi-Con, Nichicon, Rubycon, and TDK.

Service lifetime	<i>min.</i>	131 400 / 127 000hrs	400 / 500V _{AC} , 100% P _{out_nom} , 40°C _{amb} , 24/7
	<i>min.</i>	131 400 / 131 400hrs	400 / 500V _{AC} , 75% P _{out_nom} , 40°C _{amb} , 24/7
	<i>min.</i>	131 400 / 131 400hrs	400 / 500V _{AC} , 100% P _{out_nom} , 25°C _{amb} , 24/7
Early life MTBF	<i>min.</i>	1.1M / 1.0M / 0.8M hrs	25 / 40 / 55°C _{amb} , 50% P _{out_nom}
Telcordia SR-332 Issue 4	<i>min.</i>	0.79M / 0.65M / 0.55M hrs	25 / 40 / 55°C _{amb} , 100% P _{out_nom}
Service life MTBF	<i>min.</i>	5.7M / 4.0M / 2.2M hrs	25 / 40 / 55°C _{amb} , 50% P _{out_nom}
Telcordia SR-332 Issue 4	<i>min.</i>	1.8M / 1.4M / 0.9M hrs	25 / 40 / 55°C _{amb} , 100% P _{out_nom}

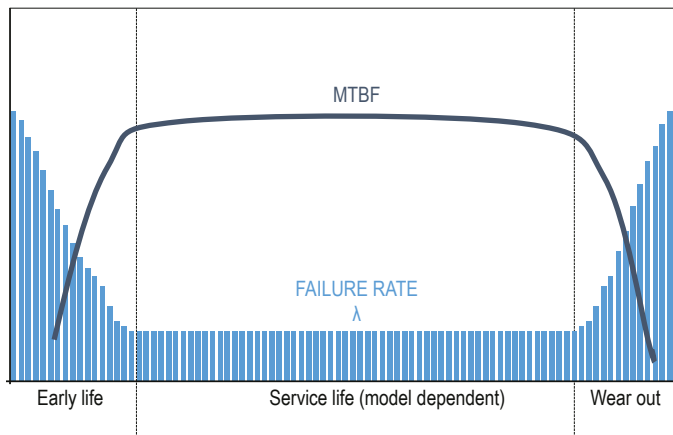

Fig. 21: General diagram illustrating the failure rate and MTBF values during the product life cycle

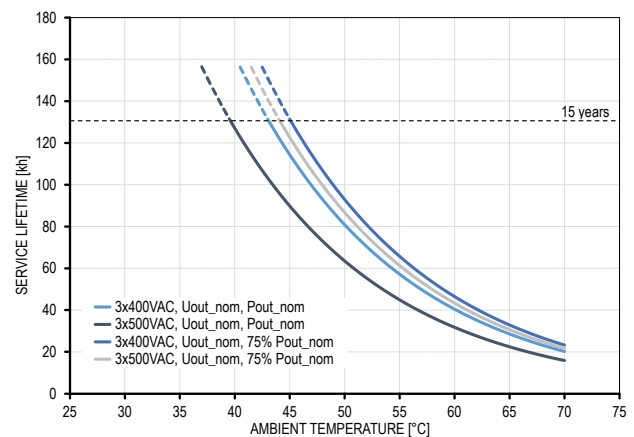

Fig. 22: Power supply service lifetime as a function of the ambient temperature

8. Dimensions & Mechanical data

Enclosure material	Aluminum	
Cover material	Aluminum	
Inflammability class	V0	incl. connection terminals
UL 94		
Width	55.0mm (2 ¹¹ / ₆₄ in)	
Height	129.0mm (5 ⁹ / ₆₄ in)	
Depth	w/o DIN rail	
Screw terminal models	135.7mm (5 ¹¹ / ₃₂ in)	
Push-in terminal models	138.2mm (5 ⁷ / ₁₆ in)	
Weight	660g (1.46lb)	
Lever arm	<i>max.</i>	62mm (2 ⁷ / ₁₆ in) into the direction of Y axis
Torsional moment on DIN rail	<i>max.</i>	0.4Nm (3.55lb in) into the direction of Z axis
Enclosure openings	<i>max.</i>	7mm (9/ ₃₂ in)
DIN rail types	TH 35-7.5, TH 35-15	
IEC 60715		

Unless otherwise stated, all values are specified in normal mounting position, at full load, nominal input and output voltages, 25°C (77°F) ambient temperature and a run-in time of 5 minutes.

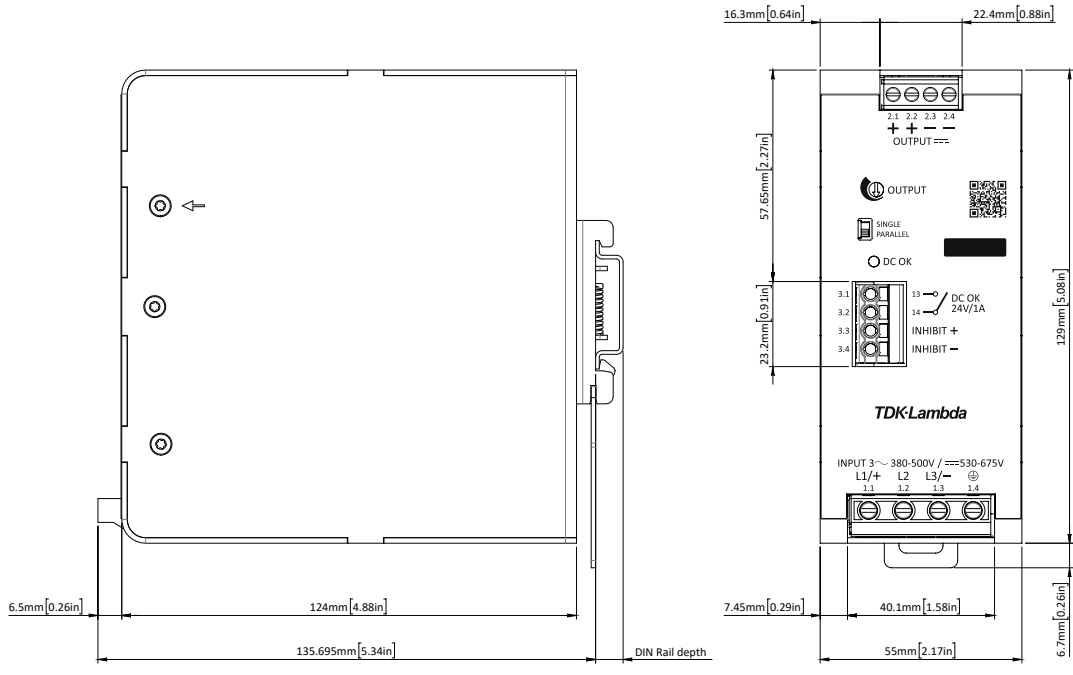

Fig. 23: Dimension drawing of DRB120-12-3-A0

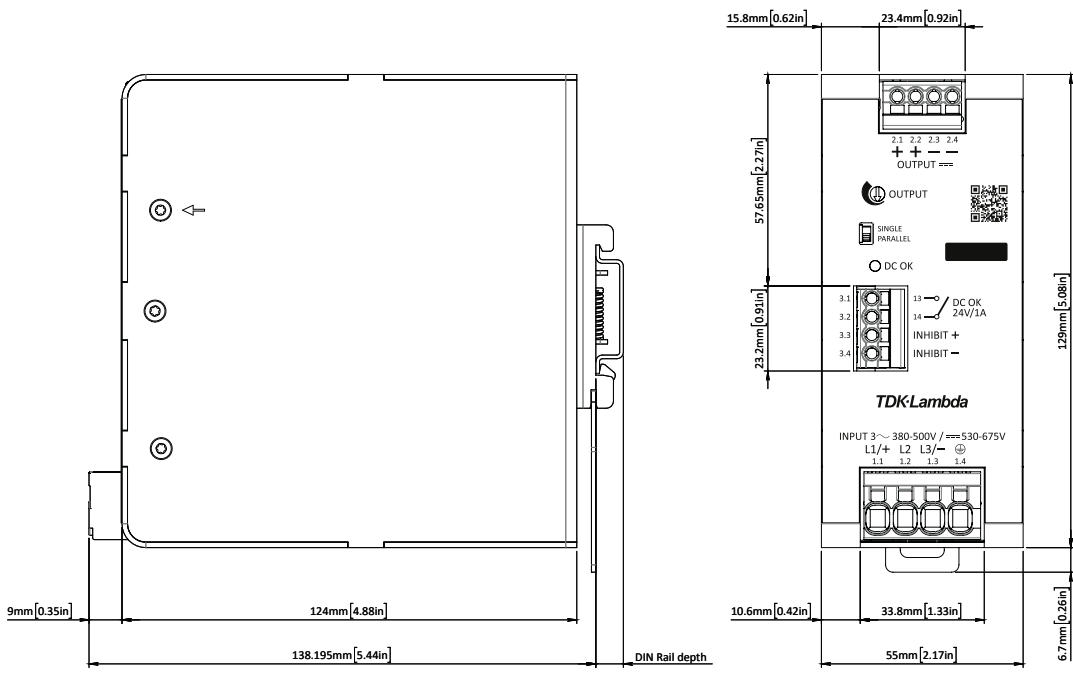

Fig. 24: Dimension drawing of DRB120-12-3-A1

Unless otherwise stated, all values are specified in normal mounting position, at full load, nominal input and output voltages, 25°C (77°F) ambient temperature and a run-in time of 5 minutes.

9. Installation clearances

Vertically (Z axis)

Top side	1	min.	40mm (1 ³⁷ / ₆₄ in)
Bottom side	2	min.	20mm (2 ⁵ / ₃₂ in)

installation above heat sources not permitted

Horizontally (X axis)

Left side / Right side	3a 4a	min.	5mm (1 ³ / ₆₄ in)
Left side / Right side	3b 4b	min.	2mm (5 ⁵ / ₆₄ in)

to heat sources (same power rating)
to passive components

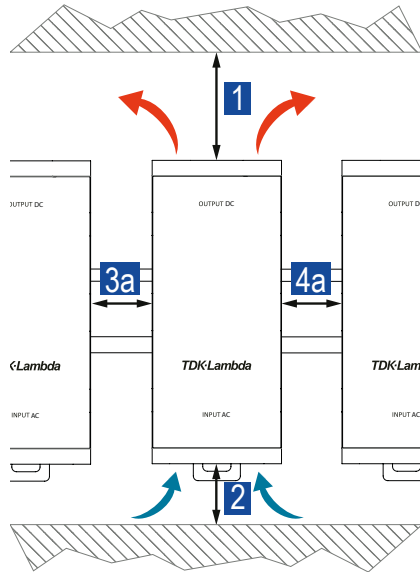

Fig. 25: Installation clearances to heat sources

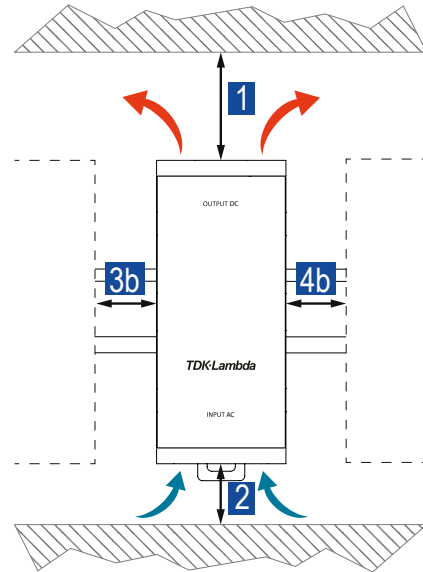

Fig. 26: Installation clearances to passive components

10. Wiring & Connection

DRB120-12-3-A0

Terminal type
Recommended screw driver

Solid wire

Flexible wire

Insulated ferrules*

Uninsulated ferrules*

Stripping length

Tightening torque

Input

Slotted screw

SL 0.8x4.0mm
(SL 1¹/₃₂ x 1¹/₈in)

0.5-4.0mm² (26-10AWG)

0.5-4.0mm² (26-10AWG)

0.25-2.5mm²

0.25-2.5mm²

6-7mm (1⁵/₆₄ - 9¹/₃₂in)

0.5-0.8Nm (4.4-7.0lb in)

Output

Slotted screw

SL 0.6x3.5mm
(SL 1¹/₃₂ x 9¹/₆₄in)

0.5-2.5mm² (24-12AWG)

0.5-2.5mm² (24-12AWG)

0.25-1.5mm²

0.25-1.5mm²

7-8mm (9¹/₃₂ - 5¹/₁₆in)

0.5Nm (4.4lb in)

Signaling

Push-in

SL 0.5x3.0mm
(SL 1¹/₆₄ x 1¹/₈in)

0.2-2.5mm² (26-12AWG)

0.2-2.5mm² (26-12AWG)

0.2-1.5mm²

0.2-2.5mm²

9-10mm (2³/₆₄ - 2⁵/₆₄in)

-

DRB120-12-3-A1

Terminal type
Recommended screw driver

Solid wire

Flexible wire

Insulated ferrules*

Uninsulated ferrules*

Stripping length

Push-in

SL 0.6x3.5mm
(SL 1¹/₃₂ x 9¹/₆₄in)

0.2-10.0mm² (24-8AWG)

0.2-6.0mm² (24-8AWG)

0.25-4.0mm²

0.25-6.0mm²

15mm (1⁹/₃₂in)

Push-in

SL 0.5x3.0mm
(SL 1¹/₆₄ x 1¹/₈in)

0.2-2.5mm² (26-12AWG)

0.2-2.5mm² (26-12AWG)

0.2-1.5mm²

0.2-2.5mm²

9-10mm (2³/₆₄ - 2⁵/₆₄in)

Push-in

SL 0.5x3.0mm
(SL 1¹/₆₄ x 1¹/₈in)

0.2-2.5mm² (26-12AWG)

0.2-2.5mm² (26-12AWG)

0.2-1.5mm²

0.2-2.5mm²

9-10mm (2³/₆₄ - 2⁵/₆₄in)

*The ferrules must be selected to match the stripping length.

i It is recommended that ferrules are used when working with flexible wires.

i In compliance with IEC 61010-1, 61010-2-201 appropriate copper wires must be used that withstand operating temperatures of at least 75°C (167°F) in ambients NOT exceeding 40°C (104°F), and 90°C (194°F) in ambients exceeding 40°C (104°F).

11. Signaling & Control

DC OK

Type		Relay contact	
Characteristic		N/O	
Closing		$U_{out} > 95\% U_{set}$	duration max. 300ms
Opening		$U_{out} < 50\% U_{set}$	duration max. 100ms
Resistive load	<i>nom.</i>	1A	24V _{DC}
	<i>max.</i>	0.5A	60V _{DC}
Trigger hysteresis	<i>typ.</i>	0.6V	

Remote ON/OFF

Type		Electrical contact	
Characteristic		Inhibit	
ON threshold	<i>max.</i>	3V	
OFF threshold	<i>min.</i>	4.5V	
Restart delay	<i>max.</i>	6s	
Operating voltage	<i>max.</i>	30V	
Operating current	<i>max.</i>	10mA	
Reference potential		Isolated	
Parallel connection		yes	
Active discharging		no	

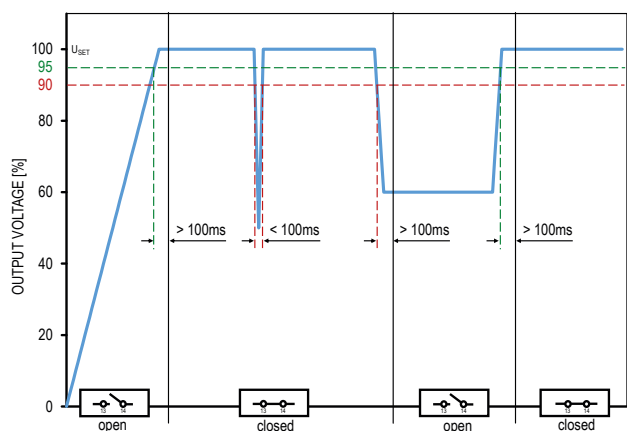

Fig. 27: DC-OK relay status as a function of output voltage changes

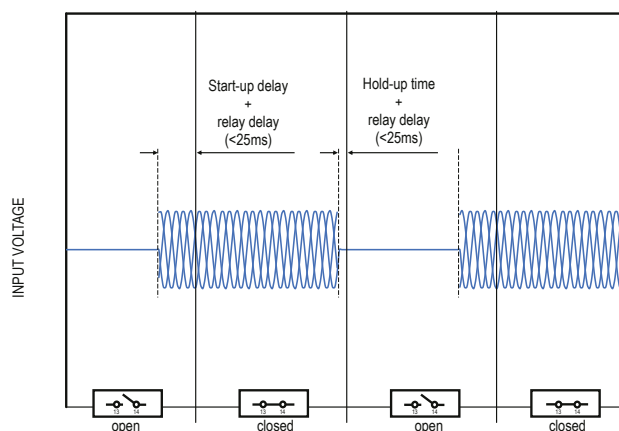

Fig. 28: DC-OK relay status as a function of AC mains connection

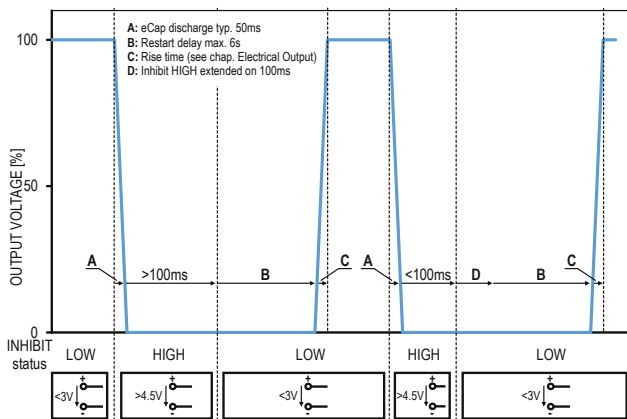

Fig. 29: Control of the output voltage as a function of the inhibit relay status.

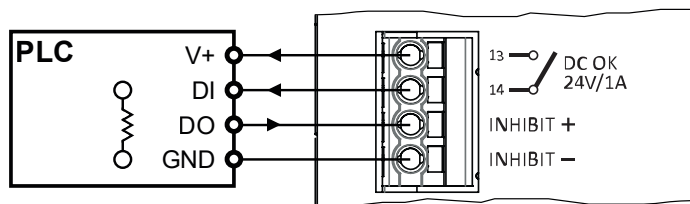
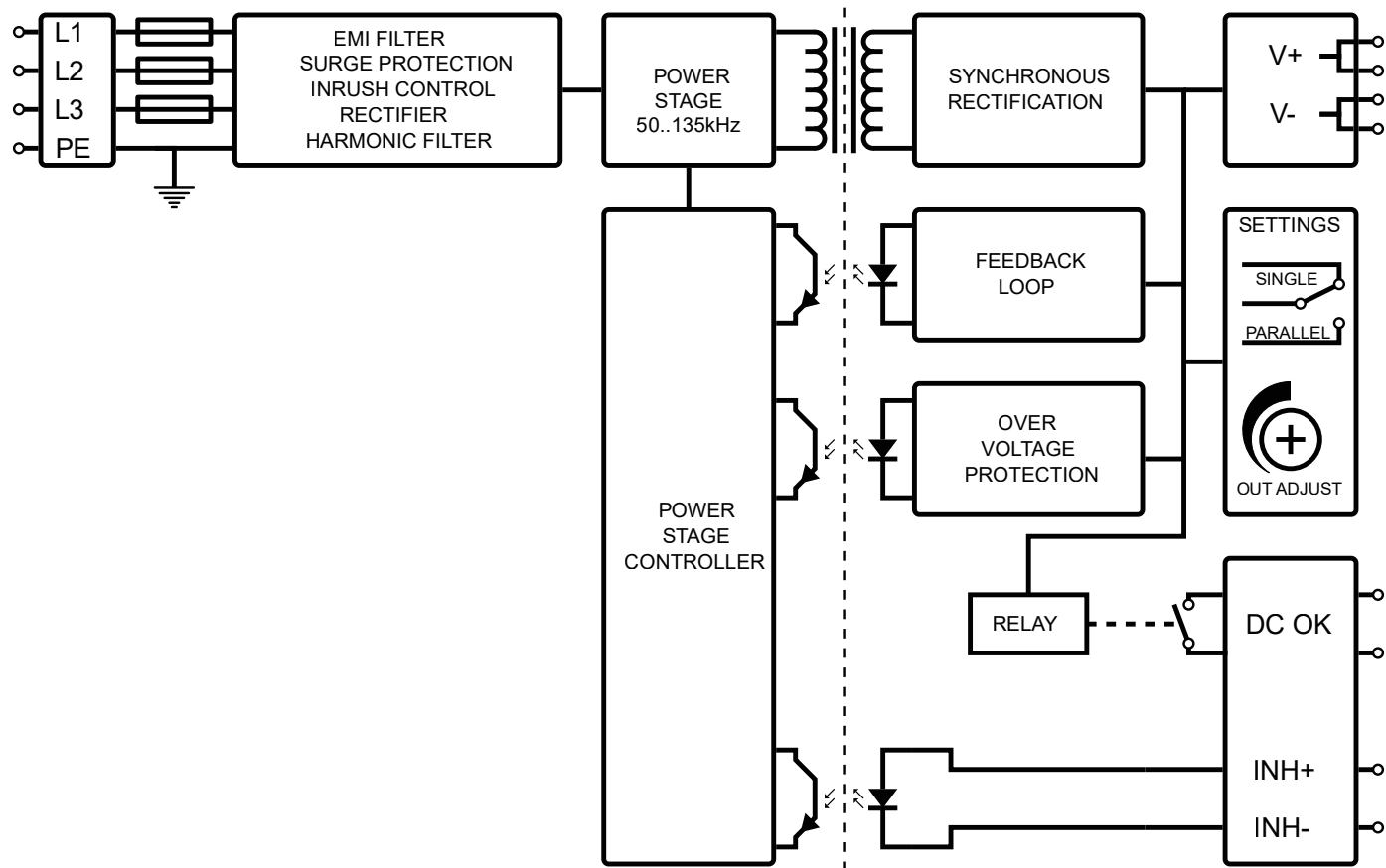

Fig. 30: Generic connection diagram of DC OK and INHIBIT contacts

12. Block diagram



i Switching frequencies are depending on U_{in} , U_{out} and I_{out} .

13. Device protection

Ingress protection degree IEC 60529	IP 20	
NEMA classification NEMA 250-2018	NEMA 1	
Overtemperature protection (OTP)	Yes, with auto-recovery	
Output overvoltage protection (OVP)	<i>max.</i>	18.4V _{DC} , with auto-recovery
Undervoltage protection (UVP)	<i>max.</i>	270V _{AC}
Output overcurrent protection (OCP)	<i>min.</i>	145%, with auto-recovery
Integrated input fuse	3x T3.15A at L pins	not DC capable, not user replaceable
Required DC fuse	4A	
Recommended MCB types IEC 60898-1, UL 1077	B or C characteristic, 6/8/10A	
Transient protection		
1st level	MOV (Metal Oxide Varistor)	
2nd level	GDT (Gas Discharge Tube)	

i When installed in an end-product, the maximum branch circuit rating must not exceed 20A (IEC 62368-1). If the upstream supply provides a higher ampacity than 20A, an external protection device is required.

14. Electrical Safety

Class of protection IEC 61140	I	PE connection required
Electrical energy source classification IEC 62368-1	ES1	
Safety Extra Low Voltage IEC 61010-2-201, IEC 60950-1	SELV	
Protective Extra Low Voltage IEC 60204-1	PELV	Output must be earthed in the end application
Protective ground resistance	<i>max.</i> 100mΩ	
Ground leakage current IEC 60990	<i>max.</i> 0.9mA <i>max.</i> 1.0mA	TN/TT mains, 3x575V _{AC} , 50Hz TN/TT mains, 3x575V _{AC} , 60Hz
Touch current IEC 60990	<i>max.</i> 40μA <i>max.</i> 50μA	TN/TT mains, 3x575V _{AC} , 50Hz TN/TT mains, 3x575V _{AC} , 60Hz
Overvoltage category IEC 61010-1, IEC 62368-1 (Ed.3)	II	<3000mASL (<9842ftASL)

14.1 Overvoltage category design

Underlying IEC standard	61010-1	62368-1 ¹⁾	60950-1	61558-2-16 ²⁾	62477-1	61204-7	60664-1
Mains transient voltage	II	II	II	III	III	III	III
Creepage & Clearance	III	II	III	II	III	III	III

¹⁾ Edition 3

²⁾ not applicable along with IEC 61204-7

14.2 Insulation strength

	Type test (60s) IEC 61010-1, UL 2231-2	Routine test (3s) IEC 61010-1	Field test (3s)
Input / Output	A	6400V _{DC}	5000V _{DC}
Input / PE	B	2210V _{AC}	2210V _{AC}
Input / DC OK	C	3510V _{DC}	3510V _{DC}
Input / INHIBIT	D	3510V _{DC}	3510V _{DC}
Output / PE	E	1390V _{AC}	1390V _{AC}
Output / DC OK	F	1390V _{AC}	1390V _{AC}
Output / INHIBIT	G	1390V _{AC}	1390V _{AC}
DC OK / INHIBIT	H	1390V _{AC}	1390V _{AC}

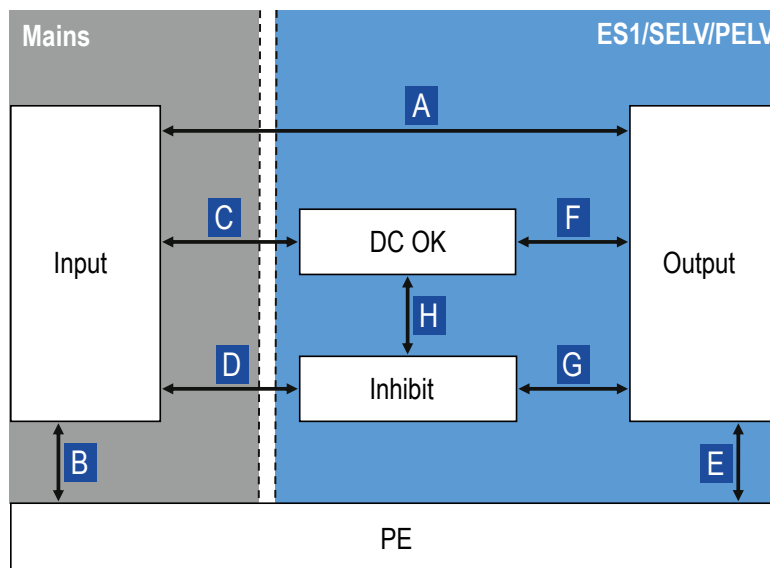

Fig. 31: Schematic of the insulation paths

14.3 HIPOT test

Apart from routine and type test, the end user might need to check the insulation strength during the final inspection and testing to guarantee the electrical safety of the end application. Therefore, a high-voltage test (HIPOT test) can be performed in the field. The following conditions must be observed:

- ▶ As every HIPOT test causes stress on the power supplies safety insulation, avoid frequent HIPOT testing or excessive test voltages
- ▶ The test voltages and durations, as indicated under „14.2 Insulation strength“ on page 19, must not be exceeded
- ▶ The test voltages rise and fall time should be between 2 and 4 seconds
- ▶ For the HIPOT test of the insulation path (B) between Input and PE, the gas discharge tube (GDT) must be disconnected

Disconnection of the GDT:

- 1) Completely remove the connection screw (marked with an arrow) with a Torx X10. (Fig. 32)
- 2) Keep the screw in a safe place.
- 3) After completion of testing, reconnect the GDT only with the original screw to avoid risk of electrical shock or damage.
- 4) Fasten the screw with a Torx X10 not exceeding a tightening torque of 0.7 Nm.

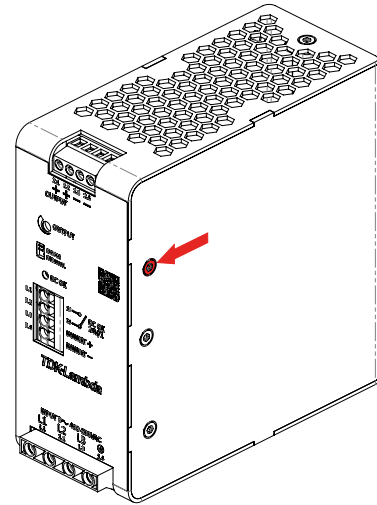

Fig. 32: Position of the connection screw for the GDT

i According to EN 60204-1 (Safety of machinery - Electrical equipment of machines), an individual HIPOT test of the power supply isn't required. During the HIPOT test of the end application, the power supply can be disconnected and only installed once the test has been completed.

15. Electromagnetic immunity

Investigated under generic standards IEC EN 61000-6-2 (2019) - Immunity for industrial environments.

Electrostatic contact discharge IEC EN 61000-4-2	4kV	Criterion A	330Ω / 150pF
Electrostatic air discharge IEC EN 61000-4-2	8kV	Criterion A	330Ω / 150pF
Electromagnetic RF field¹⁾ IEC EN 61000-4-3	10V/m 3V/m 1V/m	Criterion A Criterion A Criterion A	80MHz..1GHz 1.4GHz..2GHz 2GHz..2.7GHz
Fast transients (burst) IEC EN 61000-4-4			
Input ²⁾	4kV	Criterion A	5kHz
Output	2kV	Criterion A	5kHz
Signal contact ²⁾	2kV	Criterion A	5kHz
Surge voltages IEC EN 61000-4-5			
Input symmetrical (L-L) ²⁾	2kV	Criterion A	2Ω+18μF, for Φ = 0°,90°,180°,270°
Input asymmetrical (L-PE) ²⁾	4kV	Criterion A	12Ω+9μF, for Φ = 0°,90°,180°,270°
Output symmetrical (L-L)	0.5kV	Criterion A	2Ω+18μF
Output asymmetrical (L-PE)	1kV	Criterion A	12Ω+9μF
Signal line asymmetrical (Signal-PE)	1kV	Criterion A	42Ω+0.5μF
Conducted disturbances IEC EN 61000-4-6			
Input, signal line, PE ³⁾	10V	Criterion A	150kHz..80MHz
Power frequency magnetic field IEC EN 61000-4-8	30A/m	Criterion A	50Hz, 60s each axis (x, y, z)
Voltage dips/sags and interruptions IEC EN 61000-4-11, 61000-4-34	500ms 200ms 20ms 5000ms	Criterion A Criterion A Criterion A Criterion C	400V _{AC} at 70%, 50Hz 400V _{AC} at 40%, 50Hz 400V _{AC} at 0%, 50Hz 400V _{AC} at 0%, 50Hz
SEMI F47-0706	1000ms 500ms 200ms 20ms	Criterion A Criterion A Criterion A Criterion A	400V _{AC} at 80%, 50Hz 400V _{AC} at 70%, 50Hz 400V _{AC} at 50%, 50Hz 400V _{AC} at 0%, 50Hz

¹⁾ Except for the ITU broadcast frequency bands 87..107MHz, 174..230MHz and 470..790MHz, where the level shall be 3V/m.

²⁾ Exceeds the requirements of the European Low Voltage Directive 2014/35/EU

³⁾ Except for the ITU broadcast frequency bands 47..68MHz, where the level shall be 3V.

Performance level definitions:

Criterion A:

The device continues operation as intended during and after the test. The specified performance level accepts a change of ±10% on nominal output voltage and current. There is neither a violation of the performance level, nor a loss of function if the device is used as intended.

Criterion B:

The device continues operation as intended after the test. The specified performance level accepts a change of ±10% on nominal output voltage and current. There is neither a violation of the performance level, nor a loss of function if the device is used as intended. During the test a violation of the performance level is allowed.

Criterion C:

A temporary loss of function is allowed, provided the function is auto-recoverable, or can be restored by the operation of the controls.



16. Electromagnetic emission

Investigated under generic standards IEC EN 61000-6-3 (2007) + A1 (2011) / AC (2012) - Emission standard for residential, commercial and light-industrial environments.

Conducted noise emission input EN 55011, CISPR 11	Class B	150kHz..30MHz
Radiated noise emission input EN 55011, CISPR 11	Class B	30MHz..1GHz
Harmonic currents input IEC EN 61000-3-2	Class A	0kHz..2kHz
Total harmonic distortion (THD) input IEC EN 61000-3-2	155% per phase	Order 1..40
Voltage changes, voltage fluctuations and flicker input IEC EN 61000-3-3	PASS	50Hz

Unless otherwise stated, all values are specified in normal mounting position, at full load, nominal input and output voltages, 25°C (77°F) ambient temperature and a run-in time of 5 minutes.

17. Certifications & Approvals





	UL 61010-1 CAN/CSA-C22.2 No. 61010-1	Safety requirements for electrical equipment for measurement, control, and laboratory use - Part 1: General requirements
	UL 61010-2-201 CAN/CSA-C22.2 No. 61010-2-201	Safety requirements for electrical equipment for measurement, control, and laboratory use - Part 2-201: Particular requirements for control equipment UL file: E356563
	IEC EN 61010-1	Safety requirements for electrical equipment for measurement, control, and laboratory use - Part 1: General requirements
	IEC EN 61010-2-201	Safety requirements for electrical equipment for measurement, control, and laboratory use - Part 2-201: Particular requirements for control equipment
	IEC EN 62368-1 (Ed.3)	Audio/video, information and communication technology equipment - Part 1: Safety requirements
	UL 62368-1 (Ed.3)	Audio/video, information and communication technology equipment - Part 1: Safety requirements UL file: E511889

18. Designed to meet

The safety design of the product complies additionally with the following standards.

IEC 60950-1	Information technology equipment - Safety - Part 1: General requirements
IEC EN 62477-1	Safety requirements for power electronic converter systems and equipment - Part 1: General
IEC EN 61204-3	Low-voltage switch mode power supplies - Part 3: Electromagnetic compatibility
IEC EN 61204-7	Low-voltage switch mode power supplies - Part 7: Safety requirements
IEC EN 61558-2-16	Safety of transformers, reactors, power supply units and similar products for supply voltages up to 1100 V - Part 2-16: Particular requirements and tests for switch mode power supply units and transformers for switch mode power supply units
EN 60204-1	Safety of machinery - Electrical equipment of machines - Part 1: General requirements
IEC EN 60068-2-60	Environmental testing - Part 2-60: Test Ke: Flowing mixed gas corrosion test
IEC 60068-2-11	Environmental testing - Part 2-11: Test Ka: Salt mist
UL 508	Industrial Control Equipment

19. Compliance & Registration

	Conformity with health, safety, and environmental protection standards for products sold within the European Economic Area (EEA).
	UKCA (UK Conformity Assessed) is the product marking that is used for certain goods being placed on the United Kingdom market.
	The Waste Electrical and Electronic Equipment Directive (WEEE Directive) is the European Community Directive 2012/19/EU on collection, recycling and recovery targets for all types of electrical goods.
	The Restriction of Hazardous Substances Directive 2011/65/EU (RoHS 2) regulates the use of certain hazardous substances in electrical and electronic equipment.
	Registration, Evaluation, Authorisation and Restriction of Chemicals (REACH) is a European Union regulation that addresses the production and use of chemical substances, and their potential impacts on both human health and the environment.

Unless otherwise stated, all values are specified in normal mounting position, at full load, nominal input and output voltages, 25°C (77°F) ambient temperature and a run-in time of 5 minutes.

20. Application notes

20.1 Parallel Operation

In order to increase the output power it is possible to connect the power supplies in parallel. Furthermore, a paralleling can be done for limited redundancy purposes in order to backup malfunctions occurring on the primary side of the power supplies. The following measures must be taken into account:

- ▶ Only power supplies of the same series and power rating must be paralleled
- ▶ The dip switch on the front side of the power supplies must be switched to PARALLEL
- ▶ Load wiring shall be identical in terms of length and cross section
- ▶ The output voltage of the power supplies shall be adjusted to the same value ($\pm 100\text{mV}$)
- ▶ All paralleled power supplies must be operated under the same ambient conditions
- ▶ The power supplies must not be operated under any condition which requires a power derating (e.g. altitudes above 3000mASL (9842ftASL), temperatures above $55^\circ\text{C}_{\text{amb}}$ ($131^\circ\text{F}_{\text{amb}}$), mounting orientations others than the normal mounting position, etc.)
- ▶ If more than three power supplies are paralleled, each output must be protected by a decoupling module (e.g. TDK-Lambda DRM series), MCB, diode, or fuse
- ▶ The increased installation clearances must be considered (see „9. Installation clearances“ on page 16)

i In parallel operations the values of output load regulation, inrush currents, EMI, harmonic and leakage currents will increase.

i When changing the operating mode between SINGLE and PARALLEL, the mains voltage must be disconnected.

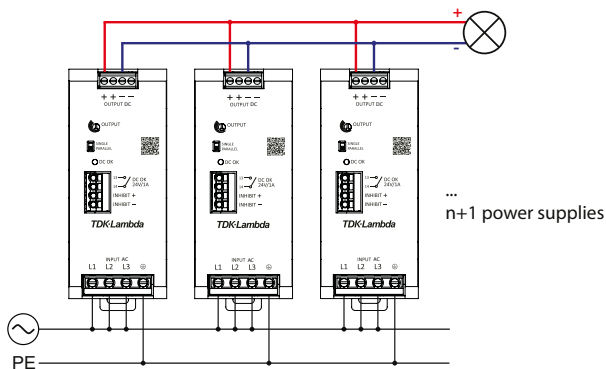

Fig. 33: Connection scheme of n+1 power supplies paralleled for the purpose of power increase

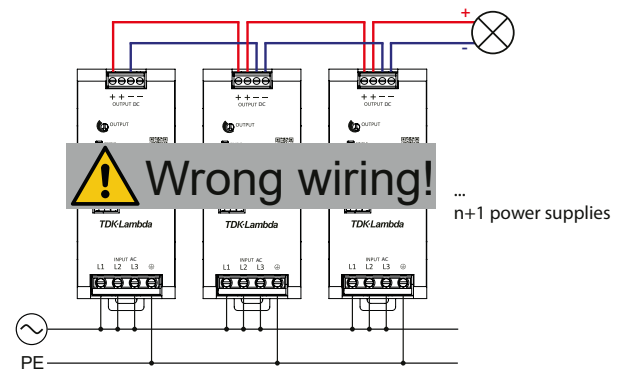

Fig. 34: Example of a wrong connection scheme

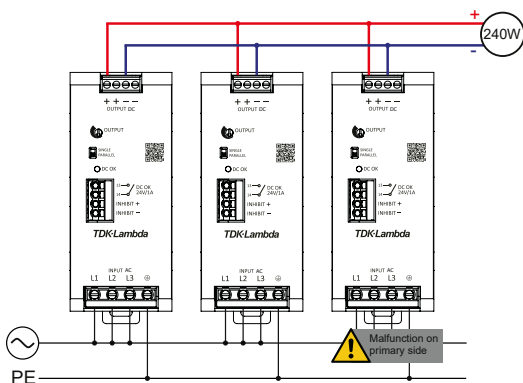

Fig. 35: Connection scheme of n+1 power supplies paralleled for the purpose of a 240W limited redundancy

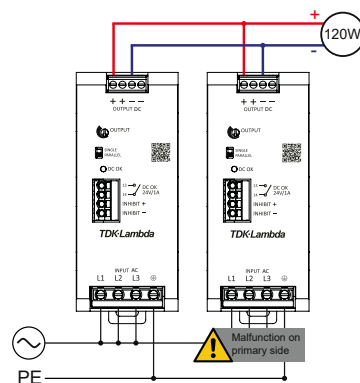

Fig. 36: Connection scheme of 1+1 power supplies paralleled for the purpose of a 120W limited redundancy

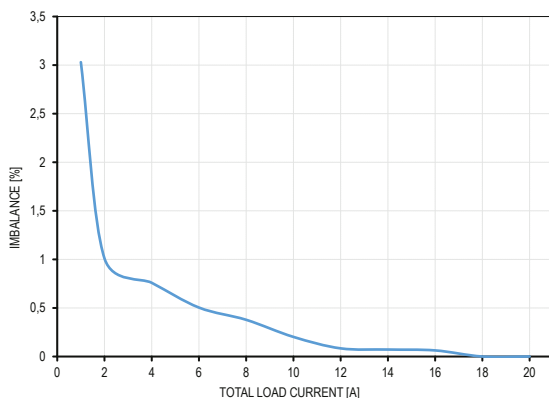



Fig. 37: Typical load sharing behaviour of two power supplies in parallel mode

Unless otherwise stated, all values are specified in normal mounting position, at full load, nominal input and output voltages, 25°C (77°F) ambient temperature and a run-in time of 5 minutes.

20.2 Series operation

In order to increase the output voltage, it is possible to connect the power supplies in series. The following measures must be taken into account:

- ▶ The output voltage sum must not exceed 250V_{DC}
- ▶ If the output voltage sum exceeds 60V_{DC}, a safeguard against unintended touching must be considered
- ▶ Only power supplies of the same series and power rating must be connected in series
- ▶ The dip switch on the front side of the power supplies must be switched to SINGLE
- ▶ All power supplies in series must be operated under the same ambient conditions
- ▶ The power supplies must not be operated under any condition which requires a power derating (e.g. altitudes above 3000mASL (9842ftASL), temperatures above 55°C_{amb} (131°F_{amb}), mounting orientations others than the normal mounting position, etc.)
- ▶ The increased installation clearances must be considered (see „9. Installation clearances“)

 In series operations the values of output load regulation, inrush currents, EMI, harmonic and leakage currents will increase.

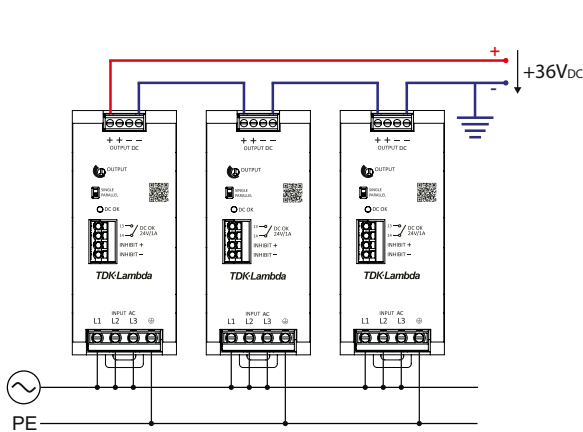

Fig. 38: Connection scheme for series operation with positive voltage level

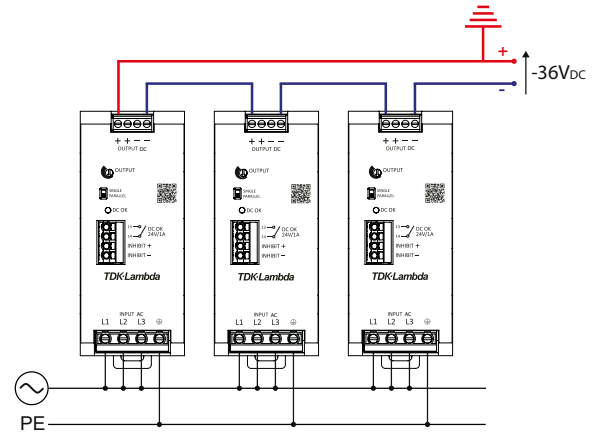

Fig. 39: Connection scheme for series operation with negative voltage level

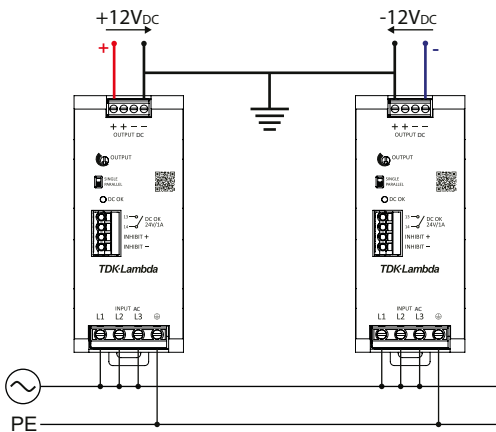

Fig. 40: Connection scheme for series operation with centre tap

20.3 Two-phase operation

The device is capable to run continuously on two phases of a 3-phase power grid. A power derating under nominal conditions is not required. All conditions associated with a power derating must be carefully considered.

Please note if running on two phases:

- ▶ Power losses will increase and can no longer be guaranteed as specified for 3-phase operation
- ▶ Hold-up times as specified for 3-phase operation can no longer be guaranteed
- ▶ The device will go into OTP mode if operating permanently at input voltages below 342V_{AC}
- ▶ The device is no more compliant with IEC EN 61000-3-2 harmonic current limits
- ▶ Safety approvals under UL 61010-1, -2-201 and UL 62368-1 (Ed.3) are no more applicable

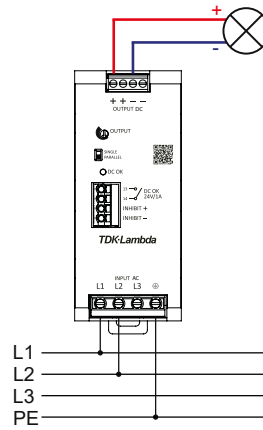

Fig. 41: Connection diagram for 2-phase operation



TDK-Lambda France SAS

Tel: +33 1 60 12 71 65
tlf.fr-powersolutions@tdk.com
www.emea.lambda.tdk.com/fr



TDK-Lambda Americas

Tel: +1 800-LAMBDA-4 or 1-800-526-2324
tla.powersolutions@tdk.com
www.us.lambda.tdk.com



Italy Sales Office

Tel +39 02 61 29 38 63
tlf.it-powersolutions@tdk.com
www.emea.lambda.tdk.com/it



TDK Electronics do Brasil Ltda

Tel: +55 11 3289-9599
sales.br@tdk-electronics.tdk.com
www.tdk-electronics.tdk.com/en



Netherlands

tlf.nl-powersolutions@tdk.com
www.emea.lambda.tdk.com/nl



TDK-Lambda Corporation

Tel: +81-3-6778-1113
www.jp.lambda.tdk.com



TDK-Lambda Europe GmbH

Tel: +49 7841 666 0
tig.powersolutions@tdk.com
www.emea.lambda.tdk.com/de



TDK-Lambda (China) Electronics Co. Ltd.

Tel: +86 21 6485-0777
tlc.powersolutions@tdk.com
www.lambda.tdk.com.cn



Austria Sales Office

Tel: +43 2256 655 84
tig.at-powersolutions@tdk.com
www.emea.lambda.tdk.com/at



TDK-Lambda Singapore Pte Ltd.

Tel: +65 6251 7211
tfs.marketing@tdk.com
www.sg.lambda.tdk.com



Switzerland Sales Office

Tel: +41 44 850 53 53
tig.ch-powersolutions@tdk.com
www.emea.lambda.tdk.com/ch



TDK India Private Limited, Power Supply Division

Tel: +91 80 4039-0660
mathew.philip@tdk.com
www.sg.lambda.tdk.com



TDK-Lambda Europe GmbH

Tel: Tel. +45 3222 8086
tig.dk-powersolutions@tdk.com
www.emea.lambda.tdk.com/dk



TDK-Lambda UK Ltd.

Tel: +44 (0) 12 71 85 66 66
tlu.powersolutions@tdk.com
www.emea.lambda.tdk.com/uk



TDK-Lambda Ltd.

Tel: +9 723 902 4333
tli.powersolutions@tdk.com
www.emea.lambda.tdk.com/il-en

For further information please visit:
emea.lambda.tdk.com/dr3-3-phase

