

# 1100 - 2100 WATT MBH SERIES DC/DC CONVERTERS

**PRELIMINARY**



## Features

- Delivers up to 2100 Watts
- Efficiency up to 97%
- Groundbreaking low profile compact 9.0"L x 6.5"W x 1.25"H package
- Only 3.3 lbs
- No minimum load required
- Fixed frequency operation at 400 kHz
- Fully protected (OTP, OCP, OVP, UVLO)
- Auto Recovery
- Input reverse polarity protection
- High Reliability
- Made in USA
- 5 Year Warranty

## Description

The Calnex 2100 Watt MBH DC/DC Converter series are high efficiency non-isolated dc/dc switched-mode single output converters specifically designed for both military and commercial mobile applications. This series is packaged in an unprecedented low profile 9.0"L x 6.5"W x 1.25"H mechanically enclosed package weighing only 3.3lbs making the unit ideal for harsh shock and vibration environments. The MBH series integrates high efficiency dc/dc converters with input transient and reverse polarity protection circuitry. The DC/DC Converters are designed with a wide operational temperature range and are well suited for a high temperature environment.

The MBH Series DC/DC converter's high efficiency and high power density are accomplished through the use of high-efficiency synchronous rectification technology, advanced electronic circuitry, packaging and thermal design resulting in highly reliable product. The MBH series operates at a fixed switching frequency and follows conservative component de-rating guidelines. The converter is designed and manufactured in the USA and is backed by Calnex's 5 year warranty.

Model	Input Range VDC		Vout VDC	Iout ADC
	Min	Max		
13S28.40MBH	10	16	28	40
13S28.60MBH	10	16	28	60
13S28.75MBH	10	16	28	75
28S12.100MBH	23	32	12	100
28s13.100MBH	23	32	13.5	100

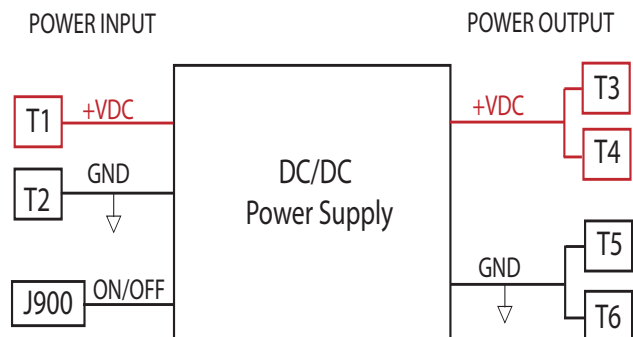

# 1100 - 2100 WATT MBH SERIES DC/DC CONVERTERS

**PRELIMINARY**



The MBH Converters have two input power M8 bushings T1 - T2, and a signal connector for ON/OFF control (Fig. 2), and two pairs of output power M8 bushings T3 - T6 (Fig.3). The converters are enabled by connecting the ON/OFF pin externally as well.

The DC/DC Converters are disabled when the ON/OFF pin is shorted to GND pin of J900, connected to GND externally or left open. The DC/DC Converters will automatically recover from over-temperature, over-current, short-circuit, over-voltage and input under-voltage conditions without recycling the ON/OFF control or input power.

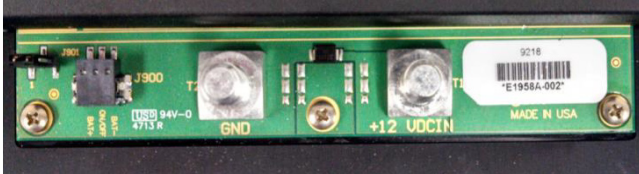

Figure 2. Input terminals and ON/OFF connector J900

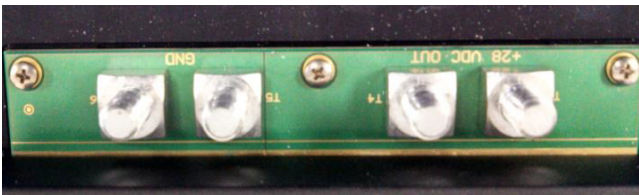

Figure 3. Output Terminals

# 1100 - 2100 WATT MBH SERIES DC/DC CONVERTERS

**PRELIMINARY**



<b>13S28.40MBH Specifications</b>					
Conditions: $T_A=25^{\circ}\text{C}$ , $V_{IN} = 12\text{VDC}$ , unless otherwise noted; not required to operate below 10V.					
Input Parameter	Conditions	Min	Typ	Max	Units
<b>Absolute Maximum Ratings</b>					
Input Voltage					VDC
Non-Operating	Protected from reverse polarity on the input terminals	-20		30	VDC
Operating		10		16	VDC
Voltage at ON/OFF input pin		0		30	VDC
<b>Input Characteristics</b>					
Operating Input Voltage Range		10	13.2	16	VDC
Maximum Input Current	$P_O = 1100\text{W} @ 10\text{VDC in}$		115	118	A
Start-up Voltage	$V_{IN}$		9.5		VDC
Shut Down Voltage	$V_{IN}$		9.0		VDC
Input Stand-by Current	$V_{IN} = 12\text{V}$ , converter disabled		1.25	3	mA
Input No load Current	$V_{IN} = 12\text{V}$ , converter enabled		1.25	1.5	A

Output Parameter	Conditions	Min	Typ	Max	Units
<b>Output Characteristics</b>					
Output Voltage Set Point	$V_{IN} = 12\text{V}$ , $I_O = 30.5\text{A}$	28.0	28.5	30.0	VDC
Output Regulation Over Line and Load			$\pm 80$	$\pm 120$	mV
Total Output Voltage Range	Over sample, line, load, temperature & life	27.6		29.3	VDC
Output Voltage Ripple and Noise Peak to Peak RMS	20MHz Bandwidth, 10 $\mu\text{F}$ tantalum + 1 $\mu\text{F}$ ceramic Full Load Resistive Full Load Resistive	300 60		500 100	mV <sub>P-P</sub> mV <sub>RMS</sub>
Operating Output Current Range		0		40	A
Output DC Current Limit Inception	Non-Latching	44	48	56	A
Output DC Current Limit Shutdown	Output Voltage at which converter shuts down		22		VDC
Peak Short-Circuit Current	Non-Latching, Startup into 10mR		75		ADC
Peak Short-Circuit Pulse Duration	Non-Latching, Startup into Short		16		ms
RMS Short-Circuit Current	Non-Latching, Startup into Short		TBD		A <sub>RMS</sub>
Dynamic Response					
Load Change 20A - 36A - 20A	$V_S=12\text{V}$ , $D_i/D_t=0.1\text{ A}/\mu\text{s}$ , 6ft. input cable AWG 1/0, 6 ft load cable		$\pm 1.9$		VDC
Load Change 20A - 36A - 20A	$V_S=12\text{V}$ , $D_i/D_t=0.1\text{ A}/\mu\text{s}$ , 20ft. input cable AWG 1/0, 6 ft load cable		$\pm 2.3$		VDC
Load Change 20A - 36A - 20A	$V_S=13.2\text{V}$ , $D_i/D_t=0.1\text{ A}/\mu\text{s}$ , 6ft. input cable AWG 1/0, 6 ft load cable		$\pm 2$		VDC
	* See Note 2 below for definition of $V_S$				
Setting Time	To within 1% $V_{out\ nom}$		500	1000	$\mu\text{s}$
Output Over-Voltage Protection	Non-Latching	32.7	34.8	37	VDC
Efficiency 100% Load 50% Load			96 96.55		% %

Note 1: Input and output voltages are measured at input and output terminals of the converter

Note 2:  $V_S$  - voltage at external power supply used for testing.  $V_{IN} < V_S$  due to voltage drop in input cable.

Note 3: All protections are non-latching. Once protection (OVP, OCP, input UVLO) are tripped converter enters into auto restart mode with 500 ms off time.



# 1100 - 2100 WATT MBH SERIES DC/DC CONVERTERS

**PRELIMINARY**



<b>13S28.60MBH Specifications</b>					
Conditions: $T_A=25^{\circ}\text{C}$ , $V_{IN} = 12\text{VDC}$ , unless otherwise noted; not required to operate below 10V.					
Input Parameter	Conditions	Min	Typ	Max	Units
<b>Absolute Maximum Ratings</b>					
Input Voltage					VDC
Non-Operating	Protected from reverse polarity on the input terminals	-20		30	VDC
Operating		10		16	VDC
Voltage at ON/OFF input pin		0		30	VDC
<b>Input Characteristics</b>					
Operating Input Voltage Range		10	13.2	16	VDC
Maximum Input Current	$P_O = 1700\text{W} @ 10\text{VDC in}$		176	180	A
Start-up Voltage	$V_{IN}$		9.5		VDC
Shut Down Voltage	$V_{IN}$		9.0		VDC
Input Stand-by Current	$V_{IN} = 12\text{V}$ , converter disabled		1.25	3	mA
Input No load Current	$V_{IN} = 12\text{V}$ , converter enabled		1.25	1.5	A

Output Parameter	Conditions	Min	Typ	Max	Units
<b>Output Characteristics</b>					
Output Voltage Set Point	$V_{IN} = 12\text{V}$ , $I_O = 30.5\text{A}$	28.0	28.5	30.0	VDC
Output Regulation Over Line and Load			$\pm 80$	$\pm 120$	mV
Total Output Voltage Range	Over sample, line, load, temperature & life	27.6		29.3	VDC
Output Voltage Ripple and Noise Peak to Peak RMS	20MHz Bandwidth, 10 $\mu\text{F}$ tantalum + 1 $\mu\text{F}$ ceramic Full Load Resistive Full Load Resistive	300 60		500 100	mV <sub>P-P</sub> mV <sub>RMS</sub>
Operating Output Current Range		0		60	A
Output DC Current Limit Inception	Non-Latching	66	72	84	A
Output DC Current Limit Shutdown	Output Voltage at which converter shuts down		22		VDC
Peak Short-Circuit Current	Non-Latching, Startup into 10mR		112		ADC
Peak Short-Circuit Pulse Duration	Non-Latching, Startup into Short		16		ms
RMS Short-Circuit Current	Non-Latching, Startup into Short		TBD		A <sub>RMS</sub>
<b>Dynamic Response</b>					
Load Change 30A - 54A - 30A	$V_S=12\text{V}$ , $D_i/D_t=0.1\text{ A}/\mu\text{s}$ , 6ft. input cable AWG 1/0, 6 ft load cable		$\pm 1.9$		VDC
Load Change 30A - 54A - 30A	$V_S=12\text{V}$ , $D_i/D_t=0.1\text{ A}/\mu\text{s}$ , 20ft. input cable AWG 1/0, 6 ft load cable		$\pm 2.3$		VDC
Load Change 30A - 54A - 30A	$V_S=13.2\text{V}$ , $D_i/D_t=0.1\text{ A}/\mu\text{s}$ , 6ft. input cable AWG 1/0, 6 ft load cable		$\pm 2$		VDC
	* See Note 2 below for definition of $V_S$				
Setting Time	To within 1% $V_{out\ nom}$		500	1000	$\mu\text{s}$
Output Over-Voltage Protection	Non-Latching	32.7	34.8	37	VDC
Efficiency 100% Load 50% Load			96.5 97.0		% %

Note 1: Input and output voltages are measured at input and output terminals of the converter

Note 2:  $V_S$  - voltage at external power supply used for testing.  $V_{IN} < V_S$  due to voltage drop in input cable.

Note 3: All protections are non-latching. Once protection (OVP, OCP, input UVLO) are tripped converter enters into auto restart mode with 500 ms off time.



# 1100 - 2100 WATT MBH SERIES DC/DC CONVERTERS

**PRELIMINARY**



## 13S28.75MBH Specifications

Conditions:  $T_A=25^{\circ}\text{C}$ ,  $V_{IN} = 12\text{VDC}$ , unless otherwise noted; not required to operate below 10V.

Input Parameter	Conditions	Min	Typ	Max	Units
<b>Absolute Maximum Ratings</b>					
Input Voltage					VDC
Non-Operating	Protected from reverse polarity on the input terminals	-20		30	VDC
Operating		10		16	VDC
Voltage at ON/OFF input pin		0		30	VDC
<b>Input Characteristics</b>					
Operating Input Voltage Range		10	13.2	16	VDC
Maximum Input Current	$P_O = 2100\text{W} @ 10\text{VDC}$ in		223	227	A
Start-up Voltage	$V_{IN}$		9.5		VDC
Shut Down Voltage	$V_{IN}$		9.0		VDC
Input Stand-by Current	$V_{IN} = 12\text{V}$ , converter disabled		1.25	3	mA
Input No load Current	$V_{IN} = 12\text{V}$ , converter enabled		1.25	1.5	A

Output Parameter	Conditions	Min	Typ	Max	Units
<b>Output Characteristics</b>					
Output Voltage Set Point	$V_{IN} = 12\text{V}$ , $I_O = 30.5\text{A}$	28.0	28.5	30.0	VDC
Output Regulation Over Line and Load			$\pm 80$	$\pm 120$	mV
Total Output Voltage Range	Over sample, line, load, temperature & life	27.6		29.3	VDC
Output Voltage Ripple and Noise Peak to Peak RMS	20MHz Bandwidth, 10 $\mu\text{F}$ tantalum + 1 $\mu\text{F}$ ceramic Full Load Resistive Full Load Resistive	300 60		500 100	mV P-P mV RMS
Operating Output Current Range		0		75	A
Output DC Current Limit Inception	Non-Latching	83	90	105	A
Output DC Current Limit Shutdown	Output Voltage at which converter shuts down		22		VDC
Peak Short-Circuit Current	Non-Latching, Startup into 10mR		140		ADC
Peak Short-Circuit Pulse Duration	Non-Latching, Startup into Short		16		ms
RMS Short-Circuit Current	Non-Latching, Startup into Short		15		ARMS
Dynamic Response					
Load Change 37.5A - 67.5A - 37.5A	$V_S=12\text{V}$ , $D_i/D_t=0.1\text{A}/\mu\text{s}$ , 6ft. input cable AWG 1/0, 6 ft load cable		$\pm 1.9$		VDC
Load Change 37.5A - 67.5A - 37.5A	$V_S=12\text{V}$ , $D_i/D_t=0.1\text{A}/\mu\text{s}$ , 20ft. input cable AWG 1/0, 6 ft load cable		$\pm 2.3$		VDC
Load Change 37.5A - 67.5A - 37.5A	$V_S=13.2\text{V}$ , $D_i/D_t=0.1\text{A}/\mu\text{s}$ , 6ft. input cable AWG 1/0, 6 ft load cable		$\pm 2$		VDC
	* See Note 2 below for definition of $V_S$				
Setting Time	To within 1% $V_{out}$ nom		500	1000	$\mu\text{s}$
Output Over-Voltage Protection	Non-Latching	32.7	34.8	37	VDC
Efficiency 100% Load 50% Load			96.0 96.8		% %

Note 1: Input and output voltages are measured at input and output terminals of the converter

Note 2:  $V_S$  - voltage at external power supply used for testing.  $V_{IN} < V_S$  due to voltage drop in input cable.

Note 3: All protections are non-latching. Once protection (OVP, OCP, input UVLO) are tripped converter enters into auto restart mode with 500 ms off time.



# 1100 - 2100 WATT MBH SERIES DC/DC CONVERTERS

**PRELIMINARY**



<b>28S12.100MBH Specifications</b>					
Conditions: $T_A=25^{\circ}\text{C}$ , $V_{IN} = 28\text{VDC}$ , unless otherwise noted:					
Input Parameter	Conditions	Min	Typ	Max	Units
<b>Absolute Maximum Ratings</b>					
Input Voltage					VDC
Non-Operating	Protected from reverse polarity on the input terminals	TBD		TBD	VDC
Operating		TBD		TBD	VDC
Voltage at ON/OFF input pin		TBD		TBD	VDC
<b>Input Characteristics</b>					
Operating Input Voltage Range		23	28	32	VDC
Maximum Input Current	$P_o = 1200\text{W} @ 23\text{VDC}$ in		TBD		A
Start-up Voltage	$V_{IN}$		TBD		VDC
Shut Down Voltage	$V_{IN}$		TBD		VDC
Input Stand-by Current	$V_{IN} = 28\text{V}$ , converter disabled		1.25	3	mA
Input No load Current	$V_{IN} = 28\text{V}$ , converter enabled		1.25	1.5	A

Output Parameter	Conditions	Min	Typ	Max	Units
<b>Output Characteristics</b>					
Output Voltage Set Point	$V_{IN} = 28\text{V}$ , $I_o = \text{TBD}$	11.4	12.0	12.6	VDC
Output Regulation Over Line and Load			$\pm 80$	$\pm 120$	mV
Total Output Voltage Range	Over sample, line, load, temperature & life	TBD		TBD	VDC
Output Voltage Ripple and Noise Peak to Peak RMS	20MHz Bandwidth, 10 $\mu\text{F}$ tantalum + 1 $\mu\text{F}$ ceramic Full Load Resistive Full Load Resistive	300 60		500 100	mV <sub>P-P</sub> mV <sub>RMS</sub>
Operating Output Current Range		0		100	A
Output DC Current Limit Inception	Non-Latching	110	120	140	A
Output DC Current Limit Shutdown	Output Voltage at which converter shuts down		TBD		VDC
Peak Short-Circuit Current	Non-Latching, Startup into 10mR		170		ADC
Peak Short-Circuit Pulse Duration	Non-Latching, Startup into Short		16		ms
RMS Short-Circuit Current	Non-Latching, Startup into Short		TBD		ARMS
Dynamic Response					
Load Change 50A - 90A - 50A	$V_s=28\text{V}$ , $Di/Dt=0.1\text{ A}/\mu\text{s}$ , 6ft. input cable AWG 1/0, 6 ft load cable		$\pm 1.9$		VDC
Load Change 50A - 90A - 50A	$V_s=28\text{V}$ , $Di/Dt=0.1\text{ A}/\mu\text{s}$ , 20ft. input cable AWG 1/0, 6 ft load cable		$\pm 2.3$		VDC
Load Change 50A - 90A - 50A	$V_s=29.2\text{V}$ , $Di/Dt=0.1\text{ A}/\mu\text{s}$ , 6ft. input cable AWG 1/0, 6 ft load cable		$\pm 2$		VDC
	* See Note 2 below for definition of $V_s$				
Setting Time	To within 1% $V_{out}$ nom		500	1000	$\mu\text{s}$
Output Over-Voltage Protection	Non-Latching	TBD	TBD	TBD	VDC
Efficiency 100% Load 50% Load			TBD		% %

Note 1: Input and output voltages are measured at input and output terminals of the converter

Note 2:  $V_s$  - voltage at external power supply used for testing.  $V_{IN} < V_s$  due to voltage drop in input cable.

Note 3: All protections are non-latching. Once protection (OVP, OCP, input UVLO) are tripped converter enters into auto restart mode with 500 ms off time.



# 1100 - 2100 WATT MBH SERIES DC/DC CONVERTERS

**PRELIMINARY**



28S13.100MBH Specifications					
Conditions: $T_A=25^{\circ}\text{C}$ , $V_{IN} = 28\text{VDC}$ , unless otherwise noted:					
Input Parameter	Conditions	Min	Typ	Max	Units
<b>Absolute Maximum Ratings</b>					
Input Voltage					VDC
Non-Operating	Protected from reverse polarity on the input terminals	TBD		TBD	VDC
Operating		TBD		TBD	VDC
Voltage at ON/OFF input pin		TBD		TBD	VDC
<b>Input Characteristics</b>					
Operating Input Voltage Range		23	28	32	VDC
Maximum Input Current	$P_O = 1350\text{W} @ 28\text{VDC in}$		TBD		A
Start-up Voltage	$V_{IN}$		TBD		VDC
Shut Down Voltage	$V_{IN}$		TBD		VDC
Input Stand-by Current	$V_{IN} = 28\text{V}$ , converter disabled		1.25	3	mA
Input No load Current	$V_{IN} = 28\text{V}$ , converter enabled		1.25	1.5	A

Output Parameter	Conditions	Min	Typ	Max	Units
<b>Output Characteristics</b>					
Output Voltage Set Point	$V_{IN} = 28\text{V}$ , $I_O = \text{TBD}$	12.8	13.5	14.2	VDC
Output Regulation Over Line and Load			$\pm 80$	$\pm 120$	mV
Total Output Voltage Range	Over sample, line, load, temperature & life	TBD		TBD	VDC
Output Voltage Ripple and Noise Peak to Peak RMS	20MHz Bandwidth, 10 $\mu\text{F}$ tantalum + 1 $\mu\text{F}$ ceramic Full Load Resistive Full Load Resistive	300 60		500 100	mV <sub>P-P</sub> mV <sub>RMS</sub>
Operating Output Current Range		0		100	A
Output DC Current Limit Inception	Non-Latching	110	120	140	A
Output DC Current Limit Shutdown	Output Voltage at which converter shuts down		TBD		VDC
Peak Short-Circuit Current	Non-Latching, Startup into 10mR		180		ADC
Peak Short-Circuit Pulse Duration	Non-Latching, Startup into Short		16		ms
RMS Short-Circuit Current	Non-Latching, Startup into Short		TBD		ARMS
<b>Dynamic Response</b>					
Load Change 50A - 90A - 50A	$V_S=12\text{V}$ , $D_i/D_t=0.1\text{ A}/\mu\text{s}$ , 6ft. input cable AWG 1/0, 6 ft load cable		$\pm 1.9$		VDC
Load Change 50A - 90A - 50A	$V_S=12\text{V}$ , $D_i/D_t=0.1\text{ A}/\mu\text{s}$ , 20ft. input cable AWG 1/0, 6 ft load cable		$\pm 2.3$		VDC
Load Change 50A - 90A - 50A	$V_S=13.2\text{V}$ , $D_i/D_t=0.1\text{ A}/\mu\text{s}$ , 6ft. input cable AWG 1/0, 6 ft load cable		$\pm 2$		VDC
	* See Note 2 below for definition of $V_S$				
Setting Time	To within 1% $V_{out\ nom}$		500	1000	$\mu\text{s}$
Output Over-Voltage Protection	Non-Latching	TBD	TBD	TBD	VDC
Efficiency 100% Load 50% Load			TBD		% %

Note 1: Input and output voltages are measured at input and output terminals of the converter

Note 2:  $V_S$  - voltage at external power supply used for testing.  $V_{IN} < V_S$  due to voltage drop in input cable.

Note 3: All protections are non-latching. Once protection (OVP, OCP, input UVLO) are tripped converter enters into auto restart mode with 500 ms off time.



# 1100 - 2100 WATT MBH SERIES DC/DC CONVERTERS

**PRELIMINARY**



General Specifications					
Parameter	Conditions	Min	Typ	Max	Units
Switching Frequency			400		KHz
ON/OFF Control Converter ON Converter OFF	Voltage at ON/OFF pin Voltage at ON/OFF pin	8 0	12	16 1.8	VDC VDC
Turn-on Time					
From ON/OFF Control	Time from ON/OFF going high to $V_o=90\%V_{OUT}(NOM)$ , Full Load (Resistive mode)	500	530	560	ms
By Input Voltage (ON/OFF= $V_{IN}$ )	Time from $V_{IN}$ reaching UVLO threshold to $V_o=90\% V_{OUT}(NOM)$ , Full Load (Resistive mode)	500	530	560	ms
Output Voltage Rise Time	Time from 10% to 90% $V_{OUT}(NOM)$		12		ms
Over Temperature Shutdown - OTP Base Plate Temperature	Non-Latching		100		°C
OTP Restart Hysteresis	Measured on the PCB		10		°C
Auto Restart Period			500		ms
Operating Surge Protection	100ms transient with 1msec rise time			30	VDC
Operating Temperature	At the top thermal interface Base Plate temperature	-40		95	°C
Non-operating Temperature	Ambient Storage Temperature	-55		100	°C
Connection Stud Torque			TBD		in lbs

Note 1: Input and output voltages are measured at input and output terminals of the converter

Note 2:  $V_s$  - voltage at external power supply used for testing.  $V_{IN} < V_s$  due to voltage drop in input cable.

Note 3: All protections are non-latching. Once protection (OVP, OCP, input UVLO) are tripped converter enters into auto restart mode with 500 ms off time.

Curve for 13S28.75MBH

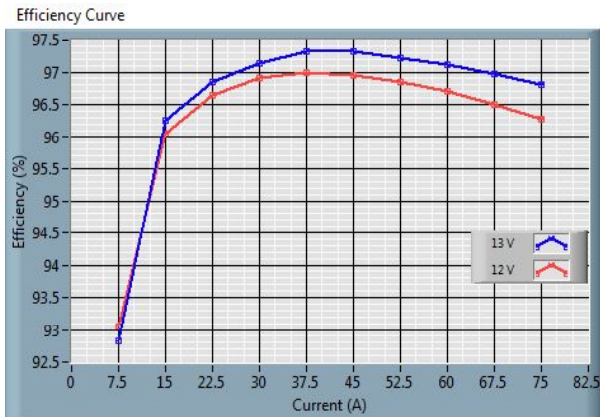

Curve for 13S28.75MBH

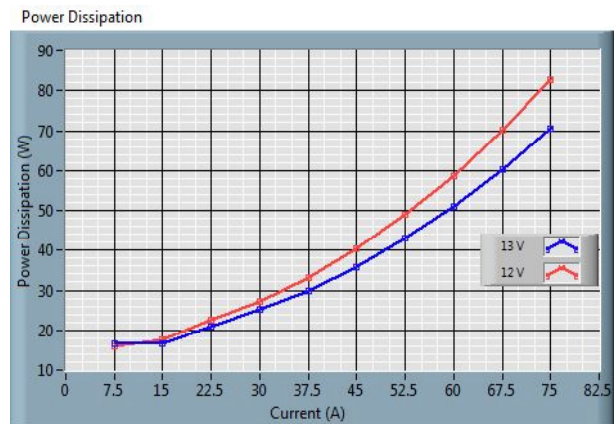

# 1100 - 2100 WATT MBH SERIES DC/DC CONVERTERS

**PRELIMINARY**



## Case Mechanicals:

Dimensions L x W x H: 9.0" x 6.5" x 1.25". Tolerance  $\pm 0.025$ "  
Unit Weight: 3.3 lbs

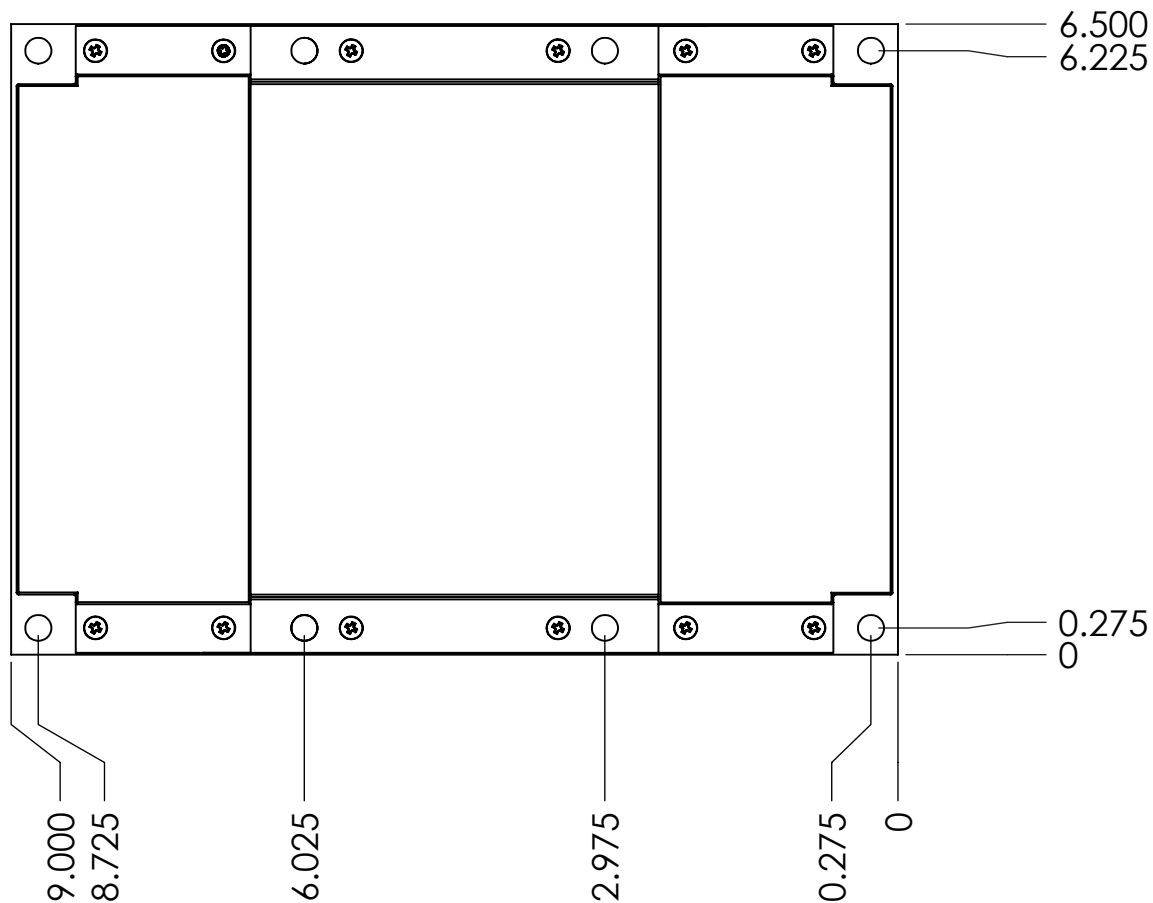
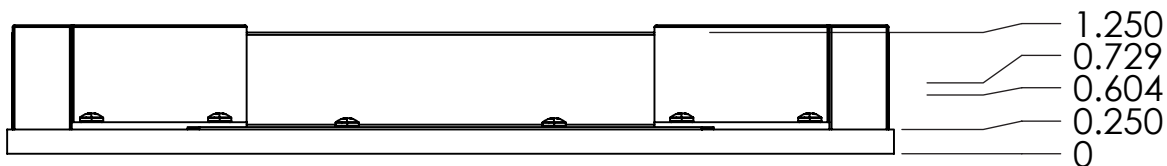

# 1100 - 2100 WATT MBH SERIES DC/DC CONVERTERS

**PRELIMINARY**



10 x  $\phi$  0.266 THRU

BOTTOM VIEW  
MOUNTING HOLE LOCATIONS

