

USER'S MANUAL

BIPOLAR POWER SUPPLY PBZ Series

PBZ20-20

PBZ40-10

PBZ60-6.7

PBZ80-5

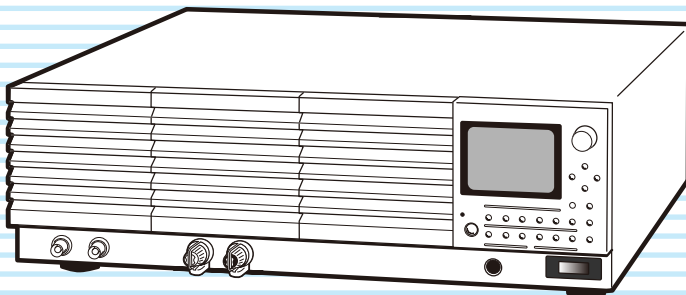

Installation and
Preparation

1

Basic Features

2

Memory,
Response,
and Configuration

3

Sequences

4

External Control,
Parallel Operation,
and Synchronization

5









Maintenance

6

App

About this manual

There are five PBZ Series Manuals listed as follows.

- Setup Guide  
This manual is intended for first-time users of this product. It provides an overview of the product and notes on usage. It also explains how to set up the product for testing the DUT. Always read this manual before using the product.
- Quick Reference  
This manual explains Panel description and operation briefly.
- Safety Information  
This document contains general safety precautions for this product. Keep them in mind and make sure to observe them.
- User's Manual  (this manual)
This manual is intended for first-time users of this product. It provides an overview of the product and notes on usage. It also explains how to configure the product, operate the product, perform maintenance on the product, and so on.
- Communication Interface Manual 
This manual contains details about remotely controlling the tester using SCPI commands.
The interface manual is written for readers with sufficient basic knowledge of how to control measuring instruments using a PC.

PBZ series manuals is intended for users of the product or persons teaching other users on how to operate the bipolar power supply.

PBZ series manuals assumes that the reader has electrical knowledge.

PDF is provided on the included CD-ROM.

Adobe Acrobat Reader is required to view the PDF file.

Product firmware versions

This manual applies to products with firmware versions 2.2X.

When contacting us about the product, please provide us with:

The model (marked in the top section of the front panel)

The firmware version (see page 22)

The serial number (marked in the top section of the rear panel)

Trademarks

Company names and product names used in this manual are generally trademarks or registered trademarks of the respective companies.

Copyrights

The contents of this manual may not be reproduced, in whole or in part, without the prior consent of the copyright holder.

The specifications of this product and the contents of this manual are subject to change without prior notice.

© 2009 Kikusui Electronics Corporation

Notations used in this manual

- The bipolar power supplies PBZ series are also referred to as the PBZ series and the PBZ in this manual.
- The word "PC" used in this manual is a generic term for personal computers and workstations.
- The following markings are used in this manual.

WARNING

Indicates a potentially hazardous situation which, if ignored, could result in death or serious injury.

CAUTION

Indicates a potentially hazardous situation which, if ignored, may result in damage to the product or other property.

NOTE

Indicates information that you should know.

DESCRIPTION

Explanation of terminology or operation principle.

See

Indicates reference to detailed information.



Indicates reference to detailed information product manual (CD-ROM).



Indicates the menu level of the item to be selected. The menu item to the left of the > symbol is a higher level menu.

SHIFT+key name

Indicates an operation that requires you to press a key indicated in blue letters while holding down the SHIFT key.

Safety Precautions

When installing this product, be sure to observe the precautions provided in "Precautions Concerning Installation Location" in the Safety information manual. Items specific to this product are given below.

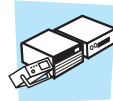

Installation

- Avoid locations where the product is exposed to high temperature or direct sunlight.
Do not install the product near a heater or in areas subject to drastic temperature changes.
Operating temperature range:
0 °C to +40 °C (+32 °F to +104 °F)
Storage temperature range:
-25 °C to +70 °C (-13 °F to +158 °F)
- Avoid humid environments.
Do not install the product in high-humidity locations near a boiler, humidifier, or water supply.
Operating humidity range:
20 %rh to 85 %rh (no condensation)
Storage humidity range: 0 to 90 %rh (no condensation)
Condensation may occur even within the operating humidity range. If this happens, do not use the product until the condensation dries up completely.

Product Overview

The PBZ is a high-voltage, large-current, fast-response, bipolar power supply. It supports four-quadrant operation, which means that it can source and sink both positive and negative voltages and currents. The internal AC signal or an external signal can be superimposed on the DC output. You can use the sequence feature to generate test signals for automotive and other electronic devices. Additionally, the PBZ can be used with a variety of loads to perform tests such as motor endurance tests, solenoid operation tests, and capacitor ripple tests.

Bipolar/unipolar mode

- In bipolar mode, the PBZ operates as a bipolar power supply.
- In unipolar mode, the PBZ operates as a power supply that generates positive voltage and positive and negative (source and sink) current.

Highly advanced, high speed signal generation

- The PBZ's frequency range is from DC to 100 kHz (in CV mode).
- The waveforms that the PBZ can generate using its internal signal source are sine, triangle, and square waveforms, and 16 user-defined arbitrary waveforms.

Soft start and soft stop

- The PBZ can increase the output over the specified time when output is turned on and decrease the output over the specified time when output is turned off. The output smoothly rises across the capacitive or inductive load.

Protection features

- The PBZ is equipped with overvoltage and overcurrent protection features. It also has protection features that turn the output off, turn the POWER switch off, and limit the output.

Preset memory

- You can save and load up to three sets of settings in CV mode and in CC mode.
- It is convenient to save signals that you use frequently and then load them at a later time to switch signals.

Sequence feature

- This feature automatically executes output patterns that you have edited as programs.
- You can easily create output patterns by using the program editing feature.

Synchronization feature

- You can synchronize multiple units so that their output turns on or off at the same time, or so that sequences are executed at the same time.

Parallel operation

You can operate from two units to five units in parallel (for three or more units, the units are installed in a smart rack for use).

A variety of remote interfaces

- RS232C, GPIB, and USB interfaces are included as standard. A LAN interface can be included as a factory option.

A wide range of applications

- Voltage variation tests for 12 V and 24 V automotive electronic devices
- Motor endurance and polarity switching tests
- Solenoid operation tests
- Capacitor ripple tests
- LCD inverter evaluation tests
- Medical instrument tests
- Power supply for Helmholtz coils
- Power supply for particle accelerators
- Constant current power supply for plating

Unipolar and bipolar power supplies

Unipolar power supplies (First- and third-quadrant operation)

The voltage polarity of general power supplies is fixed to a single polarity; thus they are called unipolar power supplies. If voltage is applied to a resistive load from a unipolar power supply, current that is proportional to the voltage flows in a fixed direction. The current flows from the output voltage's positive terminal to the output voltage's negative terminal. This is positive current. If you change the polarity of the voltage, the current flows in the opposite direction. This is negative current.

The operation of a unipolar power supply is shown on a graph of voltage (vertical axis) versus current (horizontal axis). First-quadrant operation is where positive current flows, and third-quadrant operation is where negative current flows.

The following figures show examples of the operation of unipolar power supplies. The points on each waveform (a, b, c, d, f, and g) are used to indicate the relative time relationship between the voltage and current waveforms. The corresponding points on each waveform indicate the same time positions relative to t_0 . This holds true for the following sections as well. These examples show that the voltage and current are in phase.

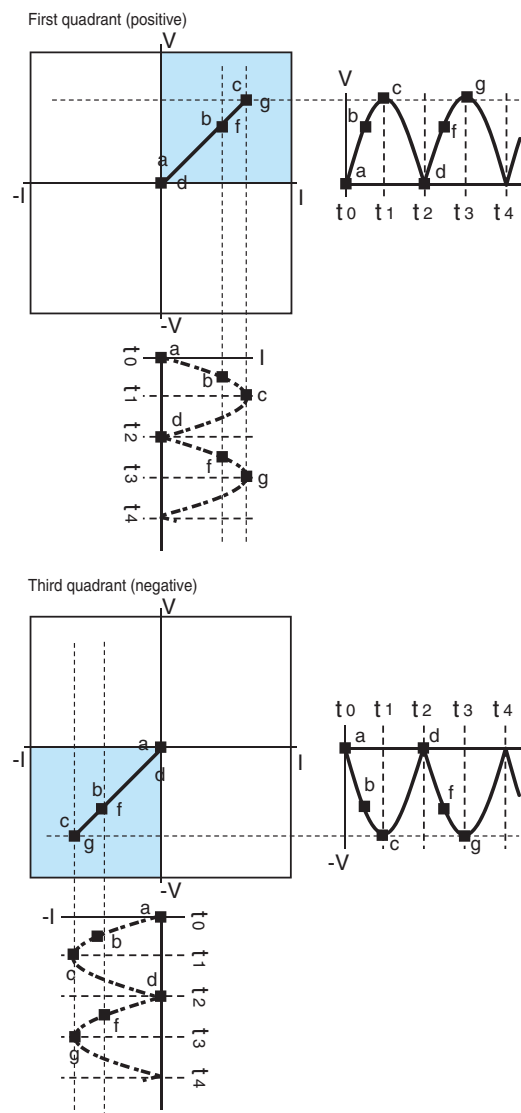

Bipolar power supplies

Unlike with resistive loads, when a power supply that alternates voltage polarity based on time is applied to an inductive or capacitive load, the current phase becomes lagging or leading to the voltage phase.

If this occurs, there are four possible combinations of the voltage and current polarities. This operation is shown on a graph of voltage (vertical axis) versus current (horizontal axis). The PBZ operates in all four quadrants (and thus the name four-quadrant operation). Power supplies that can operate in this manner are called bipolar power supplies.

The following figures show examples of four-quadrant operation. These examples show that the current phase becomes lagging to the voltage phase. The waveform passes through all four quadrants and creates an ellipse.

Section ab is in the second quadrant; section bcd is in the first quadrant; section df is in the fourth quadrant; and section fga is in the third quadrant. As the waveform continues, it repeatedly moves through all four quadrants.

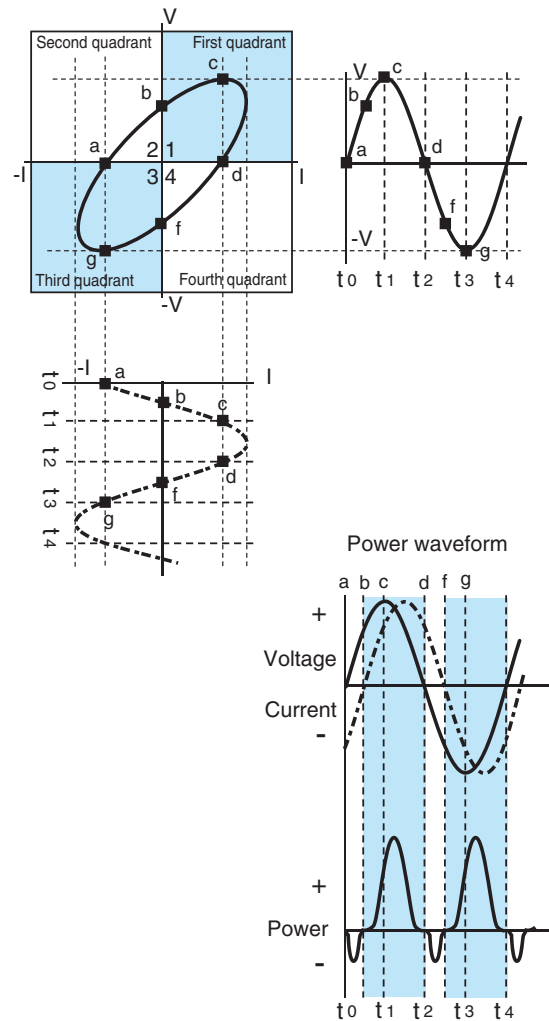

Four-quadrant operation and power

In four-quadrant operation, power is handled differently in each quadrant. This section explains the "Power waveform" figure on the left page.

Section ab is in the second quadrant, so the voltage is positive and the current is negative. Therefore, the power is negative. Hence, power is returned from the load to the power supply. Section bcd is in the first quadrant, so the both the voltage and the current are positive. Therefore, the power is positive. Hence, power is consumed by the load.

Section df is in the fourth quadrant, so the power is negative. Section fga is in the third quadrant, so power is positive (negative voltage \times negative current). The difference between the positive and negative power is the power that is consumed by the load.

Bipolar Amplifiers

Bipolar amplifiers use external signal sources in place of internal signal sources. You can set the amplification of the amplifier and whether the input signal is inverted or not. You can add the internal signal source that you specify from the panel.

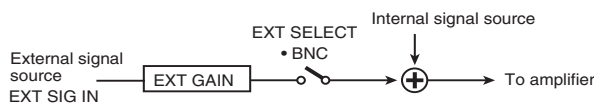

Unipolar mode

(First- and second-quadrant operation)

Unipolar mode is a characteristic feature of the PBZ. Voltage of a single polarity is generated, so this mode is called unipolar mode. The difference with a unipolar power supply is that, in this mode, you can make the current flow from the output voltage's positive terminal to the negative terminal or in the opposite direction (the current is bidirectional).

To make the PBZ operate in the third and fourth quadrants, you must reverse the connection between the OUTPUT terminal and the load, so that the voltage polarity is reversed.

The operation of the PBZ in unipolar mode is shown on a graph of voltage (vertical axis) versus current (horizontal axis). First-quadrant operation is where positive current flows, and second-quadrant operation is where negative current flows.

The following figures show examples of the PBZ operation in unipolar mode.

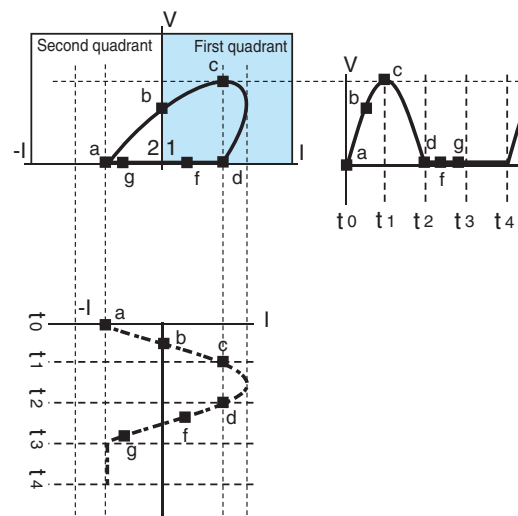

Contents

About this manual	2
Notations used in this manual	3
Safety Precautions	3
Product Overview	4
Unipolar and bipolar power supplies	5
Unipolar mode	6

1 Installation and Preparation

Checking the Package Contents	18
Rack Mounting the Product	19
Connecting the Power Cord	20
Turning On the Power	21
Before Turning the POWER Switch On	21
Turning the POWER Switch On	22
When the PBZ Does Not Start Properly	22
Turning the POWER Switch Off	23
Connecting the Load	24
Connecting to the OUTPUT Terminals	24
When Not Using the OUTPUT Terminals	25
Load Cables	26
Using the PBZ in Parallel Operation or with Fast Responses	27
Capacitive and Inductive Loads	27
Battery Load	28
Front Panel Output Terminals (Auxiliary Output Terminals)	28
Remote Sensing	29
Connecting the Sensing Terminals	29
Wiring Procedure	30
If You Are Inserting a Mechanical Switch between the OUTPUT Terminals and the Load	31

2 Basic Features

Operation Modes	34
Bipolar/Unipolar Mode	34
CV/CC Mode	35
Circuit Configuration	36
An Overview of Each Section and Related Operations	36
Circuit Common and I/O Terminals	37
Selecting a Signal Source	38
Signal Source Combinations	38
Selecting the DC Signal (Internal Signal Source)	40
Voltage, Current, and FINE Settings (Page 1/2)	40
Soft Start Time and Soft Stop Time (Page 2/2)	42
Selecting an AC Signal (Internal Signal Source)	43

Turning AC Signals On and Off (AC ON/OFF)	44
Setting the Waveform, Amplitude, and Frequency, and Turning the AC Signal On and Off (Page 1/5)	45
Start Phase and Square Wave Signal Duty Ratio (Page 2/5)	48
Frequency Sweep Mode and Time (Page 3/5)	49
Start and Stop Frequencies of the Frequency Sweep (Page 4/5)	50
The TRIG OUT Terminal's Function, and the Marker Frequency of the Frequency Sweep (Page 5/5)	51
Using External Control Signals	52
Using External Voltage (Control Signal J1)	52
Using External Resistance	54
Using the EXT SIG IN Signal (External Signal Source)	55
Gain Setting	55
Offset Setting	56
Turning Output On and Off and using Soft Start and Soft Stop	57
Turning the Output On and Off Immediately	57
The Output Soft Start and Soft Stop Features	58
Measurement Feature and Current Monitor Output	60
Measurement Feature Settings	61
Measurement Feature and Measurement Time (Page 1/2)	61
Measurement Start Trigger and Delay (Page 2/2)	62
Current Monitor Output	63
Protection Features and Alarms	64
Protection Feature Types	64
Alarm Feature	66
State Display of the Limit Features	67
How to Set and Check Activation Points	67
Basic Operations	70
Selecting Settings	70
Using the CONFIG Key	71
Using the Cursor Keys	71
Using the Rotary Knob	71
Using the Numeric Keys	72
Using the SHIFT Key	72
Prohibiting Key Operations (Key Lock)	72
Changing the Screen Brightness	73
Setting the PBZ to Local Mode	73
Setting the PBZ to Its Factory Default Settings	73
Buzzer	73

3 Memory, Response, and Configuration

Memory Types	76
--------------------	----

Differences between Preset and Setup	
Memory	76
Primary Usage	76
Preset Memory	77
Saving Settings to Preset Memory	77
Loading Preset Memory Entries	78
Setup Memory	79
Saving Settings to Setup Memory	80
Loading Setup Memory Entries	80
Response Setting	81
Setting Procedure	81
Examples of Responses	82
Load Resistance and Frequency Responses	83
Configuration (CONFIG)	84
List of CONFIG Settings	84
Setting and Viewing CONFIG Settings	85
CONFIG Setting Details	86
CONFIG[1]: Mode, Response, and Remote Sensing	86
CONFIG[2]: Signal Source, External Signal Circuit Gain, and the Power-On State....	87
CONFIG[3]: Synchronous Operation, Trigger Signals, and Output-On Logic	89
CONFIG[4]: Memory, Key Lock, and the Buzzer	90
CONFIG[5]: Master or Slave Unit in Parallel Operation	91
CONFIG[6]: Interface (GPIB, RS232C, USB, and LAN)	92
CONFIG[7]: Model Information	94

4 Sequences

Sequence Feature	96
Creating Sequences (Scripts, Programs, and Steps)	96
Sequence Execution Methods	97
Executing Sequences across Multiple Synchronized Units	98
Editing Programs and Steps	99
Editing Programs	100
Editing Steps	102
Step Settings	106
Step Settings	106
Practical Examples of Step Settings	110
Executing Programs	112
Executing Programs (RUN)	113
Aborting Programs (ABORT)	114
Pausing Programs (PAUSE)	114
Pausing Programs to Wait for Trigger Input Signals (WAIT)	115
Remedying Alarm Generation	115
Setting the Protection Features during Program Execution	116
Setting the Measurement Feature during Program Execution	116
Editing Scripts	117
Editing Script1	117
Editing Script2	119

Executing Scripts	121
Executing a Script (RUN)	122
Operations Other than Script Execution ..	123
Program Examples	124
Example 1: A DC Signal	124
Example 2: Superimposing an AC Signal on a DC Signal	126
Example 3: Changing a DC Signal Using a Trigger Signal Input	128
Example 4: Generating an AC Signal Using a Trigger Signal Input	130
Example 5: Performing a Ramp Transition That Takes Longer than 1000 Seconds	132

5 External Control, Parallel Operation, and Synchronization

External Control	134
About the J1 Connector	134
Controlling DC Signals (The DC Settings) ...	136
Using External Voltage	136
Using External Resistance	137
Turning Output On and Off	138
Shutting Down the PBZ	140
Signal Output	141
Parallel Operation	142
Using the Parallel Operation Kit	142
Installation	143
Connection	144
Remote Sensing	146
Turning the POWER Switch On	146
Specifying the Master Unit, the Slave Units, and the Number of Units in Parallel Operation	146
Turning Output On and Off	146
Turning the POWER Switch Off	146
Synchronization Feature	147
Connection Procedure	147
Configuring the Synchronization Feature	148
The Functions of the TRIG IN and TRIG OUT Terminals	148
Turning Output On and Off	149
Turning Output On when the POWER Switch Is Turned On	149
Setting the Signal Source	150
Executing Sequences	151
Clock Synchronization	152

6 Maintenance

Cleaning and Inspection	154
Backup Battery Replacement	155

7 Specifications

AC Input	158
----------------	-----

Rated Output.....	158
CV Mode Output	159
CC Mode Output	160
Measurement Display Feature	161
Protection Features.....	162
Control Feature	162
Signal I/O	163
Interface	164
Other Features	164
General	165
Dimensions	166

Appendix

A List of Factory Default Settings ...	168
B Output impedance	173
C Troubleshooting	177
D List of Error Messages	180
E Options	181
 INDEX	 185

Search by Topic

Preparation

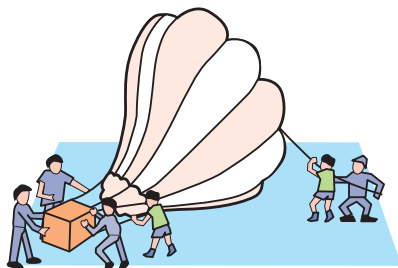

- I want to check the accessories.
→“Checking the Package Contents” 18

- The installation space is limited, so I want to check the installation conditions.
→“Installation” 3

- How do I connect the AC power supply?
→“Connecting the Power Cord” 20

- What kind of wires should be used to connect the load?
→“Load Cables” 26

- How do I set the communication conditions for remote control?
→See the “Communication interface manual” --

- How do I use parallel operation to increase the current capacity?
→“Parallel Operation” 142

- How do I rack mount the PBZ? What kind of parts are needed?
→“Options” 181

Setup



- How do I use the PBZ as a constant voltage power supply (CV mode)?
→“Operation Modes” 34

- How do I use the PBZ as a constant current power supply (CC mode)?
→“Operation Modes” 34

- How do I use the PBZ as a bipolar amplifier?
→“Using the EXT SIG IN Signal (External Signal Source)” 55

- How do I superimpose an AC signal onto the DC signal?
→“Selecting an AC Signal (Internal Signal Source)” 43

- How do I set the protection features to prevent damage to the load?
→“Protection Features and Alarms” 64

- How do I use remote sensing to stabilize the PBZ?
→“Remote Sensing” 29

- How do I check the CONFIG settings?
→“Configuration (CONFIG)” 84

- How do I initialize the PBZ to the factory default settings?
→“List of Factory Default Settings” 168

Operation

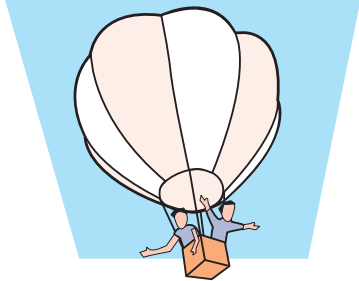

- I want to operate the PBZ at a given voltage. How do I register this voltage in the preset memory?
→“Preset Memory” 77
- How do I use a trigger signal to generate a signal?
→“Example 4: Generating an AC Signal Using a Trigger Signal Input” 130
- How do I edit sequence programs?
→“Step Settings” 106
- How do I control the PBZ using external resistances?
→“Using External Resistance” 137
- How do I control the PBZ using external voltage?
→“Using External Voltage” 136
- How do I stop a sequence that is executing?
→“Aborting Programs (ABORT)” 114
- I want to know more about connecting signals for synchronous operation.
→“Synchronization Feature” 147
- How do I use the external contact to turn output on and off?
→“Turning Output On and Off” 138

Maintenance

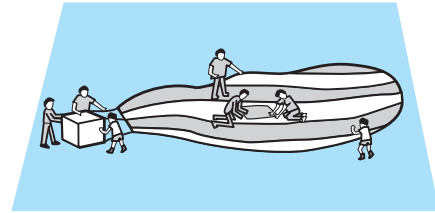

- I want to know about the backup battery's replacement period.
→“Backup Battery Replacement” 155

Troubleshooting

See “Troubleshooting” on page 177.

Front panel

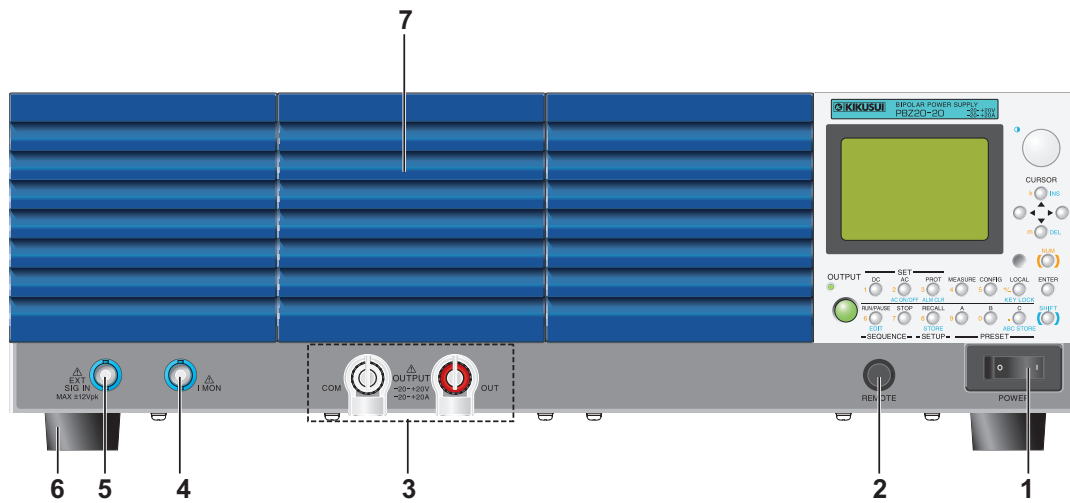

Display and controls

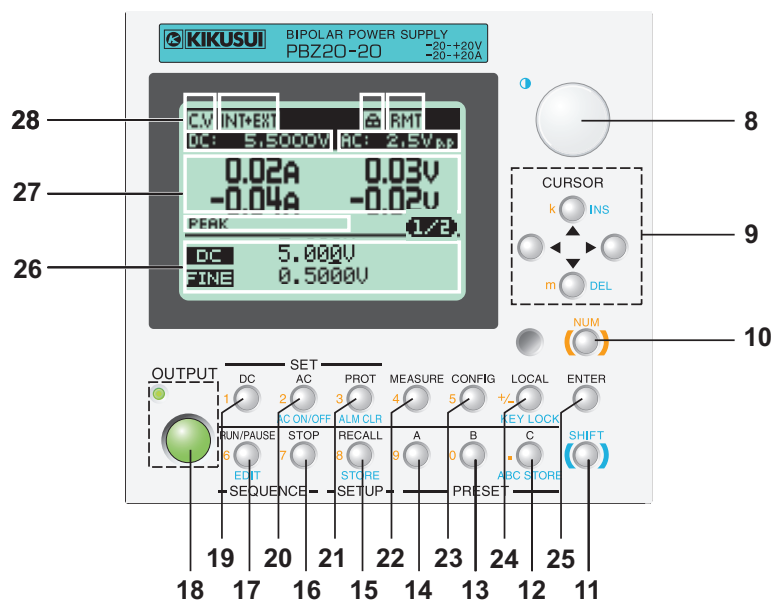

No.	Name	Function	See Page
1	POWER switch	Flip the switch to the () side to turn the power on. Flip it to the (O) side to turn the power off.	22
2	REMOTE connector	A connector for remote control (not used).	–
3	OUTPUT terminals	Auxiliary output terminals.	28
4	I MON terminal	Output current monitor output. Connect the common terminal to the output COM terminal.	63
5	EXT SIG IN terminal	External signal source input terminal. Connect the common terminal to the output COM terminal.	55
6	Rubber feet	Rubber feet in four locations.	–
7	Inlet holes	Air inlet holes for cooling the PBZ. Comes with a dust filter.	154

No.	Name	Function	See Page
8	Rotary knob	Used to make selections and change settings.	71, 41
	CURSORS ▲ ▼ ◀ ▶	Up, down, left, and right cursor keys.	
9	INS key, k key	Used to insert characters, and to insert kilo values.	71
	DEL key, m key	Used to delete and to insert milli values.	
10	NUM key	Used to switch to numeric input.	72
11	SHIFT key	Shift key.	72
	C key	Used to access preset memory C.	
12	ABC STORE key	Used to save all the preset memory entries.	
	. (Decimal point)	Used to enter a decimal point.	
	B key	Used to access preset memory B.	77
13	0	0	
	A key	Used to access preset memory A.	
14	9	9	
15	RECALL key	Used to load setup memory.	
	STORE key	Used to save setup memory.	79
	8	8	
	STOP key	Sequence feature. Used to stop program execution.	
16	7	7	
	RUN/PAUSE key	Sequence feature. Used to start and pause program execution.	113
17	EDIT key	Sequence feature. Used to edit programs.	
	6	6	
18	OUTPUT key	Used to turn output on and off.	57
19	DC key	Used to set the DC signal (DC or FINE).	
	1	1	40
	AC key	Used to set the AC signal.	
20	AC ON/OFF key	Used to turn the AC signal on and off.	43
	2	2	
	PROT key	Used to change the protection settings.	
21	ALM CLR key	Used to clear the alarm.	66
	3	3	
	MEASURE key	Used to access the measurement feature.	
22	4	4	61
	CONFIG key	Used to set up the CONFIG feature.	
23	5	5	85
	LOCAL key	Used to switch to local mode from remote mode.	
24	KEY LOCK key	Used to set the key lock.	72
	+/- key	Used to set the sign of the entered value (positive or negative).	
25	ENTER key	Used to confirm the input.	72
26	Lower display	Displays the settings that you enter.	
27	Center display	Displays the measured values (output monitor).	14
28	Upper display	Displays the status (operational state).	

Display

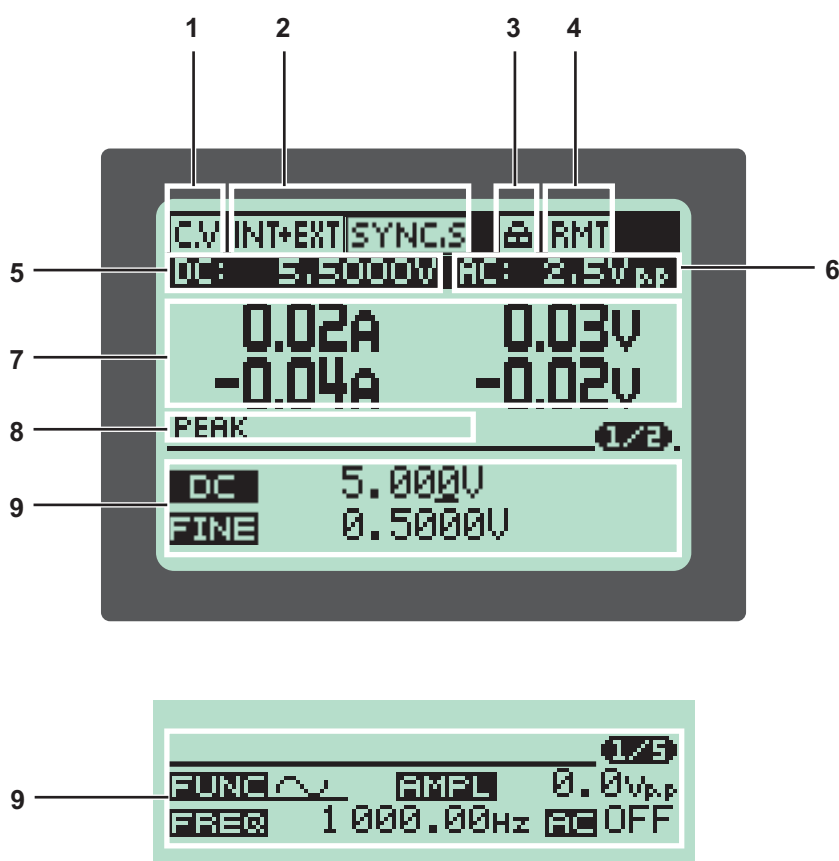

No.	Name	Function	See Page
1	CV	CV mode.	35
	CC	CC mode.	
2	INT	An internal signal source is selected.	38
	EXT	An external signal source is selected.	
	INT+EXT	A combination of internal and external signal sources is selected.	
	SYNC.M	Synchronization feature. This unit is the SYNC MASTER.	
3	SYNC.S	Synchronization feature. This unit is a SYNC SLAVE or the SYNC SLAVE END unit.	147
	Key lock	Displays the key lock state.	72
4	RMT	The PBZ is in remote mode.	73
5	DC:	Displays the DC signal setting (internal signal source). During soft start or soft stop, the changes in the setting are displayed.	40
6	AC:	Displays the AC signal setting (internal signal source). This appears when AC is set to ON.	43
7	Center display	Displays the measured current.	60
		Displays the measured voltage.	
8	DC	Appears when the DC measurement feature is selected.	61
	AC	Appears when the AC measurement feature is selected.	
	DC+AC	Appears when the DC+AC measurement feature is selected.	
	PEAK	Appears when the PEAK measurement feature is selected.	
9	Setting input area	Displays the settings that you enter. (This example shows the DC, FINE, and AC signal settings.)	-

Rear panel

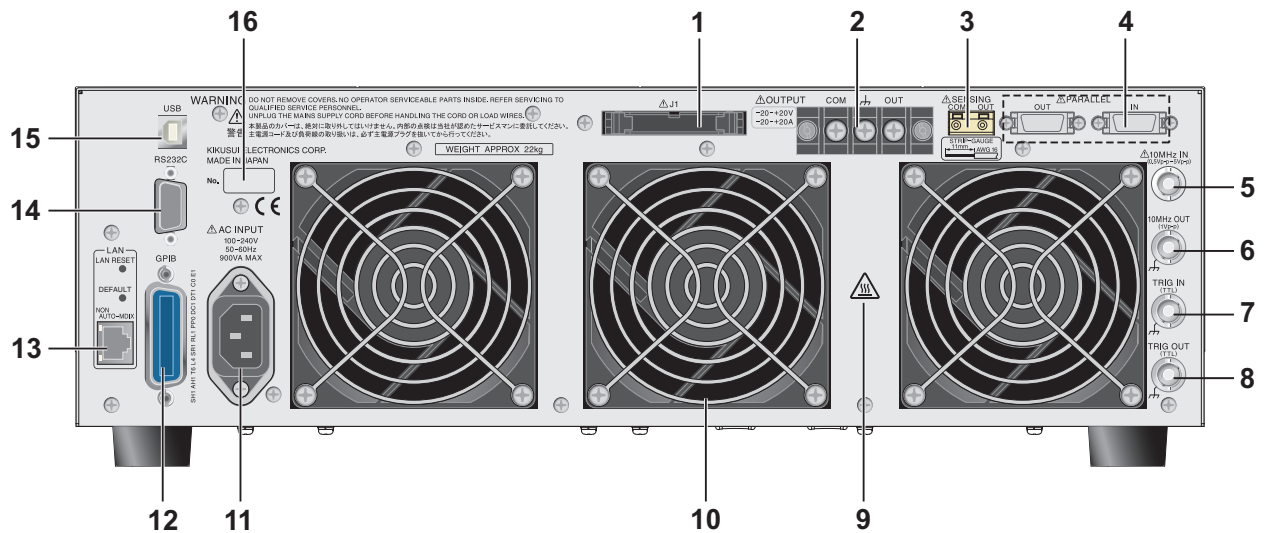

No.	Name	Function	See Page
1	J1 connector	External control connector	134
2	OUTPUT terminals	The OUT terminal is “hot,” and the COM terminal is common.	24
3	Sensing terminals	Terminals for connecting remote sensing wires.	29
4	PARALLEL terminals	Terminals for parallel operation.	143
5	10 MHz IN terminal	Clock signal input terminal. The common terminal is isolated from the chassis.	–
6	10 MHz OUT terminal	Clock signal output terminal. The common terminal is connected to the chassis.	–
7	TRIG IN terminal	Trigger signal input terminal. The common terminal is connected to the chassis.	106 148
8	TRIG OUT terminal	Trigger signal output. Transmits the synchronization signal for AC signals and the marker signal for frequency sweeps. The common terminal is connected to the chassis.	51 106 148
9	High temperature warning mark	This mark shows that the rear panel may become hot during operation and that you should be careful not to burn yourself.	24 144
10	Vent	Vent for cooling the PBZ.	–
11	AC INPUT	Power inlet.	20
12	GPIB	GPIB cable connector for controlling the PBZ remotely.	.. ¹
13	LAN (Factory option.)	Ethernet port for controlling the PBZ remotely. The LINK LED (green) illuminates when a link is established. The ACT LED (red) blinks when data is being transferred.	.. ¹
14	RS232C	RS232C port for controlling the PBZ remotely.	.. ¹
15	USB	USB port for controlling the PBZ remotely.	.. ¹
16	Serial number	The serial number of the PBZ.	–

¹See the “Communication interface manual”.

This page is intentionally blank.





1

Installation and Preparation

This chapter explains the steps from opening the PBZ package to turning the product on.

Checking the Package Contents

When you receive the product, check that all accessories are included and that the accessories have not been damaged during transportation.

If any of the accessories are damaged or missing, contact your Kikusui agent or distributor.

We recommend that you keep all packing materials, in case the product needs to be transported at a later date.

Accessories

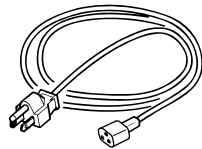
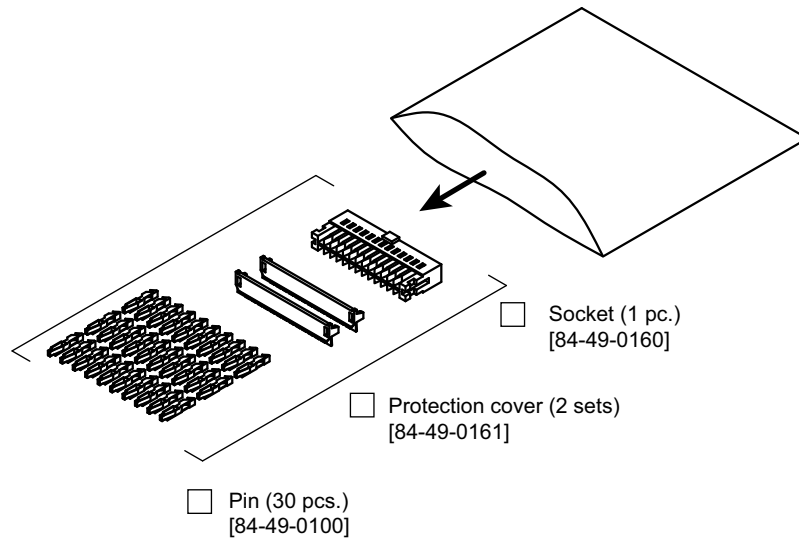

Rated voltage:
125 Vac
PLUG: NEMA5-15
[85-10-0740]

or

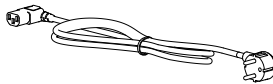

Rated voltage:
250 Vac
PLUG: CEE7/7
[85-10-1070]

or

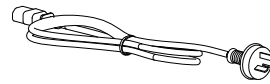

Rated voltage:
250 Vac
PLUG: GB1002
[85-10-0791]

Power cord

The power cord that is provided varies depending on the destination for the product at the factory-shipment.

Setup Guide (1 pc.)

Safety Information (1pc.)

Quick Reference
(English: 1pc., Japanese: 1pc.)

CD-ROM (1pc.)

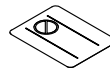

If necessary, attach to the product.

Heavy object warning label
[A8-900-153]

Rack Mounting the Product

See p. 181

Remove the rubber feet before rack mounting the product to a frame. The below figure shows how to remove the rubber feet. For details on rack mounting, see the KRB3-TOS or KRB150-TOS Operation Manual. Install the suitable support angles applying to the used rack system to support the instrument.

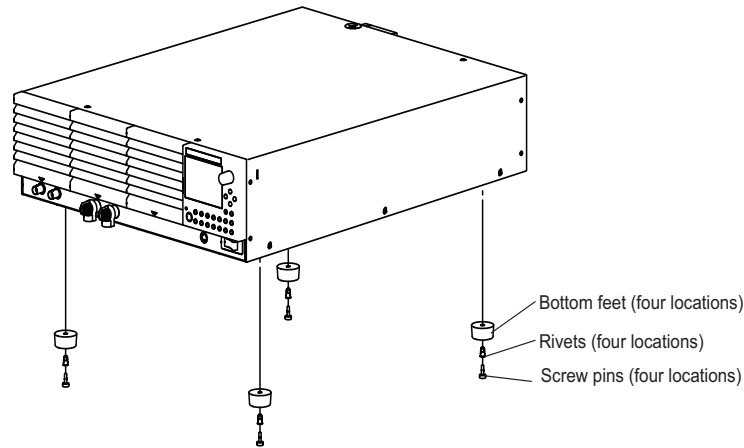

Removing the rubber feet

Remove the feet by detaching the screw pins while pulling the feet (four locations) downward. We recommend that you keep all the parts so that you can use them again when you detach the product from the frame.

Connecting the Power Cord



- **This product is an IEC Safety Class I equipment (equipment with a protective conductor terminal). To prevent electric shock, be sure to ground (earth) the unit.**
- **This product is grounded through the ground wire of the power cord. Be sure to connect the power plug to an outlet with an appropriate earth ground.**

NOTE

- Use the supplied power cord to connect to the AC line. If the supplied power cord cannot be used due to the rated voltage or the plug shape, have the cord replaced with an appropriate power cord of length 3 m or less by a qualified engineer. If obtaining a power cord is difficult, consult your Kikusui agent or distributor.
- In an emergency, the power cord with a plug may be used to disconnect the product from the AC line in an emergency. Connect the plug to an easily accessible power outlet so that the plug can be removed from the outlet at any time. Be sure to allow enough space around the power outlet.
- Do not use the supplied power cord on other instruments.

This product is an equipment of IEC Overvoltage Category II (energy-consuming equipment supplied from the fixed installation).

- 1 Turn the POWER switch off.**
- 2 Check that the AC power line complies with the input rating of the product.**

The voltage that can be applied is any of the nominal power supply voltages in the range of 100 Vac to 240 Vac. The frequency is 50 Hz or 60 Hz.
- 3 Connect the power cord to the AC inlet (AC INPUT) on the rear panel.**
- 4 Connect the power cord plug to an outlet with proper grounding.**

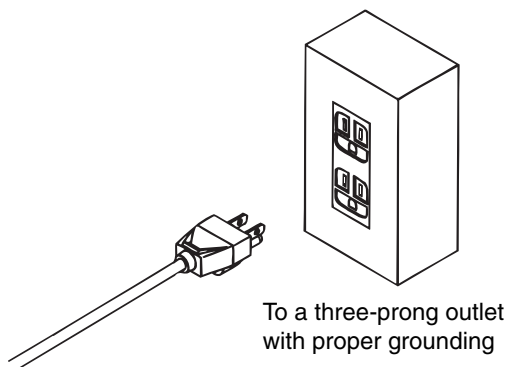

Turning On the Power

Before Turning the POWER Switch On

See p. 87

Function to perform when the POWER switch is turned on

The following functions can be performed when the PBZ turns on. Use **CONFIG** to set each of the functions.

Function to perform when the POWER switch is turned on	CONFIG
Turn output on	POWER ON > OUTPUT > <u>ON</u>
Execute a sequence	POWER ON > SEQ RUN > <u>PROG1 to 16</u> , <u>CV SCRIPT</u> , <u>CC SCRIPT</u>
Return to the previous state before the POWER switch was turned off	POWER ON > STATE > <u>LAST</u>
Return to the default state (DEFAULT)	POWER ON > STATE > <u>DEFAULT</u>

If the PBZ returns to its default state (DEFAULT), the SET, AC, PROT, MEASURE, and CONFIG front panel keys are reset to their factory default settings. The preset memory entries, setup memory entries, and sequences that are saved are not affected. (This manual differentiates between the terms “default values” and “factory default settings.”)

Precautions to prevent damaging the load (when the PBZ is set to automatically generate output)

If you use the CONFIG settings to set the PBZ to automatically generate output when the POWER switch is turned on, even if output was turned off when you last stopped using the PBZ, output is turned on with the previous output settings when you turn the POWER switch on.

- CAUTION**
- Check the output settings when you connect a new load to the PBZ. The new load may be damaged if the previous output settings cause the PBZ to generate an output that exceeds the new load’s capacity.

See p. 87 , p. 64

■ How to avoid damaging the load

- Use the CONFIG settings to set the PBZ so that output is not automatically turned on when the POWER switch is turned on.
- Set the protection features to match the load.

Turning the POWER Switch On

 p. 168

When you turn the POWER switch on for the first time after purchase, the PBZ starts with its factory default settings. Each time thereafter, the PBZ starts according to the setting that you selected as outlined in “Function to perform when the POWER switch is turned on” on page 24.

1 Check that the power cord is connected properly.

2 Turn the POWER switch on.

Flip the POWER switch to the (I) side to turn the PBZ on.

The following screen is displayed for approximately 2 seconds. At the same time, the PBZ begins its self test.

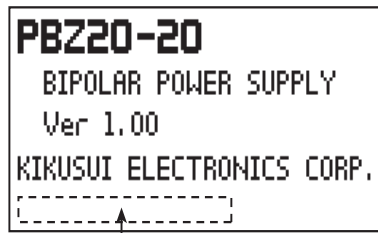

SELF TEST . . . PASS When the test passes
 SELF TEST . . . E101 When an error is detected

- All keys illuminate, excluding the CURSOR, SHIFT, and OUTPUT keys.
- The OUTPUT LED illuminates.
- The model name and firmware version are displayed. When the self test finishes, the PBZ starts. If no errors were detected, “PASS” is displayed. If an error was detected, the error number is displayed.

Example: PBZ20-20 Firmware Ver. 1.00

If you notice strange sounds, unusual odors, fire, or smoke around or from inside the PBZ, flip the POWER switch to the (O) side to turn the PBZ off, or remove the power cord plug from the outlet.

When the PBZ Does Not Start Properly

The PBZ will not start properly if:

- An error number is displayed after the self test.
- An error number is displayed when you press the OUTPUT key.
- “POWER OFF” is displayed.

If an error number is displayed after the self test

Follow the remedy that corresponds to the appropriate error number shown in the following table. If following the remedy shown here does not solve the problem, contact your Kikusui agent or distributor.

Error number	Message	Cause and remedy
E101	CALIBRATION DATA	An error was detected in the calibration values. There is an error in the calibration values that are stored in non-volatile memory. The PBZ must be calibrated properly. If this error number (E101) appears even after you have calibrated the PBZ, it may be malfunctioning.
E102	EEPROM DATA	An error was detected in the backup data. There is an error in the backup data that is stored in non-volatile memory. You can clear this error by starting the PBZ with the factory default settings.  p. 168
E901	INTERNAL ERROR	An error was detected in the internal system. There is an execution error in the internal system. Restart the PBZ.

If an error number is displayed when you press the OUTPUT key

Even if “PASS” is displayed on the screen after the self test completes, an error number (E001) may be displayed when you press OUTPUT. If this occurs, the input voltage is low, so the PBZ can not function properly after it turns on. Follow the remedy shown in the following table.

Error number	Message	Cause and remedy
E001	INPUT VOLTAGE	The input voltage is low, so the PBZ can not function properly. Turn the POWER switch off, and then check the voltage of the input power supply. The input voltage range that can be applied is 90 Vac to 250 Vac.

If “POWER OFF” is displayed

“POWER OFF” may be displayed on the screen while the PBZ is running. If this occurs, the input voltage is low, so the PBZ can not function properly. Turn the POWER switch off, and then check the voltage of the input power supply.

Turning the POWER Switch Off

● Flip the POWER switch to the (O) side to turn the PBZ off.

When you turn the POWER switch off, “POWER OFF” is displayed on the screen. Because the PBZ uses its residual power to show the display, it disappears after a few seconds.

The PBZ saves the panel settings (except the output on/off setting) that were in use immediately before the POWER switch was turned off. You can restore the PBZ to this saved state the next time that it starts.

If you switch the settings and then immediately turn the POWER switch off, the settings that were in use immediately before the PBZ turned off may not be saved.

- ⚠ CAUTION**
- After you turn the POWER switch off, wait at least 10 seconds after the fan stops before you turn the POWER switch back on. Turning the PBZ on too soon after you turn it off can cause damage to the inrush current limiter circuit, as well as reduce the life of components such as the POWER switch and the internal input fuses.

When the POWER switch is forcibly turned off

The PBZ’s POWER switch is normally turned off manually, but the PBZ is also equipped with a feature that forcibly turns the POWER switch off. When one of the following situations occurs, a message appears after the POWER switch turns off. Because the PBZ uses its residual power to display the message, it disappears after a few seconds.

- The overvoltage or overcurrent protection has been activated.
- A shutdown signal has been received through the external contact.

Connecting the Load

Connecting to the OUTPUT Terminals



To avoid electric shock, observe the following precautions.

- Turn the **POWER** switch off before you touch the **OUTPUT** terminals.
- Be sure to attach the **OUTPUT** terminal cover after you connect the load cables to the **OUTPUT** terminals.
- The rear panel may become hot during operation. If you touch it, you may burn yourself. Before you touch the rear panel, turn the **POWER** switch off, and allow a sufficient amount of time for the rear panel to become cool.

Standard components that are attached to the OUTPUT terminals when the PBZ is shipped	Quantity
Short bar (for the OUTPUT terminals)	1
8 mm M4 screws (for the OUTPUT terminals)	3
OUTPUT terminal cover	1
6 mm M3 screws (for the OUTPUT terminal cover)	2

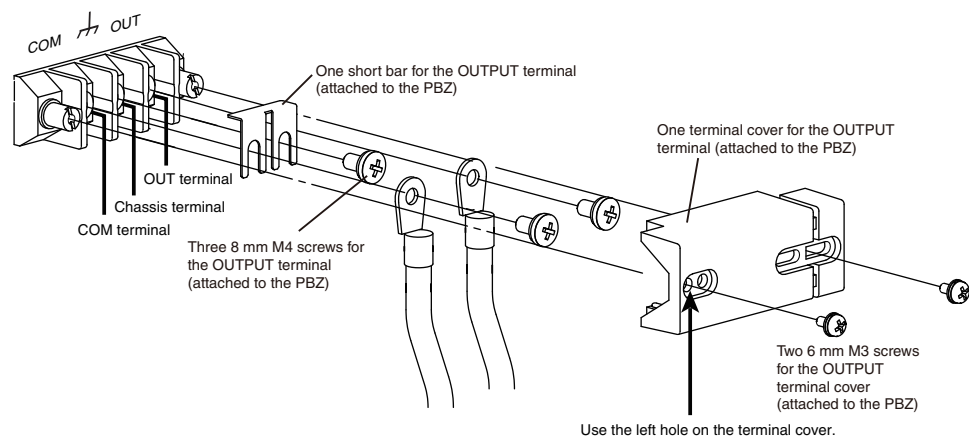

- Be sure to connect the chassis terminal and the COM terminal with the short bar. If you do not, the PBZ may not meet its specifications.

- 1 Turn off the POWER switch.**
- 2 Remove the OUTPUT terminal cover.**

The OUTPUT terminal cover screws will be reused later. These screws are easy to lose, so put them in a place that is easy to remember.
- 3 Using the short bar, connect the chassis and COM terminals.**
- 4 Attach crimping terminals to the load cables.**

Use crimping terminals that are designed for M4 screws.

5 Connect the load cables to the OUTPUT terminals.

The OUT terminal is “hot,” and the COM terminal is common. Twist the OUT and COM terminal cables together as much as you can and make the connection to the load as short as possible.

6 Attach the OUTPUT terminal cover.

Use the OUTPUT terminal cover screws to properly fix the OUTPUT terminal cover in place. Use the left hole on the OUTPUT terminal cover, as shown in the figure on page 27.

When Not Using the OUTPUT Terminals

When you are not using the OUTPUT terminals, attach the OUTPUT terminal cover as shown in the figure below.

1 Disconnect the load cables from the OUTPUT terminals.**2 Attach the OUTPUT terminal cover.**

Use the right hole on the OUTPUT terminal cover, as shown in the following figure. This slides the OUTPUT terminal cover to the left.

The lower portion of the OUTPUT terminal cover is designed so that it is difficult to insert fingers through the cover.

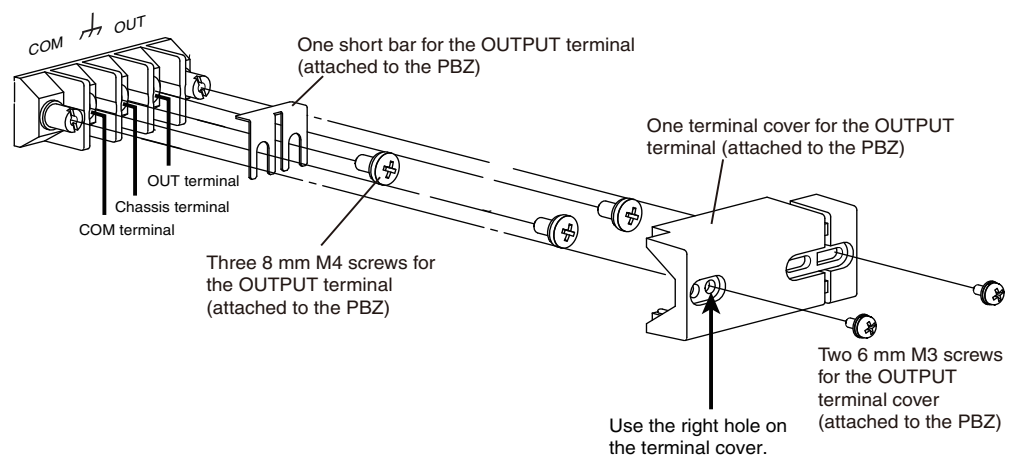

Load Cables



Improper use of load cables may lead to fire.

- Use load cables whose capacity is adequate for the PBZ's rated output current.

To avoid electric shock, observe the following precaution.

- Use load cables whose rated voltage meets or exceeds the PBZ's isolation voltage (500 Vdc).

Current capacity of load cables

If you use load cables whose capacity meets or exceeds the rated output current, even if the load is shorted, the cables will not be damaged. The load cables that you use must have a current capacity that allows the PBZ's rated output current to flow.

The cables' allowable current depends on the insulation's maximum allowable temperature.

A cable's temperature is determined by the resistive loss based on the current, the ambient temperature, and the cable's external thermal resistance. The following table shows the current capacity of heat-resistant vinyl cables that have a maximum allowable temperature of 60 °C when one of the cables is separated and stretched out horizontally in air in an ambient temperature of 30 °C. The current capacity must be reduced under certain conditions, such as when vinyl cables that have a low heat resistance are used, when the ambient temperature is 30 °C or greater, or when cables are bundled together and little heat is radiated.

Nominal cross-sectional area (mm ²)	AWG (reference cross-sectional area; mm ²)	Allowable current ¹ (A; Ta = 30 °C)	Kikusui-recommended current (A)
2	14 (2.08)	27	10
3.5	12 (3.31)	37	–
5.5	10 (5.26)	49	20
8	8 (8.37)	61	30
14	5 (13.3)	88	50
22	3 (21.15)	115	80
30	2 (33.62)	139	–
38	1 (42.41)	162	100

¹Excerpt from Japanese laws related to electrical equipment.

Using the PBZ in Parallel Operation or with Fast Responses

See p. 81

When you use the PBZ in parallel operation or with a fast response setting, you must wire the load and configure the response setting correctly and reduce the inductance. If these conditions are not met, the PBZ may oscillate or become unstable.

Load cables and inductance

Load cables have inductance L . If current I changes quickly, a large voltage is induced on both ends of the cable. This voltage is applied to both the PBZ and the load. The load cable's inductance L and voltage E that is induced according to the changes in current I (hereafter referred to as the induced voltage) are expressed as follows:

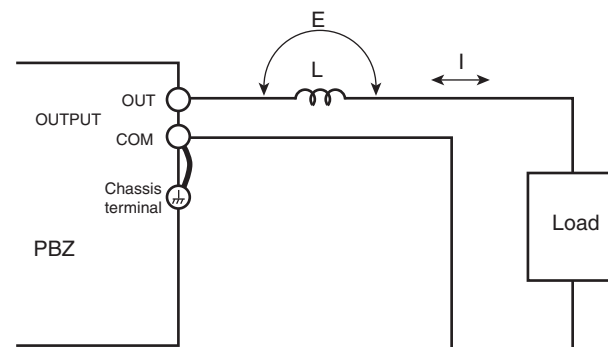

$$E = L \times (\Delta I / \Delta T)$$

- E: The induced voltage
- L: The wiring inductance
- ΔI : The change in current
- ΔT : The duration of time over which the current changes

NOTE

- Generally, a cable's inductance is 1 μH per meter of cable. If 2 meters of cable are used to wire the load (the total length of the cables that are connected to the OUT terminal and the COM terminal) and the current change is 10 A/ μs , the induced voltage is 20 V.

How to reduce the effect of wiring

See p. 183
See p. 81

See p. 142

- Use the low inductance load cable.
- If fast transient response is not required, increase the response setting. The value of $\Delta I / \Delta T$ is reduced, so even if you can't reduce the load cable's inductance, you can reduce the induced voltage.
- When you use the PBZ in parallel operation, use the parallel operation kit.
- Use the shortest cables possible to wire the load, and twist them.
- You can further reduce the effect of wiring by using busbars instead of cables. Arrange the busbar connected to the COM terminal parallel to the busbar connected to the OUT terminal, and connect the load as close to the PBZ as possible.

Capacitive and Inductive Loads

See p. 35 , p. 81 ,
p. 58

Oscillation may occur when the PBZ is connected to a capacitive load in CV mode or when the PBZ is connected to an inductive load in CC mode. To remedy this problem, increase the response setting or use the soft start and soft stop features.

If the protection features are activated when you turn the output on or off

See p. 58 , p. 64

If the PBZ is in CV mode and is connected to a capacitive load, OCP (overcurrent protection) may be activated when you turn output on or off. If the PBZ is in CC mode and is connected to an inductive load, OVP (overvoltage protection) may be activated when you turn output on or off. If these problems occur, use the soft start and soft stop features.

Battery Load

See p. 65

If you connect a device to the OUTPUT terminals that can supply power, like a battery, the PBZ is a load to the device. In this situation, there is a limit to the amount of power that the PBZ can consume. When the PBZ's sink power becomes too large, it limits its output current (the sink current to the PBZ) so that the sink power reduces to a constant value.

	Sink power ¹			
	PBZ20-20	PBZ40-10	PBZ60-6.7	PBZ80-5
Bipolar mode	100 W	180 W	200 W	200 W
Unipolar mode	400 W	400 W	402 W	400 W

¹The sink power values are typical values at an ambient temperature of 23 °C.

Front Panel Output Terminals (Auxiliary Output Terminals)

The OUTPUT terminals on the PBZ front panel are auxiliary output terminals. The specifications of the PBZ apply to the rear panel OUTPUT terminals. The front panel auxiliary output terminals may not meet the specifications.



To avoid electric shock, observe the following precaution.

- **Do not touch front OUTPUT terminals when the output is turned on. Also, be sure to use the binding post covers.**

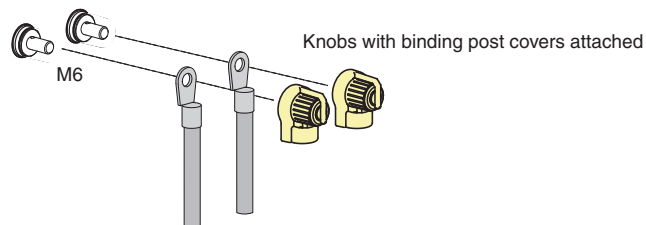

Remote Sensing

Remote sensing is a feature that is used to switch the voltage measurement point of CV/CC mode and the voltage feedback point of CV mode.

When remote sensing is enabled, the voltage measurement point of CV/CC mode and the voltage feedback point of CV mode are switched from the rear panel OUTPUT terminals to the contact points of the sensing terminals. Connecting the sensing terminals to the load (1) reduces the influence of the voltage drop caused by the resistive component of the load wires and by the load current and (2) allows measurement and compensation of the output voltage across the load. The compensation of the output voltage is effective to the voltage drop that is 1.8 V or less for a single line.

Remote sensing of CV mode has a protection feature. Even if the remote sensing wires are connected in reverse, shorted, or disconnected, the output voltage in CV mode is limited within the specified voltage \pm approximately 3.6 V. When the connection is fixed, the protection feature automatically recovers.

See p. 86

Use **CONFIG** to enable remote sensing.



To avoid electric shock and damage to the PBZ's internal circuits, observe the following precautions.

- Never wire the sensing terminals while the POWER switch is turned on.
- For sensing cables, use cables whose rated voltage is higher than the PBZ's isolation voltage (500 Vdc). Protect the uncovered sections of the shielded cable by using insulation tubes whose withstand voltage is greater than the PBZ's isolation voltage.
- Insert the cables so that the wire strands do not touch the chassis when they stick out of the sensing terminal. Also, insert the cables so that the stripped wires do not stick out of the terminal.

Connecting the Sensing Terminals

Cable type and stripping the coating off of the end of the cable

Use AWG24 to AWG16 (0.2 mm^2 to 1.25 mm^2) cables when connecting to the sensing terminals. Strip approximately 11 mm of coating from the end of the cable.

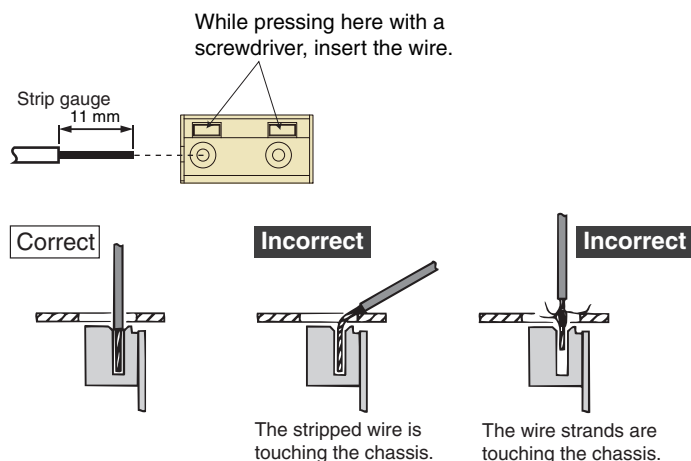

Wiring Procedure

- CAUTION** • This procedure may damage the internal workings of the PBZ. Do not mis-wire the SENSING terminals by wiring the cable for the OUT terminal to the COM terminal and vice-versa.

- 1 Turn off the POWER switch.**
- 2 Connect the sensing terminals to the load by using sensing cables.**

Connect both the OUTPUT OUT terminal and the SENSING OUT terminal to the same terminal on the load. Connect both the OUTPUT COM terminal and the SENSING COM terminal to the other terminal on the load.

To avoid noise induction, use a two-wire shielded cable to connect the sensing terminals. Connect the shield to the OUTPUT COM terminal. If you cannot use a shielded cable, twist the sensing cables from the OUT terminal and the COM terminal together.

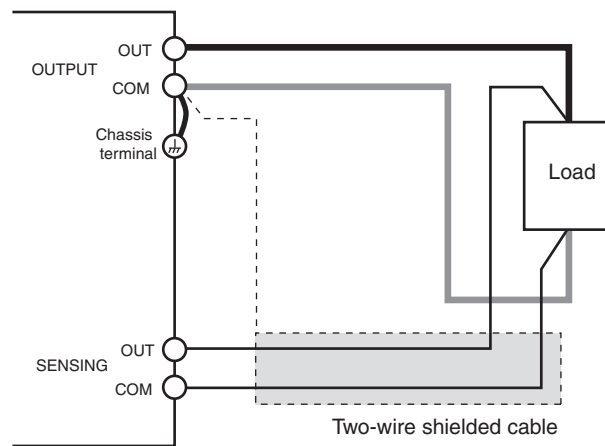

When remote sensing is enabled, if the sensing terminals are shorted, opened, or are wired in reverse, the sensing protection is activated, and the output voltage in CV mode is limited within the specified voltage \pm approximately 3.6 V. When the connection is fixed, the protection feature automatically recovers. Do not leave the PBZ while the sensing protection is activated.

If You Are Inserting a Mechanical Switch between the OUTPUT Terminals and the Load

If you want to insert a mechanical switch between the OUTPUT terminals and the load, be sure to include the sensing cables in the switch as shown in the figure below and turn on and off the load and sensing cables simultaneously. Before you turn the mechanical switch on or off, be sure to turn the output or the POWER switch off.

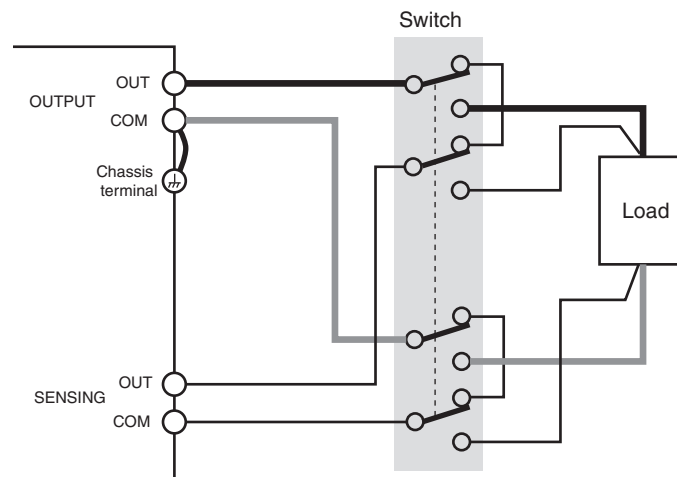

This page is intentionally blank.





2

Basic Features

This chapter explains the signal source, the output settings, how to turn the output on and off, and the protection features. Basic PBZ operations are explained at the end of the chapter.

Operation Modes

The PBZ has the following two operation mode settings. You can specify each setting individually.

- **Bipolar/unipolar mode**

In bipolar mode, the PBZ operates as a bipolar power supply.

In unipolar mode, the PBZ operates as a power supply that generates positive voltage and positive and negative (source and sink) current. If you want to generate negative voltage, reverse the output wiring.

- **CV/CC mode**

In CV mode, the PBZ operates as a constant voltage source.

In CC mode, the PBZ operates as a constant current source.

Bipolar/Unipolar Mode

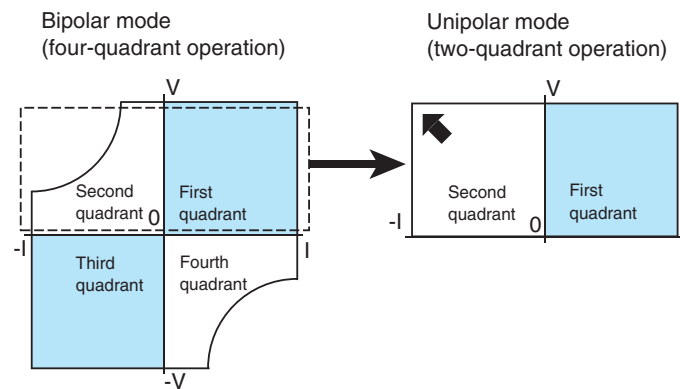

- **Bipolar mode**

As shown in the figure above, the operation of the PBZ in bipolar mode is shown on a graph of voltage (vertical axis) versus current (horizontal axis). The PBZ operates in all four quadrants (and thus the name four-quadrant operation).

- **Unipolar mode**

Unipolar mode is a characteristic feature of the PBZ. Voltage of a single polarity is generated, so this mode is called unipolar mode. A unipolar power supply can only generate current in a single direction, but when the PBZ operates in unipolar mode, it can handle bidirectional current (source and sink). As shown in the figure above, the operation of the PBZ in unipolar mode is shown on a graph of voltage (vertical axis) versus current (horizontal axis). The PBZ operates in the first and second quadrants (two-quadrant operation).

See p. 86

Use **CONFIG** to select the bipolar/unipolar mode.

Optimizing the operating region to reduce internal loss

In bipolar mode, when the PBZ is connected to a load that either generates or absorbs energy, if we consider the operation of the PBZ on a graph of voltage (vertical axis) versus current (horizontal axis), the PBZ operates mostly in the second and fourth quadrants. Because the output amplifier's internal loss is large, under some voltage and current conditions, the PBZ may not be able to produce output up to its rated values.

In these situations, if you set the PBZ to unipolar mode, you can greatly reduce the output amplifier's internal loss. As a result, the PBZ's operating range in the second quadrant will be expanded to its rated values.

Example of a battery load

The PBZ is in unipolar mode in the figure below. Using a battery load as an example, let's consider the output amplifier's internal loss.

CV mode

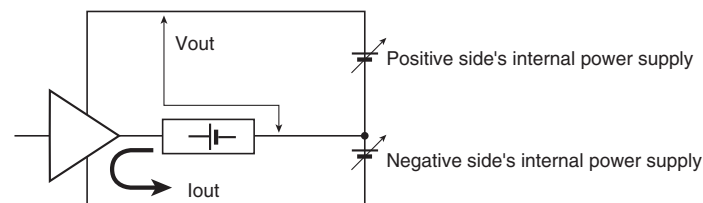

In what direction is the load current (the battery's discharge current) flowing? The load current does not flow in the positive side's internal power supply. All the load current flows in the negative side's internal power supply. The output amplifier's negative side requires very little of the internal power supply's voltage, but because a large current flows, the internal loss is great.

If we set the PBZ to unipolar mode, we can make the voltage of the output amplifier's negative side internal power supply nearly zero. Therefore, even if a large current flows, we can greatly reduce the internal loss. As a result, the PBZ's operating range in the second quadrant will be expanded to its rated values.

Operations in the third and fourth quadrants

See p. 24

In unipolar mode, the PBZ normally operates in the first and second quadrants (two-quadrant operation). The voltage is generated with a single polarity. The OUTPUT OUT terminal is positive, and the COM terminal is negative. Hence, to make the PBZ operate in the third and fourth quadrants, you must reverse the wiring that connects the OUTPUT OUT terminal and COM terminal to the load so that the voltage polarity is reversed.

CV/CC Mode

- **Select CV mode when you want the PBZ to operate as a constant voltage source.**
Even if the load current changes, the PBZ generates the specified signal source voltage.
- **Select CC mode when you want the PBZ to operate as a constant current source.**
Even if the load voltage changes, the PBZ generates the specified signal source current.

The PBZ does not change automatically from CV mode to CC mode. When output is on, you cannot switch between CV and CC modes.

See p. 86

Use **CONFIG** to select the CV/CC mode setting.

Circuit Configuration

The PBZ is designed so that you can select either an internal or external signal source. Then, the selected signal is fed to an output amplifier, and the amplified signal is generated. To make it easier to understand the operations explained in the following sections, the figure below shows a block diagram of the PBZ circuits.

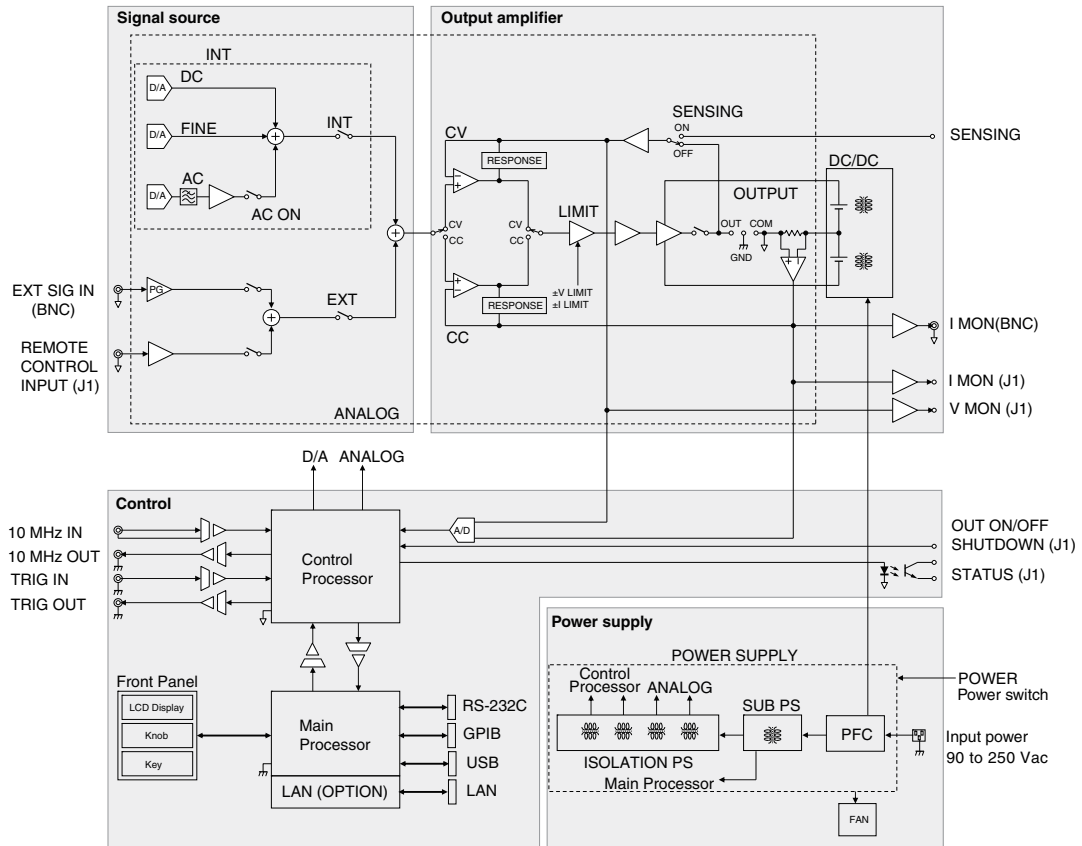

An Overview of Each Section and Related Operations

Signal source

Overview	Related operations	See
The circuit for internal and external signal sources. You can use both the internal and external signal sources at the same time.	"Selecting a Signal Source"	p. 38
	"Selecting the DC Signal (Internal Signal Source)"	p. 40
	"Selecting an AC Signal (Internal Signal Source)"	p. 43
	"Using External Control Signals"	p. 52
	"Using the EXT SIG IN Signal (External Signal Source)"	p. 55

Output amplifier

Overview	Related operations	See
Amplifies the signal from the selected signal source. It is designed to support both CV mode and CC mode. It consists of circuits such as those for the response, limit, and remote sensing features.	"Turning Output On and Off and using Soft Start and Soft Stop"	p. 57
	"Response Setting"	p. 81
	"How to Set and Check Activation Points"	p. 67

Control (protection feature, measurement feature, synchronization feature, etc.)

Overview	Related operations	See
This circuit controls all the PBZ features.	"Protection Features and Alarms"	<i>p. 64</i>
	"Measurement Feature and Current Monitor Output"	<i>p. 60</i>
	"Synchronization Feature"	<i>p. 147</i>

Power supply

Overview	Related operations	See
Supplies power to each circuit. The input voltage range is 90 Vac to 250 Vac. The primary circuit is equipped with a power factor correction circuit.	"Connecting the Power Cord"	<i>p. 20</i>

Circuit Common and I/O Terminals

The PBZ circuit commons are divided into the following two categories:

- Output amplifier and OUTPUT terminal
- Chassis

Each circuit common and its related terminals are shown in the following table. When you want to connect to an external device, see the appropriate page listed here.

Circuit common	Terminal name	See
Output amplifier and OUTPUT terminal	OUT and COM (front panel OUTPUT).	<i>p. 28</i>
	OUT and COM (rear panel OUTPUT).	<i>p. 24</i>
	EXT SIG IN.	<i>p. 55</i>
	I MON.	<i>p. 63</i>
	SENSING OUT and SENSING COM.	<i>p. 29</i>
	PARALLEL IN and PARALLEL OUT.	<i>p. 143</i>
	J1 terminal (use a photocoupler to isolate J1 STATUS' common from the OUTPUT terminals).	<i>p. 134</i>
Chassis	Chassis terminal (rear panel OUTPUT chassis terminal).	<i>p. 24</i>
	10 MHz IN (the common is isolated from the chassis, and the maximum isolation voltage is 42 V _{peak}).	<i>p. 152</i>
	10 MHz OUT.	<i>p. 152</i>
	TRIG IN.	<i>p. 107</i>
	TRIG OUT.	<i>p. 148</i>
	LAN, USB, GPIB, and RS232C.	--
	REMOTE.	<i>p. 12</i>

Selecting a Signal Source

When you use the PBZ, you can select both internal and external signal sources. The types of internal and external signal sources are as follows:

Internal signal sources	External signal sources
<ul style="list-style-type: none"> DC signal (DC or FINE) 	<ul style="list-style-type: none"> Internal signal source's DC signal (DC) that is controlled using a control signal (applied to the J1 connector)
<ul style="list-style-type: none"> AC signal (AC) 	<ul style="list-style-type: none"> The input signal that is applied to EXT SIG IN (BNC terminal)

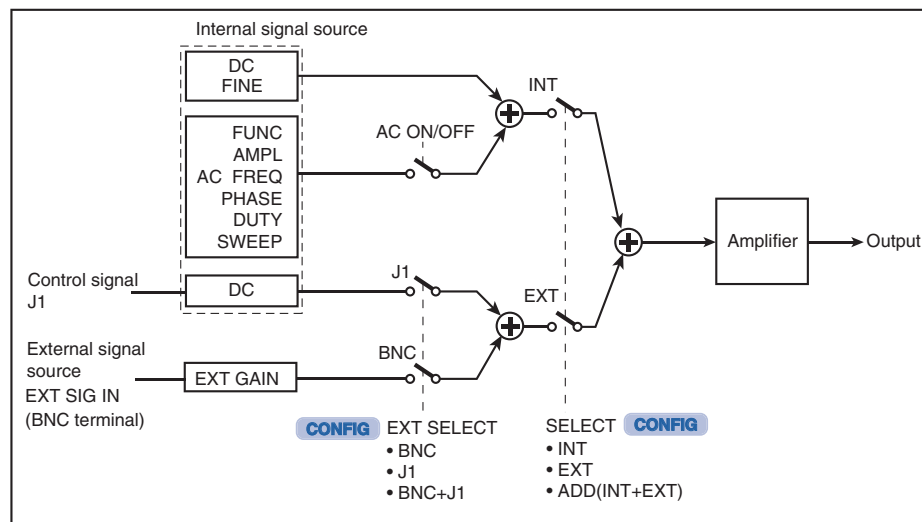

Signal Source Combinations

See p. 87

The different signal source combinations are shown on the recto side. Use **CONFIG** to select the signal source.

When you combine signal sources, if the signal sources change in opposite directions at the same time, glitches may be produced because of the differences in the responses of the signal sources.

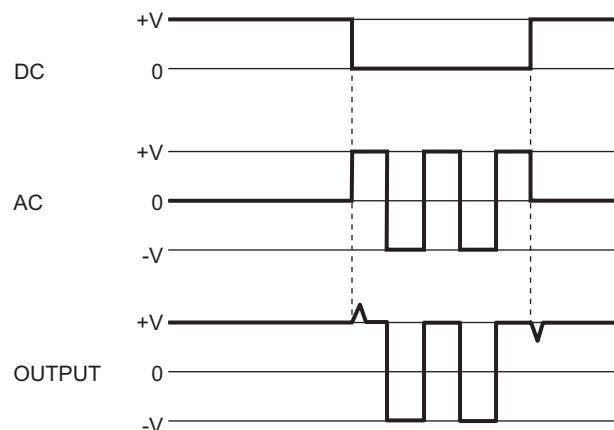

■ Using just the DC signal

This combination uses just the internal signal source's DC signal. This DC signal is always selected.

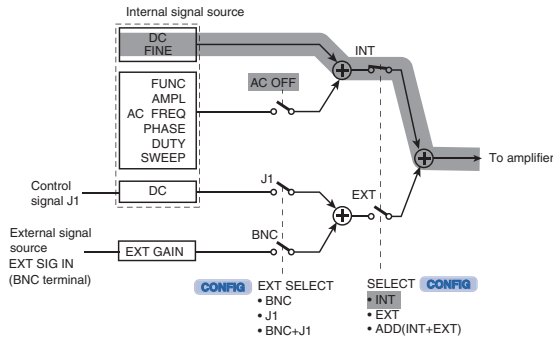

■ Adding an AC signal to the DC signal

This combination adds an AC signal to the internal signal source's DC signal.

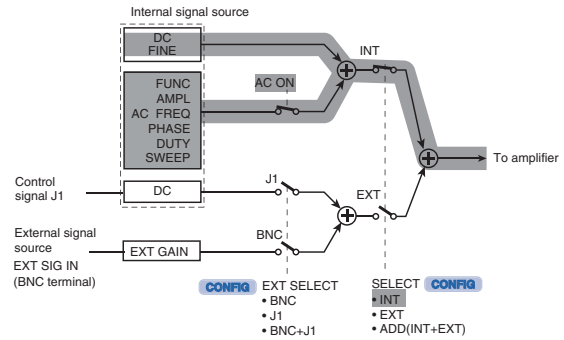

■ Using an external control signal (applied to the J1 connector)

This combination uses a control signal (applied to the J1 connector) to control the internal signal source's DC signal.

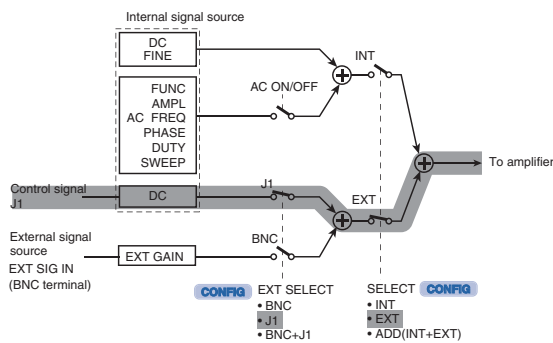

■ Using the signal that is applied to EXT SIG IN

This combination makes the PBZ into a bipolar amplifier that amplifies the input signal that is applied to EXT SIG IN (the BNC terminal). You can set the gain and the polarity (inverted or not inverted) of the amplifier.

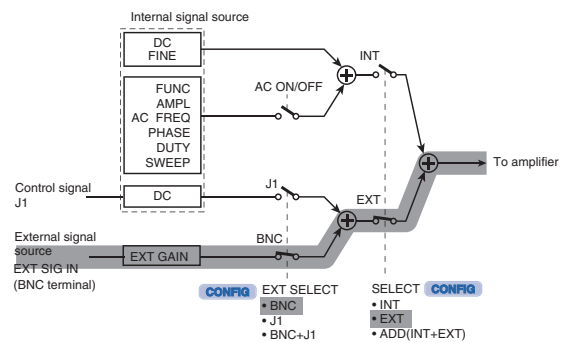

■ Combining the signal that is applied to EXT SIG IN and an external control signal (applied to J1)

This combination adds the input signal that is applied to EXT SIG IN (the BNC terminal) and the internal signal source's DC signal that is controlled using a control signal (applied to the J1 connector).

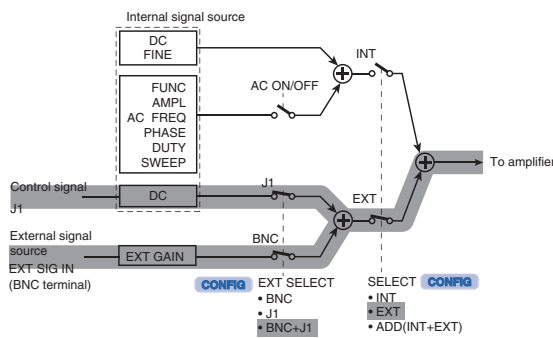

■ Combining internal and external signal sources

In this combination, the external signal source is the input signal that is applied to EXT SIG IN (the BNC terminal) and the internal signal source's DC signal that is controlled using a control signal (applied to the J1 connector). The internal signal source is the DC and AC signals. This combination adds all the different signals together.

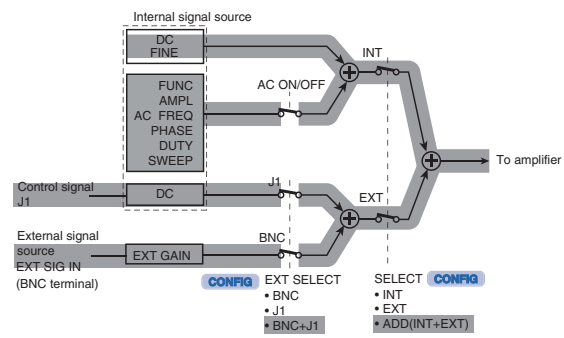

Selecting the DC Signal (Internal Signal Source)

This section explains how to configure the PBZ to generate the internal signal source's DC voltage and current. Set the voltage in CV mode and the current in CC mode. If you set the soft start time and the soft stop time, the soft start and soft stop features will be enabled.

Depending on the settings, there are two setup screens. Press the DC key to switch between pages (page 1/2 and page 2/2). If you have used **CONFIG** to set SELECT (the signal source selection) to EXT (an external signal source), pressing the DC key will have no effect.

See p. 87

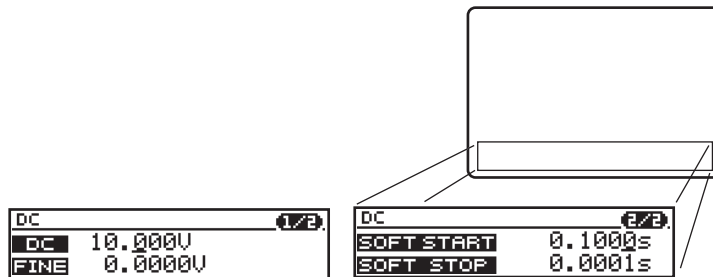

- 1 Press DC.**
The DC key illuminates, and the DC setup screen (1/2) appears.
- 2 Press DC to select the page that you want to edit.**
The page switches.
- 3 Use the up and down cursor keys to select a setting.**
The cursor moves to the setting that you want to specify. You can switch the page by continuously pressing the up or down cursor key.
- 4 To enter a number, use the left and right cursor keys to move the cursor to the digit that you want to specify.**
This operation is unnecessary if you are using the numeric keys.
- 5 Use the rotary knob or numeric keys to specify the value.**
If you fix the value that you specified using the rotary knob, the input value is confirmed. If you are using the numeric keys to specify the value, press ENTER to confirm the input value.
- 6 To specify other settings, return to step Procedure 2.**
- 7 To set up other features, press a key other than DC.**
The DC key turns off. The DC setup completes, and the PBZ switches to the feature for the key that you pressed.

See p. 71

Voltage, Current, and FINE Settings (Page 1/2)

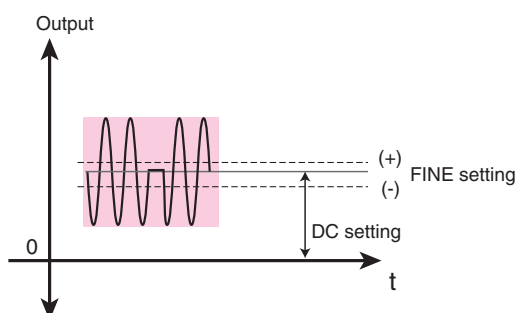

DC

The input range of the CV mode's DC setting (voltage) differs between bipolar and unipolar modes. The input range of the CC mode's DC setting (current) is the same (see the following tables).

● Input range of the DC setting

Bipolar mode

	CV (Factory default setting: 0 V)		CC (Factory default setting: 0 A)	
	Input range	Resolution	Input range	Resolution
PBZ20-20	-21.000 V to +21.000 V	0.001 V	-21.000 A to +21.000 A	0.001 A
PBZ40-10	-42.000 V to +42.000 V	0.001 V	-10.500 A to +10.500 A	0.001 A
PBZ60-6.7	-63.000 V to +63.000 V	0.002 V	-7.035 A to +7.035 A	0.001 A
PBZ80-5	-84.000 V to +84.000 V	0.002 V	-5.250 A to +5.250 A	0.001 A

Unipolar mode

	CV (Factory default setting: 0 V)		CC (Factory default setting: 0 A)	
	Input range	Resolution	Input range	Resolution
PBZ20-20	0.000 V to +21.000 V	0.001 V	-21.000 A to +21.000 A	0.001 A
PBZ40-10	0.000 V to +42.000 V	0.001 V	-10.500 A to +10.500 A	0.001 A
PBZ60-6.7	0.000 V to +63.000 V	0.002 V	-7.035 A to +7.035 A	0.001 A
PBZ80-5	0.000 V to +84.000 V	0.002 V	-5.250 A to +5.250 A	0.001 A

NOTE

- If the sum of the DC value and the FINE value; the sum of the DC value and the peak AMPL value; or the sum of the DC value, the FINE value, and the peak AMPL value is close to the rated value, the DC value that you enter must not cause the rated value to be exceeded.

FINE

You can make fine adjustments (increases or decreases) to the DC setting.

● Input range of the FINE setting

	CV (Factory default setting: 0 V)		CC (Factory default setting: 0 A)	
	Input range	Resolution	Input range	Resolution
PBZ20-20	-1.0000 V to +1.0000 V	0.0001 V	-1.0000 A to +1.0000 A	0.0001 A
PBZ40-10	-2.0000 V to +2.0000 V	0.0001 V	-0.5000 A to +0.5000 A	0.0001 A
PBZ60-6.7	-3.0000 V to +3.0000 V	0.0002 V	-0.3350 A to +0.3350 A	0.0001 A
PBZ80-5	-4.0000 V to +4.0000 V	0.0002 V	-0.2500 A to +0.2500 A	0.0001 A

The FINE setting is always applied to the DC setting. If you do not need to make fine adjustments to the DC setting, set the FINE setting to zero.

In unipolar mode, there is a limitation to the input range of the CV mode's FINE setting (voltage).

The value of (DC setting - FINE setting) must be positive.

NOTE

- If the sum of the FINE value and the DC value; the sum of the FINE value and the peak AMPL value; or the sum of the FINE value, the DC value, and the peak AMPL value is close to the rated value, the FINE value that you enter must not cause the rated value to be exceeded.
- In the sequence feature, the FINE setting is not valid.

Soft Start Time and Soft Stop Time (Page 2/2)

See p. 58

The soft start time is the time that the PBZ takes to raise the output value from zero to the DC setting when output is turned on.

The soft stop time is the time that the PBZ takes to lower the output value from the DC setting to zero when output is turned off.

You can only specify the soft start and soft stop times for the DC setting. These settings are not applied to the FINE setting.

You can also cancel the soft start and soft stop features while they are operating.

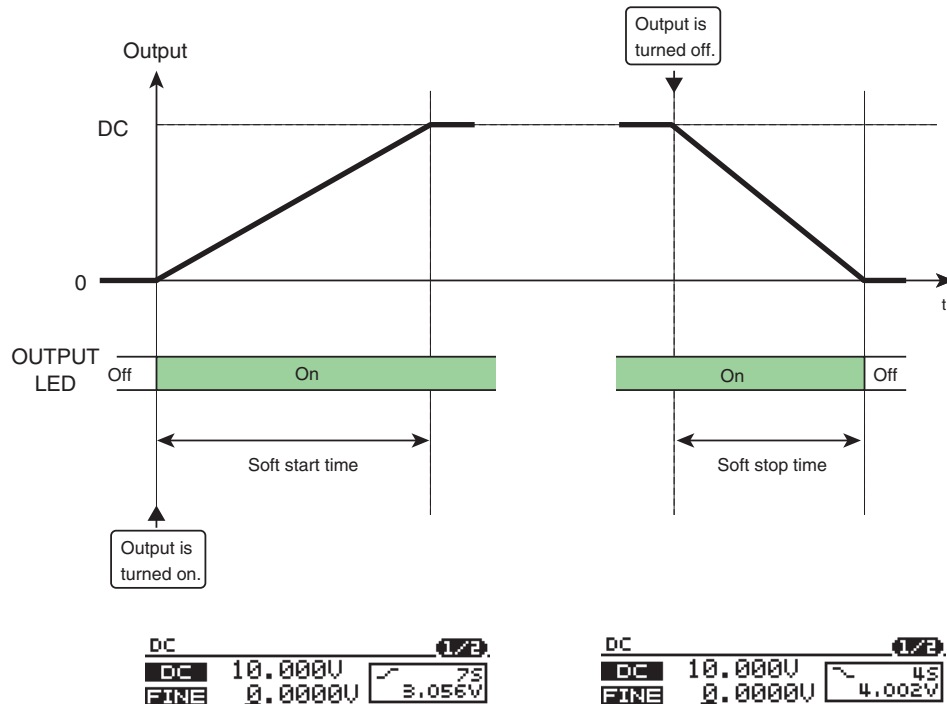

Soft start

You can specify the time that the PBZ takes to raise the output value from zero to the DC setting when output is turned on as the soft start time.

Soft stop

You can specify the time that the PBZ takes to lower the output value from the DC setting to zero when output is turned off as the soft stop time.

● Input range of the soft start and soft stop settings

CV/CC mode	Input range	Resolution	Factory default setting
CV and CC	0.1 ms to 1000 s (1000.0000 s) or OFF	0.1 ms	OFF

See p. 89

If you use **CONFIG** to set SYNCHRONOUS > OPERATION to SLAVE or SLAVE(E), the soft stop feature is disabled, so the SOFT STOP setting is set to OFF.

Selecting an AC Signal (Internal Signal Source)

This section explains how to set the PBZ to generate an AC signal from the internal signal source. Switch between setup screens to select the setting that you want to specify. Set the voltage in CV mode and the current in CC mode.

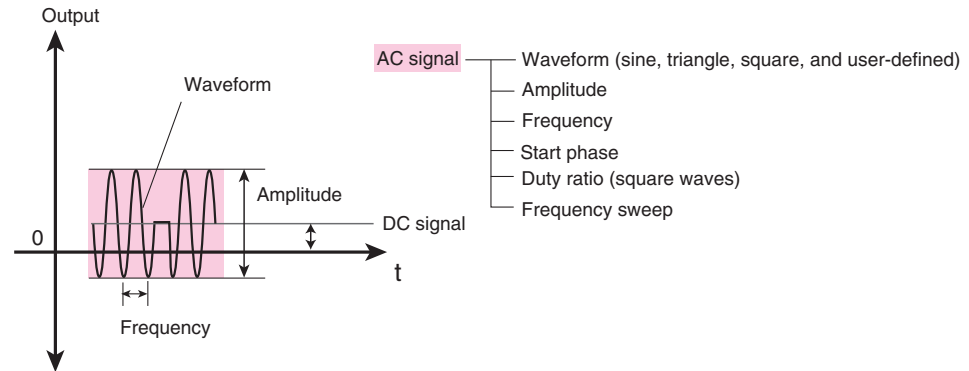

Depending on the settings, there are five setup screens. Press the AC key to switch between pages (page 1/5 to page 5/5). If you have used **CONFIG** to set SELECT (the signal source selection) to EXT (an external signal source), pressing the AC key will have no effect.

See p. 87

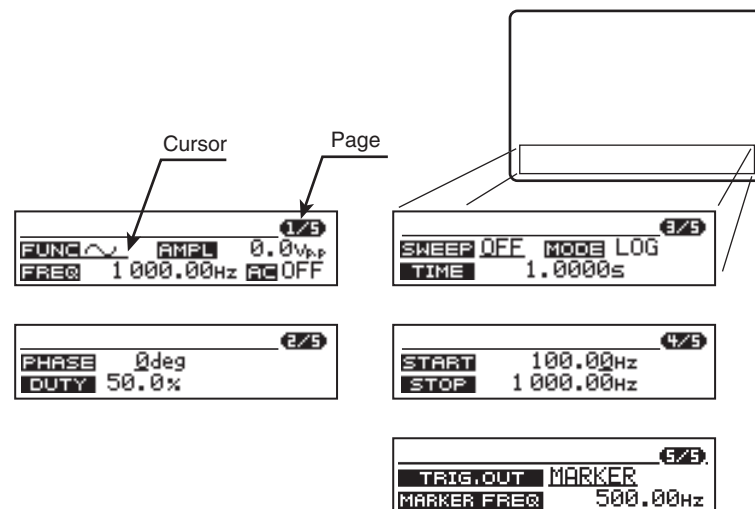

- 1 Press AC.**
The AC key illuminates, and the AC setup screen (1/5) appears.
- 2 Press AC to select the page that you want to edit.**
The page switches.
- 3 Use the up and down cursor keys to select a setting.**
The cursor moves to the setting that you want to specify. You can switch the page by continuously pressing the up or down cursor key.
- 4 To enter a number, use the left and right cursor keys to move the cursor to the digit that you want to specify.**
This operation is unnecessary if you are using the numeric keys.

 p. 71

5 Use the rotary knob or numeric keys to specify the value.

If you fix the value that you specified using the rotary knob, the input value is confirmed. If you are using the numeric keys to specify the value, press ENTER to confirm the input value.

6 To specify other settings, return to step Procedure 2.

7 To set up other features, press a key other than AC.

The AC key turns off. The AC setup completes, and the PBZ switches to the feature for the key that you pressed.

Turning AC Signals On and Off (AC ON/OFF)

To turn on or off the internal signal source's AC signal that is superimposed on the DC signal, follow the procedure below.

1 Press AC ON/OFF (SHIFT + AC).

AC is displayed in the status display area. The specified AC signal is superimposed on the DC signal.

2 Press AC ON/OFF (SHIFT + AC) again.

AC disappears from the status display area. The AC signal is turned off.

■ There are times when the PBZ cannot turn on the AC signal

If the AC signal is off, you can specify a value for the AC signal's AMPL setting that is anywhere within its input range without regard to the DC signal (the DC setting + the FINE setting). However, if the sum of the DC setting, the FINE setting, and the AMPL setting exceeds the rated value, the PBZ cannot turn the AC signal on. Change the value of (the DC setting + the FINE setting) and the AMPL setting so that the sum of these values is less than or equal to the rated value.

 p. 45





Setting the Waveform, Amplitude, and Frequency, and Turning the AC Signal On and Off (Page 1/5)

Except for the AMPL setting, the PBZ uses the values that you specify for the settings that are explained in this section in both bipolar mode and unipolar mode. The settable ranges are the same for both bipolar mode and unipolar mode.

FUNC

Use the FUNC setting to select the AC signal waveform. There are three types of fixed waveforms (sine, square, and triangle waves), and you can store up to 16 user-defined arbitrary waveforms.

● FUNC setting

CV/CC mode	Input type	Factory default setting	Notes
CV and CC	 Sine wave  Square wave  Triangle wave ARB1 to ARB16 are user-defined arbitrary waveforms	 Sine wave	Use remote control (USER command) to set user-defined arbitrary waveforms. See Communication Interface Manual

[See](#) p. 172

● User-defined arbitrary waveforms

You can store up to 16 user-defined arbitrary waveforms in ARB1 to ARB16. The following are the initial waveforms that are stored on the PBZ as part of the factory default settings. The amplitude of these initial waveforms is the rated value of each PBZ model.

- Ramp (ARB1 and ARB2)
- Exponential function (ARB3 and ARB4)
- Half-wave rectification (ARB5 and ARB6)
- Full-wave rectification (ARB7 and ARB8)
- Half-period sine wave (ARB9 and ARB10)
- Step response (from ARB 11 to ARB13)
- Impulse response (from ARB14 to ARB16)

AMPL

Use the AMPL setting to set the voltage amplification in CV mode and the current amplification in CC mode. You can invert the output of AC signals. To invert the output, set the AMPL setting to a negative value. Use the rotary knob or the numeric keys to enter the value for the AMPL setting. Use the numeric keys to enter the value's sign (-).

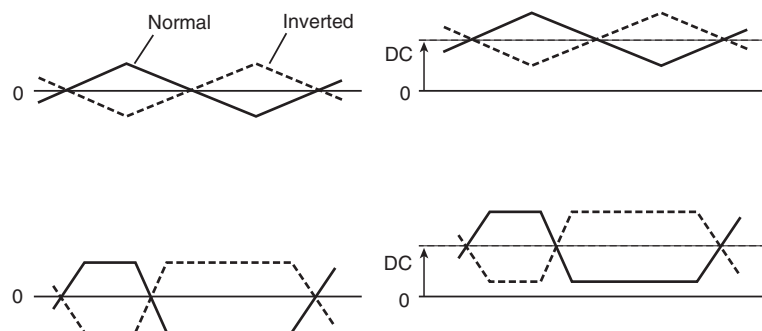

● To enter the AMPL value and sign using the numeric keys

1 Use the cursor keys to move the cursor to AMPL.

2 Press NUM.

The NUM key illuminates, and you can use the numeric keys to enter values. To stop using the numeric keys, press NUM again (the NUM key turns off).

3 Use the +/-, number, and decimal point keys to specify the number.

The number that you specify is displayed. For positive values, the sign (+) is not displayed. You cannot specify a number that exceeds the input range. If you attempt to do so, a buzzer will sound.

If you specify an incorrect number, press NUM (the NUM key turns off). Next, press NUM again, and specify the correct number.

Each time you press +/-, the sign switches between positive (+) and negative (-). If you only use the number keys to specify a number, the sign is positive (+).

4 Press ENTER to enter the number.

The NUM key turns off. Lesser significant digits that are not entered are set to zero. If you only use the +/- key to specify the AMPL value, it is set to 0.0.

● Input range of the AMPL setting

Bipolar mode

	CV (Factory default setting: 0 Vpp)		CC (Factory default setting: 0 App)	
	Input range	Resolution	Input range	Resolution
PBZ20-20	-42.00 Vpp to +42.00 Vpp	0.01 V	-42.00 App to +42.00 App	0.01 A
PBZ40-10	-84.0 Vpp to +84.0 Vpp	0.1 V	-21.00 App to +21.00 App	0.01 A
PBZ60-6.7	-126.0 Vpp to +126.0 Vpp	0.1 V	-14.07 App to +14.07 App	0.01 A
PBZ80-5	-168.0 Vpp to +168.0 Vpp	0.1 V	-10.50 App to +10.50 App	0.01 A

Unipolar mode

	CV (Factory default setting: 0 Vpp)		CC (Factory default setting: 0 App)	
	Input range	Resolution	Input range	Resolution
PBZ20-20	-21.00 Vpp to +21.00 Vpp	0.01 V	-42.00 App to +42.00 App	0.01 A
PBZ40-10	-42.0 Vpp to +42.0 Vpp	0.1 V	-21.00 App to +21.00 App	0.01 A
PBZ60-6.7	-63.0 Vpp to +63.0 Vpp	0.1 V	-14.07 App to +14.07 App	0.01 A
PBZ80-5	-84.0 Vpp to +84.0 Vpp	0.1 V	-10.50 App to +10.50 App	0.01 A

■ Limit of the input range based on the rating

If an AC signal is superimposed (AC ON) on a DC signal (the DC setting + FINE setting), the settable range is limited based on the PBZ's rated values, which differ between bipolar and unipolar modes. However, if the sum of the DC setting, the FINE setting, and the AMPL setting exceeds the rated value, the following occur:

- If the DC setting was entered first, it takes precedence. Otherwise, the AMPL setting takes precedence. Whichever setting is entered at a later time, it is limited based on the setting that was entered first.
- If you use the rotary knob to enter the number, the numbers change up to the input limit.
- If you enter a number that exceeds the input limit using the numeric keys, it will be changed to the limit.

● **Input range limits**

	AC ON	AC OFF
DC+FINE	The sum of the DC setting, the FINE setting, and the AMPL setting must be within the rated value.	The entire input range
AMPL		The entire input range

● **Setup example: CV mode and bipolar mode (PBZ20-20)**

Signal source	Setting	Value
DC signal	DC setting	+14 V
AC signal	FUNC	~ Sine wave
	AMPL	+2 Vp-p

The maximum amplitude ($V_{\text{swing-p}}$) is 15 V on the positive side. The margin between the maximum amplitude and the rated value (the maximum settable voltage on the positive side) is 6 V (21 V - 15 V). If you set the AC signal again, its maximum amplitude is 14 Vp-p.

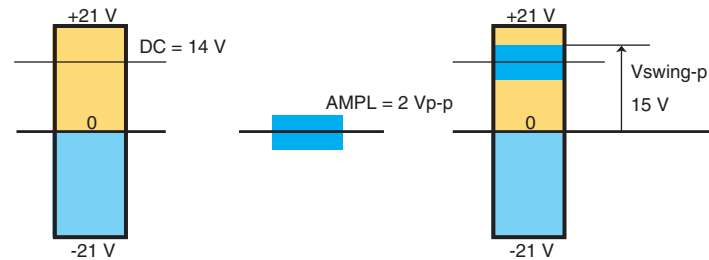

FREQ

Use the FREQ setting to set the AC signal frequency.

● **Input range of the FREQ setting**

CV/CC mode	Input range	Resolution	Factory default setting	Frequency response ¹	
				PBZ20-20/ PBZ60-6.7/ PBZ80-5	PBZ40-10
CV	0.01 Hz to 100.00 kHz	0.01 Hz	1000 Hz	DC to 100 kHz	DC to 100 kHz
CC	0.01 Hz to 100.00 kHz	0.01 Hz	1000 Hz	DC to 10 kHz	DC to 5 kHz

¹-3dB. The frequency response values are typical values at an ambient temperature of 23 °C.

AC ON/OFF

Use the AC ON/OFF setting to turn the AC signal on and off.

● **Input range of the AC ON/OFF setting**

CV/CC mode	Input range	Factory default setting
CV and CC	ON or OFF	OFF

Start Phase and Square Wave Signal Duty Ratio (Page 2/5)

The PBZ uses the values that you specify for the settings that are explained in this section in both bipolar mode and unipolar mode. The settable ranges are the same for both bipolar mode and unipolar mode.

PHASE

See p. 89 , p. 150

Use the PHASE setting to set the AC signal start phase. If you have used **CONFIG** to set OPERATION (synchronous operation) to SYNC SLAVE or SYNC SLAVE END, you cannot set the start phase while the output is turned on (you can set it while the output is turned off).

● Input range of the PHASE setting

CV/CC mode	Input range	Resolution	Factory default setting
CV and CC	FREE (not specified)	–	0 deg
	0 deg to 359 deg	1 deg	

DUTY

Use the DUTY setting to set the square wave signal duty ratio. You can specify this setting when the AC signal waveform is set to .

$$\text{DUTY} = t / T (\%)$$

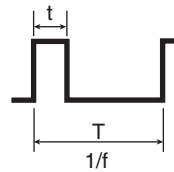

● Input range of the DUTY setting

CV/CC mode	Signal frequency f	Input range	Resolution	Factory default setting
CV and CC	$f < 100 \text{ Hz}$	0.1 to 99.9 %	0.1 %	50 %
	$100 \text{ Hz} \leq f < 1 \text{ kHz}$	1 to 99 %	1 %	
	$1 \text{ kHz} \leq f < 10 \text{ kHz}$	10 to 90 %	10 %	
	$10 \text{ kHz} \leq f$	50 % (fixed)	–	

Frequency Sweep Mode and Time (Page 3/5)

The PBZ uses the values that you specify for the settings that are explained in this section in both bipolar mode and unipolar mode. The settable ranges are the same for both bipolar mode and unipolar mode.

SWEEP

Use the SWEEP setting to set whether or not the PBZ executes sweeps.

● Input range of the SWEEP setting

CV/CC mode	Input range	Factory default setting
CV	OFF or ON	OFF
CC		

OFF: Sweeps are not executed. ON: Sweeps are executed.

If SWEEP is set to OFF, the frequency is the value that is specified for the FREQ setting.

If you have used **CONFIG** to set OPERATION (synchronous operation) to SYNC MASTER, SYNC SLAVE, or SYNC SLAVE END, you cannot set SWEEP to ON (execute sweeps).

See p. 89

MODE

Use the MODE setting to set the sweep mode.

● Input range of the MODE setting

CV/CC mode	Input range	Factory default setting
CV	LOG or LINEAR	LINEAR
CC		

LOG: Logarithmic sweep (the frequency changes logarithmically).

LINEAR: Linear sweep (the frequency changes linearly).

TIME

Use TIME to set the sweep time.

● Input range of the TIME setting

CV/CC mode	Input range	Resolution	Factory default setting
CV	0.1 ms to 1000.0000 s	0.1 ms	1 s
CC			

Start and Stop Frequencies of the Frequency Sweep (Page 4/5)

The PBZ uses the values that you specify for the settings that are explained in this section in both bipolar mode and unipolar mode. The settable ranges are the same for both bipolar mode and unipolar mode.

START and STOP

Use the START and STOP settings to set the start and stop frequencies. These settings are unrelated to the FREQ setting.

● Input range of the START and STOP settings

CV/CC mode	Input range	Resolution	Factory default setting
CV	0.01 Hz to 100.00 kHz	0.01 Hz	1
CC	0.01 Hz to 100.00 kHz	0.01 Hz	

¹START: 100 Hz. STOP: 1000 Hz.

The TRIG OUT Terminal's Function, and the Marker Frequency of the Frequency Sweep (Page 5/5)

The PBZ uses the values that you specify for the settings that are explained in this section in both bipolar mode and unipolar mode. The settable ranges are the same for both bipolar mode and unipolar mode.

TRIG OUT

Use the TRIG OUT setting to set the function of the TRIG OUT terminal. Select from not generating output, generating AC signal synchronization signals, or generating frequency marker signals. AC signal synchronization signals are generated when the internal signal source's AC signal is turned on. Frequency marker signals are generated when the frequency sweep is turned on.

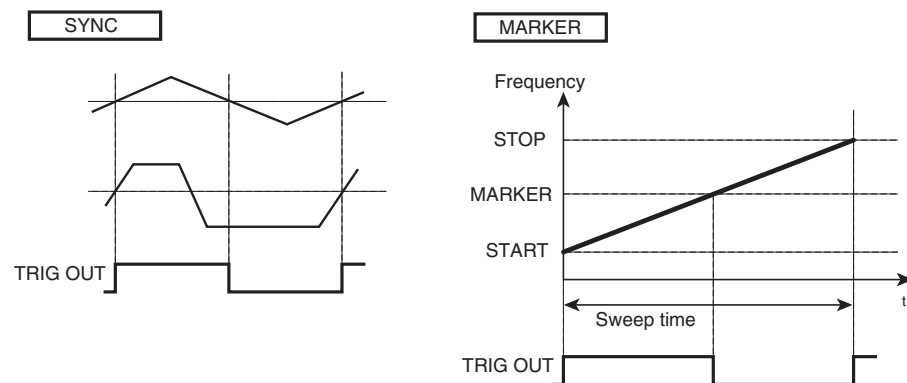

● Input range of the TRIG OUT setting

CV/CC mode	Input range	Factory default setting
CV	OFF, SYNC, or MARKER	OFF
CC		

- OFF: No signal is generated.
- SYNC: AC signal synchronization signals are generated (the duty ratio is fixed to 50 %).
- MARKER: Frequency marker signals are generated.

See p. 89

You can only set TRIG OUT to SYNC (generate AC signal synchronization signals) if you have used **CONFIG** to set OPERATION (synchronous operation) to SYNC SLAVE END. If OPERATION (synchronous operation) is set to SYNC MASTER, SYNC SLAVE, or SYNC SLAVE END, you cannot set TRIG OUT to MARKER (generate frequency marker signals).

MARKER FREQ

Use the MARKER FREQ setting to set the marker frequency. The marker frequency can be set to a value between the specified start frequency and stop frequency. If you set the marker frequency to a value that is close to the start or stop frequency, the marker frequency will actually be set to a value that is slightly larger than the start frequency or slightly smaller than the stop frequency, respectively.

The factory default setting is 500.00 Hz.

Using External Control Signals

You can control the DC signal by using voltages that are from 0 V to approximately ± 10 V or by using 10 k Ω variable resistors. Before using this function, you have to use **CONFIG** to change some settings. In the figure below, control voltage or variable resistors are indicated as “Control signal J1.” Pressing the DC and AC keys will have no effect.

See p. 87

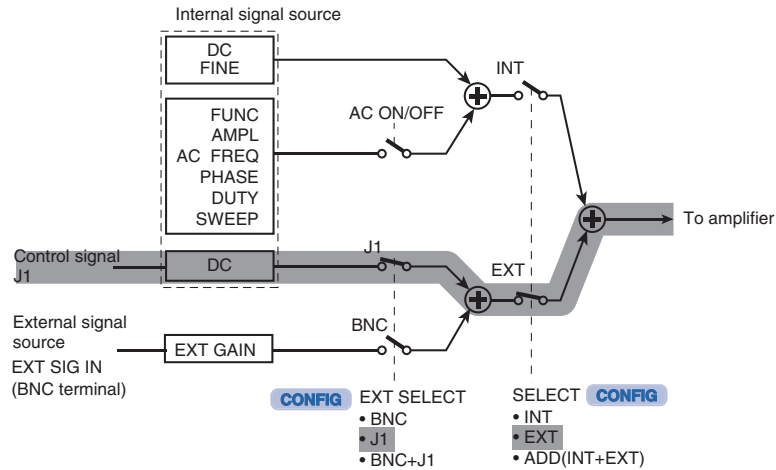

Using External Voltage (Control Signal J1)

You can control the internal signal source's DC signal by using external voltage that is from 0 V to approximately ± 10 V. In CV mode, you can control the voltage. In CC mode, you can control the current. The output is equal to the sum of the setting that is determined by the external voltage (control signal J1) and the DC values that are set from the panel and remote control.

Connecting an external voltage

Connect an external voltage (V_{ext}) as shown in the following figure.

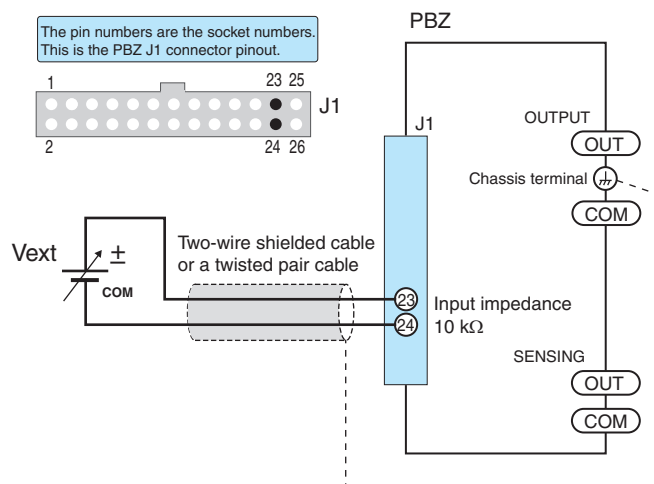

CAUTION • Do not apply a voltage of 10.5 V or greater across the external voltage control pins. Doing so could damage the PBZ.

Connect a low-noise, stable voltage source to Vext. To reduce the influence of noise on the output, connect a two-wire shielded cable or a twisted pair cable across Vext, and connect the voltage source so that it is as close to the PBZ as possible. If the wiring between the PBZ and the voltage source is long, it becomes easy for noise to influence the operation of the PBZ. Even if you use wires that are designed to suppress noise, the PBZ may not operate properly.

The relationship between the external voltage and the output

The control range differs between bipolar and unipolar modes.

● Bipolar mode

	CV		CC	
	External voltage (Vext)	Output	External voltage (Vext)	Output
PBZ20-20	Approx. -10 V to Approx. +10 V	-20 V to +20 V	Approx. -10 V to Approx. +10 V	-20 A to +20 A
PBZ40-10		-40 V to +40 V		-10 A to +10 A
PBZ60-6.7		-60 V to +60 V		-6.7 A to +6.7 A
PBZ80-5		-80 V to +80 V		-5 A to +5 A

● Unipolar mode

	CV		CC	
	External voltage (Vext)	Output	External voltage (Vext)	Output
PBZ20-20	Approx. 0 V to Approx. +10 V	0 V to +20 V	Approx. -10 V to Approx. +10 V	-20 A to +20 A
PBZ40-10		0 V to +40 V		-10 A to +10 A
PBZ60-6.7		0 V to +60 V		-6.7 A to +6.7 A
PBZ80-5		0 V to +80 V		-5 A to +5 A

● CV mode

The relationship between the external voltage (Vext), the rated output voltage (Ertg), and the output voltage (Eo) is shown in the following equation:

$$E_o = E_{rtg} \times V_{ext}/10$$

	PBZ20-20	PBZ40-10	PBZ60-6.7	PBZ80-5
Ertg	20	40	60	80

● CC mode

The relationship between the external voltage (Vext), the rated output current (Irtg), and the output current (Io) is shown in the following equation:

$$I_o = I_{rtg} \times V_{ext}/10$$

	PBZ20-20	PBZ40-10	PBZ60-6.7	PBZ80-5
Irtg	20	10	6.7	5

Example: PBZ20-20 in CV mode

Output voltage $E_o = (20 \times 2/10) + 3 + 4 = 11 \text{ V}$

Setting	Value
Ertg	20 V
Vext	2 V
DC signal that is set from the panel settings	3 V
DC signal that is set from remote control	4 V

Using External Resistance

You can control the internal signal source's DC signal by changing the reference voltage's voltage-divider ratio through the use of external variable resistors. In CV mode, you can control the voltage. In CC mode, you can control the current. The output is equal to the sum of the value that is determined by the external resistance and the DC values that are set from the panel and remote control.

Connecting an external resistor

Connect an external resistor (R_{ext}) as shown in the following figure. The arrow represents the wiper.

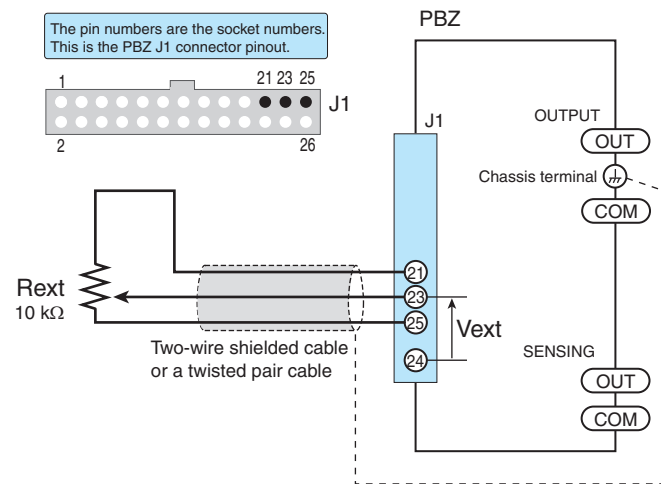

NOTE

- If you are switching between fixed resistors to control the PBZ, use a short-circuit type or continuous-type switch.

For R_{ext} , use a resistor that is rated at approximately $10\text{ k}\Omega$, $1/2\text{ W}$ or greater, that has a low temperature coefficient, and that will change little over time. Examples of such resistors are metal film or wire wound resistors. To reduce the influence of noise on the output, connect a two-wire shielded cable or a twisted pair cable across R_{ext} , and connect the resistor so that it is as close to the PBZ as possible. If the wiring between the PBZ and the resistor is long, it becomes easy for noise to influence the operation of the PBZ. Even if you use wires that are designed to suppress noise, the PBZ may not operate properly.

The relationship between the external resistance and the output

The voltage across the wiper that is in contact with the external resistance and J1 pin 24 is V_{ext} , which is used to control the voltage. The relationship between V_{ext} and the output is the same as when you are using an external voltage.

See p. 53

Using the EXT SIG IN Signal (External Signal Source)

This makes the PBZ into a bipolar amplifier that amplifies the input signal that is applied to EXT SIG IN (the BNC terminal). You can set the gain, the polarity (inverted or not inverted), and the offset of the amplifier. Pressing the DC and AC keys that are used to set the internal signal source will have no effect.

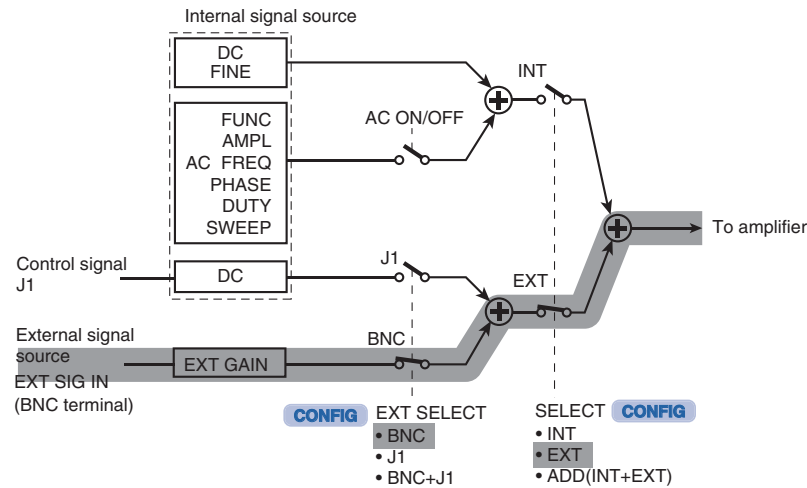

Input terminal specifications

Item	Specification
Maximum allowable input voltage	± 12 V _{peak}
Input impedance	Approx. 10 k Ω
Common terminal	Connected to the OUTPUT COM terminal

Gain Setting

Configure the amplifier by specifying the gain using a value and the polarity (inverted or not inverted) by specifying the sign (positive or negative). The absolute value of the specified value is the gain. If the sign is positive, the polarity is not inverted. If the sign is negative, the polarity is inverted.

See p. 87

Use **CONFIG** to set the gain and the polarity (inverted or not inverted) of the amplifier.

● Input range of the gain setting

	CV(Gain) ¹		CC (Conductance) ²	
	Input range	Resolution	Input range	Resolution
PBZ20-20	-20.00 V/V to +20.00 V/V	0.01 V/V	-20.00 A/V to +20.00 A/V	0.01 A/V
PBZ40-10	-40.0 V/V to +40.0 V/V	0.1 V/V	-10.00 A/V to +10.00 A/V	0.01 A/V
PBZ60-6.7	-60.0 V/V to +60.0 V/V	0.1 V/V	-6.70 A/V to +6.70 A/V	0.01 A/V
PBZ80-5	-80.0 V/V to +80.0 V/V	0.1 V/V	-5.00 A/V to +5.00 A/V	0.01 A/V

¹Factory default setting: 0 V/V

²Factory default setting: 0 A/V

● CV mode

Output voltage = external signal input voltage \times \pm gain (in units of V/V)

● **CC mode**

Output current = external signal input voltage × ±conductance (in units of A/V)

Example: PBZ20-20 in CV mode

Output voltage $E_o = 20 \times 0.7 = 14 \text{ V}$

Setting	Value
Gain	+20 V/V
External signal source voltage	0.7 V

Offset Setting

See p. 87

The offset setting adds a DC signal to the input signal and sets the offset of the DC component. There are the following two ways that you can specify the offset setting. Use

CONFIG to specify the signal source that will be used as the offset.

- By combining the signal that is applied to EXT SIG IN and an external control signal (applied to J1).
- By combining the signal that is applied to EXT SIG IN and the internal signal source (DC).

■ Combining the signal that is applied to EXT SIG IN and an external control signal (applied to J1)

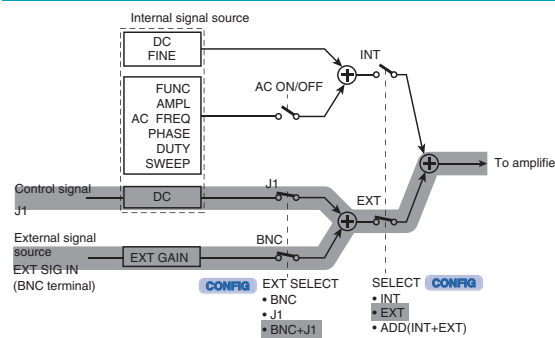

When the offset is specified, the internal signal source's DC signal that is controlled by the control signal (applied to J1) is added to the input signal.

See

For the setup procedure, see "Using External Voltage (Control Signal J1)" on page 52 and "Using External Resistance" on page 54.

■ Combining the signal that is applied to EXT SIG IN and the internal signal source (DC)

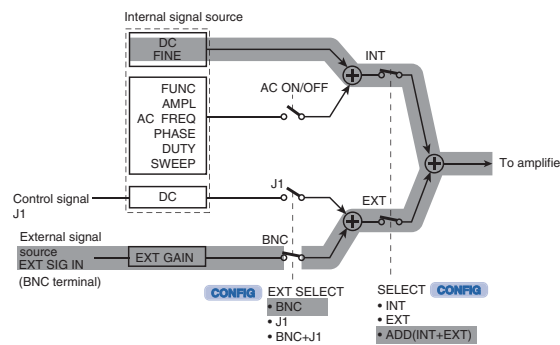

When the offset is specified, the internal signal source's DC signal (DC) is added to the input signal.

See

For the setup procedure, see "Selecting the DC Signal (Internal Signal Source)" on page 40. Turn the internal signal source's AC signal off. For the setup procedure, see "Turning AC Signals On and Off (AC ON/OFF)" on page 44.

Turning Output On and Off and using Soft Start and Soft Stop

You can turn output on and off immediately by using the switch or control signals. You can also use the soft start and soft stop features so that the PBZ gradually increases or decreases the output, respectively.

For details of the output impedance when the output is on/off, see “Appendix”.

 p. 173

Turning the Output On and Off Immediately

You can turn the output on and off immediately (without using the soft start and soft stop features) by:

- Using the OUTPUT key.
- Synchronizing the output with the POWER switch.
- Using an input signal applied to the external contact.

 p. 89 , p. 147

If multiple PBZs are synchronized, you can turn on and off the output of all synchronized PBZs by turning the output on and off on the master unit.

You can only turn output on and off if you have used **CONFIG** to set OPERATION (synchronous operation) to SYNC MASTER. If OPERATION (synchronous operation) is set to SYNC SLAVE or SYNC SLAVE END, you can only turn the output off.

Using the OUTPUT key

1 Press OUTPUT.

The OUTPUT LED illuminates. The output is turned on, and it is generated at the current setting.

2 Press OUTPUT again.

The OUTPUT LED turns off. The output is turned off.

NOTE

If the output is off because of the input signal applied to the external contact, even if you press the OUTPUT key, the output will not turn on.

Synchronizing the output with the POWER switch

 p. 87

This feature turns the output on at the same time that the POWER switch is turned on. In the factory default settings, output remains off when the POWER switch is turned on.

Use **CONFIG** to set this feature.

CAUTION

If you change the load, it may be damaged if the PBZ's OVP and OCP settings are not correct. For details, see “Protection Features and Alarms” on page 64.

Using an input signal applied to the external contact

Apply an input signal to the rear panel J1 connector's OUTPUT ON/OFF terminal to turn the output on and off.

Use **CONFIG** to set this feature.

Output	Input signal
ON	On the rising edge from low to high
OFF	Low ¹

¹In this condition, pressing OUTPUT will have no effect.

The Output Soft Start and Soft Stop Features

When the PBZ is using the soft start feature, the output rises from zero to the DC setting when output is turned on. The time that the PBZ takes to raise the output is the soft start time. When the PBZ is using the soft stop feature, the output decreases from the DC setting to zero when output is turned off. The time that the PBZ takes to decrease the output is the soft stop time.

You can only specify the soft start and soft stop times for the DC setting. If you press the OUTPUT key while the PBZ is executing a soft start or soft stop, the process is canceled and the output is turned off.

Normal operation

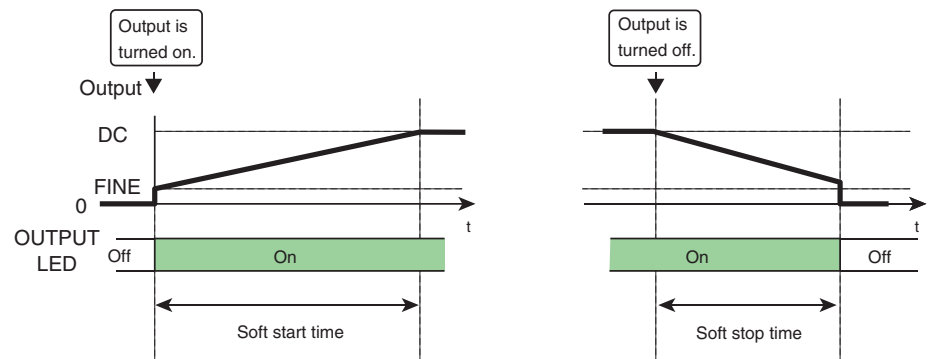

When the OUTPUT key is pressed during soft start or soft stop

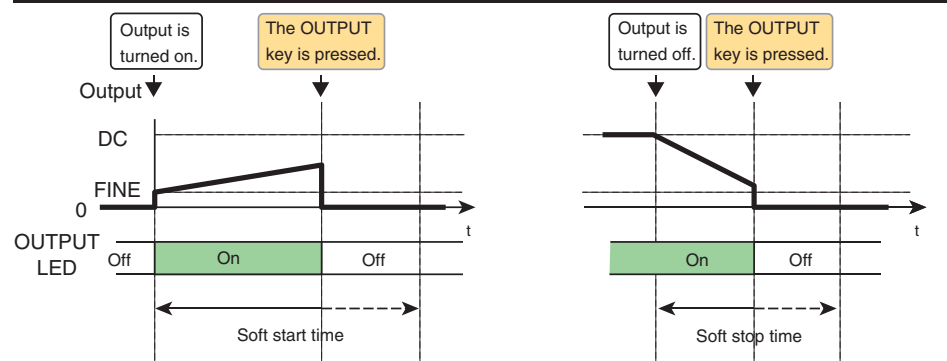

● **When a soft start begins:**

- The OUTPUT LED illuminates.
- The remaining soft start time is displayed.
- The current DC setting is displayed.

● **If you press the OUTPUT key while the PBZ is executing a soft start**

The soft start is canceled, the output is turned off, and the OUTPUT LED turns off.

● **When a soft stop begins:**

- The OUTPUT LED remains on. It turns off when the soft stop completes.
- The remaining soft stop time is displayed.
- The current DC setting is displayed.

● **If you press the OUTPUT key while the PBZ is executing a soft stop**

The soft stop is canceled, the output is turned off, and the OUTPUT LED turns off.

Measurement Feature and Current Monitor Output

Measurement range

Setting		Measurement range	Resolution
Voltage measurement	DC	±120 % of rtg	0.001 V
	AC	120 % of rtg/CF	
	DC+AC	120 % of rtg	0.01 V
	PEAK	±120 % of rtg	
Current measurement	DC	±120 % of rtg	0.001 A
	AC	120 % of rtg/CF	
	DC+AC	120 % of rtg	0.01 A
	PEAK	±120 % of rtg	

- If a measured value exceeds the upper limit of the measurement range, “+OVER” is displayed for the value. If a measured value falls below the lower limit of the measurement range, “-OVER” is displayed for the value. If a measured value exceeds the measurement range upper limit and another value falls below the lower limit, “±OVER” is displayed for the value.
- CF is the crest factor. (Crest factor = the maximum value/the actual value)
As the crest factor becomes large, the AC RMS measurement range becomes small.

Measured points

The PBZ measures the OUTPUT terminal’s voltage and current, and displays the results. When remote sensing is enabled, the voltage measurement point is the sensing terminal’s connection point.

See p. 86

Use **CONFIG** to set the items that enable remote sensing.

Measured value display

DC measurement

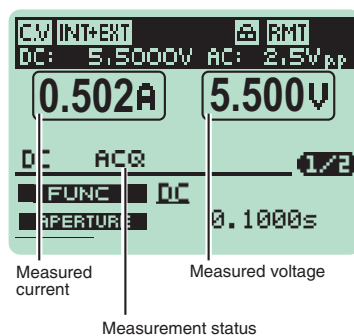

PEAK measurement

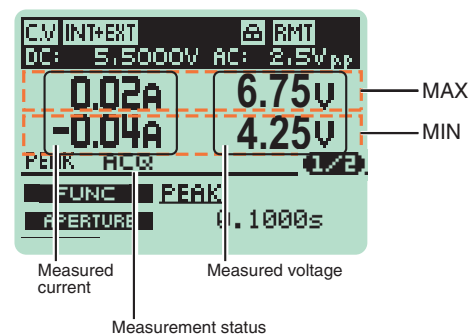

Measurement status display

The measurement status is indicated. If the measurement status display is blinking, the PBZ is performing the measurement function indicated here.

- ACQ (acquire): The PBZ is performing measurements (measurement time). When the measurement time completes, the measured value display is updated.
- TRIG (trigger): The PBZ is waiting for a trigger.
- DELAY: The PBZ is waiting for the specified delay time.

Measurement Feature Settings



- 1 Press MEASURE.**
The MEASURE key illuminates, and the MEASURE setup screen (1/2) appears. The cursor is displayed at the FUNC value.
- 2 Press MEASURE to select the page that you want to edit.**
The page switches.
- 3 Use the up and down cursor keys to select a setting.**
The cursor moves to the setting that you want to specify. You can switch the page by continuously pressing the up or down cursor key.
- 4 To enter a number, use the left and right cursor keys to move the cursor to the digit that you want to specify.**
This operation is unnecessary if you are using the numeric keys.
- 5 Use the rotary knob or numeric keys to specify the value.**
If you fix the value that you specified using the rotary knob, the input value is confirmed. If you are using the numeric keys to specify the value, press ENTER to confirm the input value.
- 6 To specify other settings, return to step Procedure 2.**
- 7 To set up other features, press a key other than MEASURE.**
The MEASURE key turns off. The measurement setup completes, and the PBZ switches to the feature for the key that you pressed.

See p. 71

Measurement Feature and Measurement Time (Page 1/2)

FUNC

Input range	Description	Factory default setting
DC	Direct current	DC
AC	AC RMS (AC coupling)	
DC+AC	DC + AC RMS (DC coupling)	
	True RMS value of (DC + AC RMS) = $\sqrt{DC^2 + AC^2}$	
PEAK	Maximum (MAX) and minimum (MIN)	

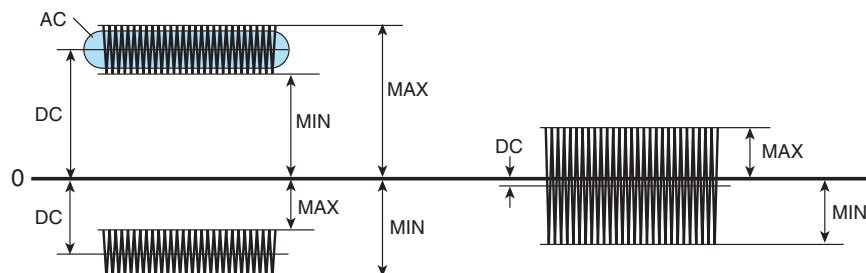

APERTURE

Use APERTURE to set the measurement time.

Input range	Resolution	Factory default setting
0.0001 s to 3600.0000 s	0.1 ms	0.1 s

With a longer measurement time, the measurements become more stable, but it takes longer to update the display of the measured values. Guidelines for the measurement time when the signal includes an AC component are given below.

- When the period of the AC is known, you can obtain the most accurate measurement results if you set the measurement time to an integer multiple of the period.
Example: If the period of the AC component is 10 s, you can obtain the best results in the shortest time if you set the measurement time to 10 s.
- When the period of the AC component is unknown, you can obtain comparatively stable measurement results if you set the measurement time to a value that is at least 10 times the expected period.

Measurement Start Trigger and Delay (Page 2/2)

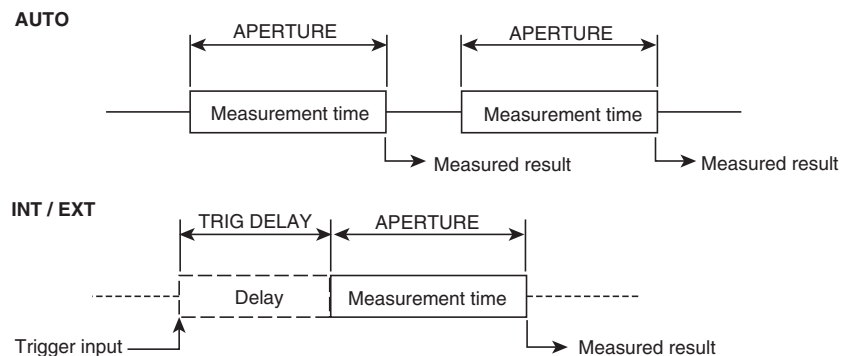

TRIG SOURCE

Use the TRIG SOURCE setting to set the measurement start conditions.

Input range	Description	Factory default setting
AUTO	The PBZ automatically takes repeated measurements.	AUTO
INT	The PBZ starts measurement when any of the following output settings are changed: DC (DC signal) AC ON/OFF (AC signal on/off state) FUNC (AC signal waveform) AMPL (AC signal amplification) FREQ (AC signal frequency) PHASE (AC signal phase)	
EXT↑	The PBZ starts measurement when a rising (↑) edge is detected in the TRIG IN input signal.	
EXT↓	The PBZ starts measurement when a falling (↓) edge is detected in the TRIG IN input signal.	

TRIG DELAY

If the trigger source is set to INT or EXT, you can set the delay between when the start conditions are met and the measurement actually begins.

Input range	Resolution	Factory default setting
0.00000 s to 3600.00000 s	0.01 ms	0 s

Current Monitor Output

The front panel I MON terminal (BNC terminal) generates a voltage that is proportional to the output current.

Specifications of the current monitor output terminal

Item	Specification
Output voltage	± 2 V at the rated current
Frequency response	DC to 20 kHz (-3 dB)
Common terminal	Connected to the OUTPUT COM terminal

In parallel operation, the master unit generates a voltage that is proportional to the total output current (the sum of the currents produced by all units operating in parallel). The slave units generate voltages that are proportional to their own output currents.

Protection Features and Alarms

Protection Feature Types

Overvoltage and overcurrent protection

These protection features are activated when the PBZ detects an output voltage or output current that is greater than or equal to the protection activation point. You can use both the overvoltage and overcurrent protection features in three different modes. You can set different protection activation points in the positive and negative directions. The protection feature uses the output terminals to perform detection.

Mode	What is detected	Action
Overvoltage protection	OVP (OUTPUT-OFF)	Output is turned off (the POWER switch remains on).
	OVP (POWER-OFF)	After the output is turned off, the POWER switch is turned off.
	V.LIM (Voltage limit)	The output voltage is limited to a value just below the protection activation point.
Overcurrent protection	OCP (OUTPUT-OFF)	Output is turned off (the POWER switch remains on).
	OCP (POWER-OFF)	After the output is turned off, the POWER switch is turned off.
	I.LIM (Current limit)	The output current is limited to a value just below the protection activation point.

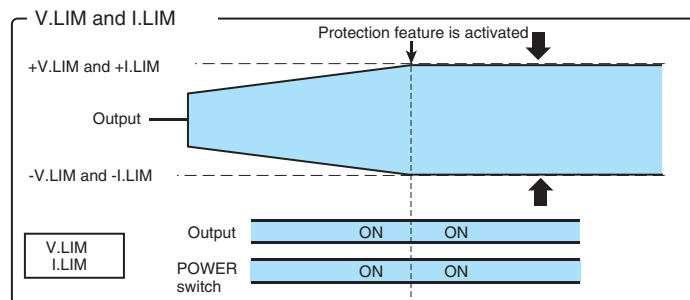
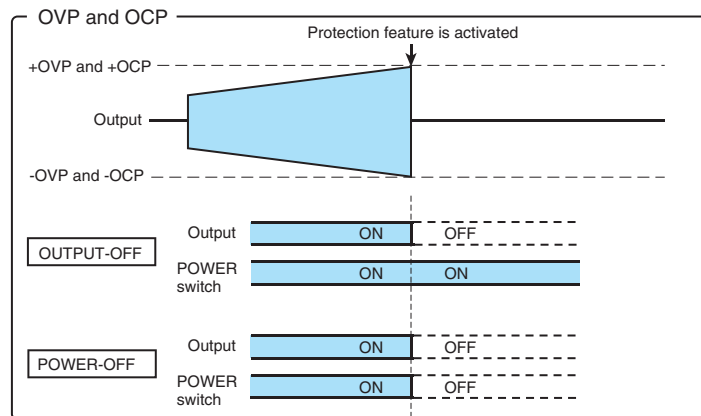

- **Even when V.LIM (the voltage limit) is selected, OVP is enabled.**

This OVP (hereafter referred to as “120 % OVP”) is enabled with positive and negative activation points that are approximately 120 % of the rated value (fixed) even when V.LIM (the voltage limit) is selected. Unlike other OVPs, the activation points of 120 % OVP cannot be changed.

You cannot set the overvoltage protection mode to V.LIM (the voltage limit) and OVP at the same time. However, 120 % OVP is a special feature that is always enabled even if you do not select it.

120 % OVP operates in the presence of short-term, transient changes that cannot be limited by V.LIM (the voltage limit). The 120 % OVP mode is the same as the mode that you have specified with OVP/OCP ACTION (OUT OFF or POW OFF).

- **Response speed of V.LIM (the voltage limit) and I.LIM (the current limit)**

The response speed of V.LIM (the voltage limit) is interlocked with the CV mode voltage response setting. The response speed of I.LIM (the current limit) is interlocked with the CC mode current response setting.

When you are using the PBZ in CV mode, set the CC mode current response setting to set the I.LIM (the current limit) response speed. When you are using the PBZ in CC mode, set the CV mode voltage response setting to set the V.LIM (the voltage limit) response speed.

The OVP and OCP operations are independent of the CV mode voltage response setting and the CC mode current response setting.

Overheat protection (OHP)

This protection feature is activated when the PBZ’s internal temperature rises to an abnormal level. The output is turned off.

OHP protects the PBZ from the following situations.

- When the PBZ is used in an environment that exceeds its operating ambient temperature range.
- When the PBZ is used in a location that does not provide adequate space around its inlet and vent holes.

Power limit (sink power)

If you connect a device to the OUTPUT terminal that can supply power, like a battery, the PBZ is a load to the device. In this situation, there is a limit to the amount of power that the PBZ can consume. When the PBZ’s sink power becomes too large, it limits its output current (the sink current to the PBZ) so that the sink power reduces to a constant value.

	Sink power ¹			
	PBZ20-20	PBZ40-10	PBZ60-6.7	PBZ80-5
Bipolar mode	100 W	180 W	200 W	200 W
Unipolar mode	400 W	400 W	402 W	400 W

¹The sink power values are typical values at an ambient temperature of 23 °C.







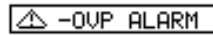

Parallel operation protection

During parallel operation, the output is turned off when an alarm is detected in a slave unit or when a slave unit turns off.

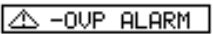
Alarm Feature

An alarm sounds when any of the following protection features are activated. The alarm does not sound if the V.LIM or I.LIM protection feature is activated.

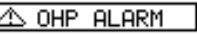
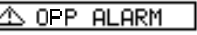
- OVP
- OCP
- OHP
- OPP
- 120 % OVP
- Parallel operation protection

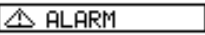
Protection feature	Alarm generation ¹	Alarm displayed on the screen
Overvoltage protection	OVP (OUTPUT-OFF)	+OVP:  +OVP ALARM
	OVP (POWER-OFF)	The voltage exceeded the positive voltage activation point. -OVP ² :  -OVP ALARM The voltage exceeded the negative voltage activation point.
Overvoltage protection	V.LIM (Voltage limit)	No  p. 67
	120 % OVP (OUTPUT-OFF)	+OVP:  +OVP ALARM The voltage exceeded the positive voltage activation point.
	120 % OVP (POWER-OFF)	-OVP ² :  -OVP ALARM The voltage exceeded the negative voltage activation point.
Overcurrent protection	OCP (OUTPUT-OFF)	+OCP:  +OCP ALARM
	OCP (POWER-OFF)	The current exceeded the positive current activation point. -OCP:  -OCP ALARM The current exceeded the negative current activation point.
	I.LIM (Current limit)	No  p. 67
Overheat protection	OHP	OHP:  OHP ALARM
Power limit	P-LIMIT	OPP:  OPP ALARM  p. 67
Parallel operation protection	Yes (buzzer)	 ALARM The alarm is detected in a slave unit.

¹An ALARM SIGNAL is transmitted from the J1 connector.

²In unipolar mode, -OVP does not function.

Clearing alarms

- When an alarm is activated, press the ALM CLR (SHIFT + PROT) key.
If the POWER switch does not turn off even though an alarm has been activated, the alarm will be activated again unless you eliminate the cause of the alarm.
- If the alarm activation caused the POWER switch to turn off, first eliminate the cause of the alarm, and then turn the POWER switch back on.
- If the cause of the alarm was overheat protection (OHP), you cannot turn the output back on until the PBZ's internal temperature lowers to a safe level. If you press OUTPUT, the overheat protection (OHP) will be activated again.

If an alarm still occurs even after you have corrected all the causes of alarms, the PBZ may be malfunctioning. Stop using it immediately, and contact your Kikusui agent or distributor.

State Display of the Limit Features

When the voltage V.LIM protection, the current I.LIM protection, or the power limit (internal loss) protection is activated, the limit state display shows which protection feature has been activated.

Protection feature	Display	An example where all the limit features are displayed
Voltage limit	V.LIM	+V.LIM: The voltage was limited by the positive voltage activation point. -V.LIM: The voltage was limited by the negative voltage activation point.
Current limit	I.LIM	+I.LIM: The current was limited by the positive current activation point. -I.LIM: The current was limited by the negative current activation point.
Power limit	P-LIMIT	P.LIM: The power was limited by the sink power activation point.

How to Set and Check Activation Points

Mode and selectable items

Mode		CURR and VOLT (selection)	OVP/OCP ACTION (selection)	OVP, OCP, and LIMIT (numerical setting)
Overvoltage protection	OVP (OUTPUT-OFF)	OVP	OUT OFF	+OVP
	OVP (POWER-OFF)		POW OFF	-OVP
	V.LIM	LIMIT	None	+V.LIM -V.LIM
Overcurrent protection	OCP (OUTPUT-OFF)	OCP	OUT OFF	+OCP
	OCP (POWER-OFF)		POW OFF	-OCP
	I.LIM	LIMIT	None	+I.LIM -I.LIM

Activation points

Screen page	Setting	Description	Settable range (resolution) ¹			
			PBZ20-20	PBZ40-10	PBZ60-6.7	PBZ80-5
[1/3]	+I.LIM +OCP	Positive (+) Current activation point.	+0.20 A to <u>+22.00 A</u> (0.01 A)	+0.10 A to <u>+11.00 A</u> (0.01 A)	+0.06 A to <u>+7.37 A</u> (0.01 A)	+0.05 A to <u>+5.50 A</u> (0.01 A)
	-I.LIM -OCP	Negative (-) Current activation point.	-0.20 A to <u>-22.00 A</u> (0.01 A)	-0.10 A to <u>-11.00 A</u> (0.01 A)	-0.06 A to <u>-7.37 A</u> (0.01 A)	-0.05 A to <u>-5.50 A</u> (0.01 A)
[2/3]	+V.LIM ²	Positive (+) Voltage limit activation point.	-22.00 V to <u>+22.00 V</u> (0.01 V)	-44.00 V to <u>+44.00 V</u> (0.01 V)	-66.00 V to <u>+66.00 V</u> (0.01 V)	-88.00 V to <u>+88.00 V</u> (0.01 V)
	+OVP	Positive (+) OVP activation point.	+0.20 V to <u>+22.00 V</u> (0.01 V)	+0.40 V to <u>+44.00 V</u> (0.01 V)	+0.60 V to <u>+66.00 V</u> (0.01 V)	+0.80 V to <u>+88.00 V</u> (0.01 V)
	-V.LIM ²	Negative (-) Voltage limit activation point.	-22.00 V to <u>+22.00 V</u> (0.01 V)	-44.00 V to <u>+44.00 V</u> (0.01 V)	-66.00 V to <u>+66.00 V</u> (0.01 V)	-88.00 V to <u>+88.00 V</u> (0.01 V)
	-OVP ³	Negative (-) OVP activation point.	-0.20 V to <u>-22.00 V</u> (0.01 V)	-0.40 V to <u>-44.00 V</u> (0.01 V)	-0.60 V to <u>-66.00 V</u> (0.01 V)	-0.80 V to <u>-88.00 V</u> (0.01 V)
	[3/3]	CURR	Overcurrent protection feature.	<u>LIMIT</u> or OCP		
	VOLT	Overvoltage protection feature.	<u>LIMIT</u> or OVP			
	OCP/ OVP ACTION	The protective action that is carried out when OVP or OCP is activated.	<u>OUT OFF</u> or POW OFF			

¹Underlined values are factory default settings.

²-V.LIM ≤ +V.LIM, In unipolar mode, the lower limit of the settable range is -1 % of rated voltage or more.

³Cannot be set when the PBZ is in unipolar mode.

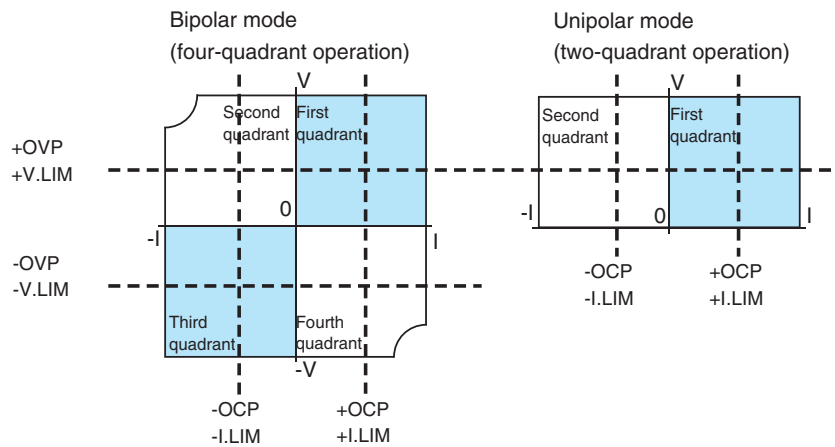

NOTE

You can specify the protection settings even when the output is on. The protection settings take effect immediately after you set them. If the output voltage or output current exceeds the new protection settings that you have specified, the protection features will activate.

1 Press PROT.

The PROT key illuminates, and the PROT setup screen (1/3) appears.

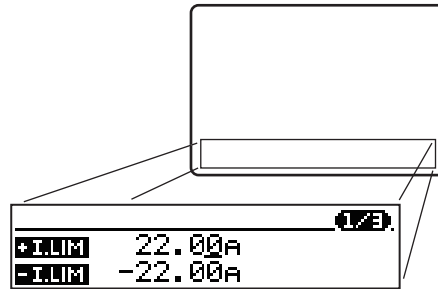

The display differs depending on the CURR and VOLT selections that are made on page 3/3. In the figure above, LIMIT has been selected for both CURR and VOLT.

2 Press PROT to select the page that contains the item you want to set.

There are three pages (the figure below shows page 3/3).



If you are just checking the settings, check the items on both pages, and proceed to step Procedure 6.

3 Use the up and down cursor keys to select a setting.

The cursor moves to the value. You can switch the page by continuously pressing the up or down cursor key.

4 Use the rotary knob or numeric keys to specify the value.

If you fix the value that you specified using the rotary knob, the input value is confirmed. If you are using the numeric keys to specify the value, press ENTER to confirm the input value.

5 To specify other settings, repeat steps Procedure 2 to 4.**6 To set up other features, press a key other than PROT.**

The PROT key turns off. The protection feature setup completes, and the PBZ switches to the feature for the key that you pressed.

See p. 71

Basic Operations

Selecting Settings

The settings are separated across multiple menu pages. First switch to the menu page that has the setting that you want to specify, and then use the cursor to select the setting.
Example: Press MEASURE.

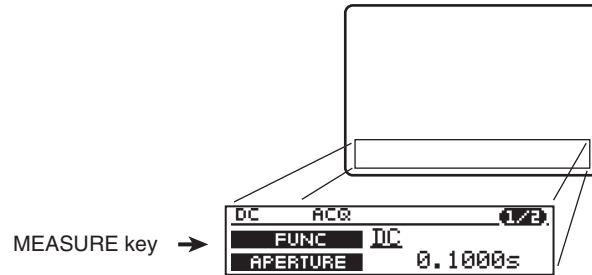

Example: Press AC and then switch between the menu pages (page 1/5 to page 5/5).

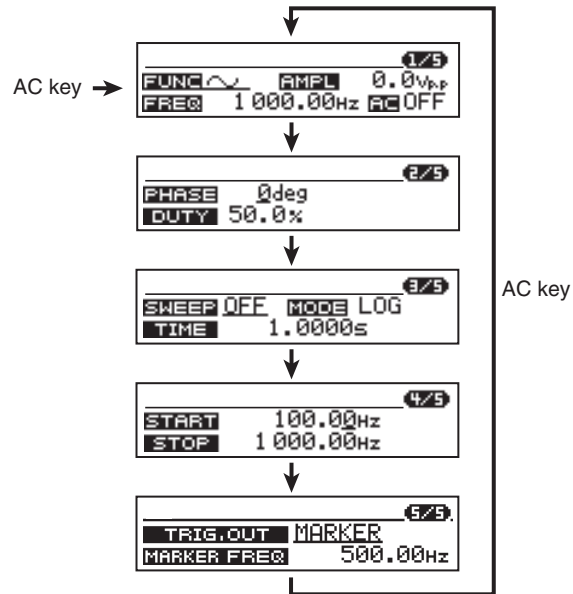

Using the CONFIG Key

See p. 85

The CONFIG key and the corresponding menus are used to set the PBZ's basic operation conditions and system configuration. They are used to set a variety of settings that aren't shown on the front panel. The settings are separated across multiple menu pages. First switch to the menu page that has the setting that you want to specify, and then use the cursor to select the setting.

Example: Press CONFIG to display menu page 1/7.

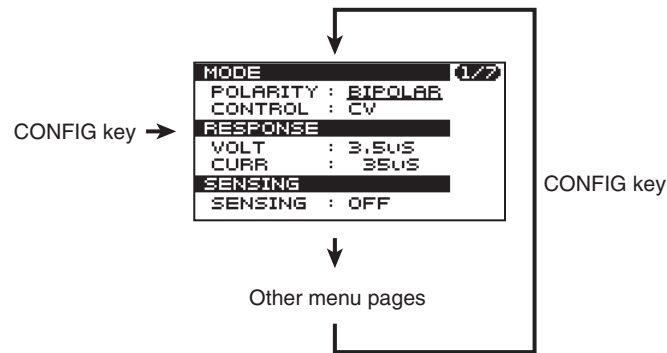

Using the Cursor Keys

Cursor keys are used to move the cursor around the screen.

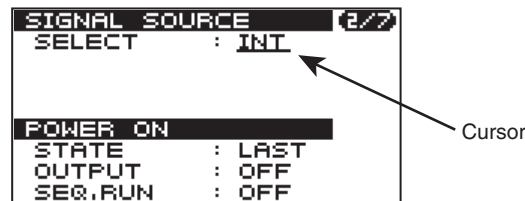

Operation	Cursor position	What happens on the PBZ
Press the up cursor key	The top line on the screen	The previous page is displayed. If the current page is the first page, the last page is displayed.
Press the up and down cursor keys	Anywhere except for the top or bottom line on the screen	The cursor moves on the screen. (These keys are used to select a setting.)
Press the down cursor key	The bottom line on the screen	The next page is displayed. If the current page is the last page, the first page is displayed.
Press the left and right cursor keys	Anywhere on the screen	The cursor moves on the screen. (These keys are used to select a setting and to change the digit when specifying a number.)

Using the Rotary Knob

The rotary knob is used to enter values and to select settings. To specify numbers, use the left and right cursor keys to select the digit, and then turn the rotary knob to change the value.

Operation	What happens on the PBZ
Turn clockwise	The number increases. (If you fix the input, the number is set to the value shown.)
Turn counterclockwise	The number decreases. (If you fix the input, the number is set to the value shown.)

Using the Numeric Keys

- 1 Press NUM.**
 The NUM key illuminates, and you can use the numeric keys to enter values. To stop using the numeric keys, press NUM again (the NUM key turns off).
- 2 Use the number and decimal point keys to specify the number.**
 You cannot specify a number that exceeds the input range. If you attempt to do so, a buzzer will sound. If you specify an incorrect number, press the left cursor key to delete the number and re-specify it. You can also press NUM (the NUM key turns off), and start again from Procedure 1.
- 3 Press k (kilo), m (milli), or ENTER to enter the number.**
 The NUM key turns off. Lesser significant digits that are not entered are set to zero. If you enter a number that is outside of the settable range, the lowest significant digit is rounded in order to set the value to a number within the settable range. When you finish entering values with the numeric keys, the PBZ switches from numeric-key input mode to rotary-knob input mode.

Using the SHIFT Key

While holding down SHIFT, press another key that is written in blue on the panel.

Operation	What happens on the PBZ
Press the SHIFT key	While holding down the SHIFT key, the following keys (written in blue on the panel) are enabled: <ul style="list-style-type: none"> •AC ON/OFF •ALM CLR •KEYLOCK •EDIT •STORE •ABC STORE

Prohibiting Key Operations (Key Lock)

The PBZ has three levels of key locks. Use **CONFIG** to set the level.

See p. 90

Operation	What happens on the PBZ
Hold KEY LOCK (SHIFT + LOCAL) down to lock the keys.	A buzzer sounds, and the KEYLOCK icon is displayed on the screen.
Hold KEY LOCK (SHIFT + LOCAL) down while the keys are locked (to unlock the keys).	A buzzer sounds, and the KEYLOCK icon is cleared from the screen.

Changing the Screen Brightness

You can select from 11 brightness levels.
Hold the SHIFT key down, and turn the rotary knob.

Operation	What happens on the PBZ
Turn clockwise	The contrast increases.
Turn counterclockwise	The contrast decreases.

Setting the PBZ to Local Mode

Use the following operation to finish remote control and enable key operations (the RMT icon in the status display area is cleared).

Operation	What happens on the PBZ
Press LOCAL	Remote control finishes.

Setting the PBZ to Its Factory Default Settings

Use the following operation to set the PBZ to its factory default settings.

Operation	What happens on the PBZ
While holding down SHIFT, turn the POWER switch on.	"INITIALIZING" is displayed on the screen, and the PBZ is initialized to its factory default settings.

Buzzer

The buzzer sounds when the following operations are carried out, or when the PBZ is in one of the following states. Use **CONFIG** to turn the buzzer sound on and off.

 p. 90

Operation or state	What happens on the PBZ	Notes
Turn the POWER switch on and off	Two short, high-pitched sounds	When the PBZ starts or shuts down.
Selftest error at startup	Three long, high-pitched sounds	System error
Overvoltage, overcurrent, or overheat	A single long, high-pitched sound	This is the alarm noise.
Lock or unlock the key lock	A single short, high-pitched sound	Operation accepted.
Communication command or key input error	A single short, low-pitched sound	Operation rejected.

This page is intentionally blank.





3

Memory, Response, and Configuration

This chapter explains preset memory, setup memory, response, and configuration.

Memory Types

The PBZ is equipped with both preset and setup memory.

Differences between Preset and Setup Memory

Item	Preset memory	Setup memory
Number of memory entries	3 in CV mode and 3 in CC mode.	10 (independent of the CV/CC mode setting).
Memory number	A, B, or C.	0 to 9.
Memory naming	Not allowed.	15 characters maximum.
CV/CC mode	Limited to the mode that the PBZ is currently in. ¹	No limitations. ²
Bipolar/unipolar mode	No limitations in bipolar mode. In unipolar mode, negative DC signals that were saved in bipolar mode cannot be loaded. ³	No limitations. ⁴
Signal source	Internal signal sources.	Internal signal sources.
Saved settings	Settings for DC and AC signals.	Settings for DC and AC signals, preset memory, overvoltage and overcurrent protection features, and configuration.
When output is turned on	Memory entries can be saved or loaded.	Memory entries can be saved but not loaded.
When output is turned off	Memory entries can be saved or loaded.	Memory entries can be saved or loaded.

¹The CV/CC mode setting is not saved. You can only load memory numbers that were saved in the same mode as the mode that the PBZ is currently in.

²The CV/CC mode setting is saved. When a memory number is loaded, the PBZ switches to the mode that is specified in the memory entry.

³The bipolar/unipolar mode setting is not saved.

⁴The bipolar/unipolar mode setting is saved. When a memory number is loaded, the PBZ switches to the mode that is specified in the memory entry.

Primary Usage

Preset memory

You can save settings that are used often in preset memory. There are three memory entries for CV mode and three memory entries for CC mode (A, B, and C in each mode). Because you can load saved settings just by pressing a key, this feature is very useful when you want to switch between three different types of output in order.

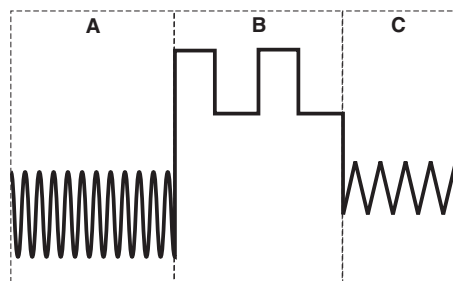

Setup memory

You can use setup memory to save all of the basic PBZ settings. You can load the contents of a memory entry when output is turned off. Check the contents of the memory entry on the screen, and turn output on again.

Preset Memory

You can save and load preset memory entries regardless of whether the output is on or off. You can save up to three sets of settings to memory entries A, B, and C in each CV/CC mode (CV and CC). Only the settings for the internal signal source are saved. The settings that are saved are shown in the following table.

Saved setting			Factory default setting ¹
DC signal (CV or CC mode)	DC	Voltage or current	0 V or 0 A
	FINE	Fine adjustment of the DC setting	0 V or 0 A
AC signal (CV or CC mode)	ON/OFF	AC signal on/off state	OFF ²
	FUNC	Waveform	~ Sine wave ²
	AMPL	Amplitude	0 V or 0 A
	FREQ	Frequency	1000 Hz ²
	PHASE	Start phase	0 deg ²
	DUTY	Square wave duty ratio	50 % ²

¹The same in all three memory entries (A, B, and C).

²The same in both CV and CC mode.

If you use **CONFIG** to change settings to DEFAULT (the default values), memory is not affected. If you reset the PBZ to its factory default settings, all the memory entries are cleared. (This manual differentiates between the terms “default values” and “factory default settings.”)

NOTE

- In unipolar mode, you cannot load negative DC signals that were saved in bipolar mode.
- The protection features' activation points are not saved. If the settings that you load cause protection features' activation points to be exceeded, an alarm will occur.

Saving Settings to Preset Memory

1 Press ABC STORE (SHIFT + C).

The A, B, and C keys blink. The settings that will be saved are displayed on the screen. To abort the save operation, proceed to Procedure 3.

```
PRESET STORE
DC : 5.000V
FINE : 0.5000V
AC : ON
FUNC : ~
AMPL : 5.0V-P
FREQ : 1000.00Hz
PHASE : FREE
```

2 Press A, B, or C.

The settings are saved to the preset memory entry. The key that corresponds to the saved memory entry (A, B, or C) illuminates.

■ Aborting the save operation

3 Press ABC STORE (SHIFT + C) again.

The A, B, and C keys turn off, the DC key illuminates, and the DC signal setup screen is displayed.

Loading Preset Memory Entries

See p. 90

You can load preset memory entries in two ways. Use **CONFIG** to specify which method to use.

- **1KEY**

Preset memory entries are loaded as soon as you press the A, B, or C key.

- **2KEY**

After you press the A, B, or C key, the contents of the preset memory entry are displayed on the screen for you to confirm. The preset memory entry is loaded when you press the ENTER key.

1KEY

1 Press A, B, or C.

The selected key illuminates, and the contents of the selected preset memory entry are loaded. You cannot abort the load operation.

2KEY

1 Press A, B, or C.

The selected key blinks. The contents of the preset memory entry that will be loaded are displayed on the screen. To load a different preset memory entry, press a different preset memory key. To abort the load operation, proceed to Procedure 3.

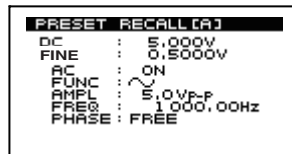

2 Press ENTER.

The selected key illuminates, and the contents of the selected preset memory entry are loaded.

■ Aborting the load operation

3 Press the key that is blinking.

The selected key turns off, the DC key illuminates, and the DC signal setup screen is displayed.

NOTE

The A, B, or C key that corresponds to the loaded preset memory entry illuminates. When one of these keys is illuminated, it means that the panel settings are those of the loaded preset memory entry. If you change any of the settings, the illuminated preset memory key turns off.

Setup Memory

You can save and load setup memory entries regardless of whether the output is on or off, but you can only load entries when output is off. You can save up to 10 sets of settings in memory numbers 0 to 9. You can assign a name to each memory entry. Names can be a maximum of 15 characters in length. The settings that are saved are shown in the following table.

If you use **CONFIG** to change settings to DEFAULT (the default values), memory is not affected. If you reset the PBZ to its factory default settings, all the memory entries are cleared. (This manual differentiates between the terms “default values” and “factory default settings.”)

Saved setting		Factory default setting ¹
DC signal	DC	Voltage or current
	FINE	Fine adjustment of the DC setting
	SOFT START	Soft start time
	SOFT STOP	Soft stop time
AC signal	ON/OFF	AC signal on/off state
	FUNC	Waveform
	AMPL	Amplitude
	FREQ	Frequency
	PHASE	Start phase
	DUTY	Square wave duty ratio
	AC signal sweep	SWEEP
Frequency sweep	MODE	Sweep mode
	TIME	Sweep time
	START	Start frequency
	STOP	Stop frequency
	MARKER FREQ	Marker frequency
	TRIG OUT	TRIG OUT terminal: on/off
	Overvoltage protection	+V.LIM and +OVP
-V.LIM and -OVP		Negative overvoltage protection activation point
LIMIT / OVP		Mode
Overcurrent protection	+I.LIM and +OCP	Positive overcurrent protection activation point
	-I.LIM and -OCP	Negative overcurrent protection activation point
	LIMIT / OCP	Mode
The protective action that is carried out when OVP or OCP is activated		Power off or output off
Preset memory	A, B, and C memory entries for CV mode A, B, and C memory entries for CC mode	A, B, and C memory entries for CV mode
MEASURE	FUNC	DC
	APERTURE	0.1 s
	TRIG SOURCE	AUTO
	TRIG DELAY	0 s
CONFIG settings	MODE	
	RESPONSE	
	SENSING	
	SIGNAL SOURCE	
	POWER ON	The same as the CONFIG factory default settings
	SYNCHRONOUS	
	TRIGGER	
	EXT OUTPUT ON/OFF	 p. 86
	MEMORY	
	KEYLOCK	
	BEEP	
PARALLEL		

¹The same for memory numbers 0 to 9. Each memory entry name is UNTITLED.

Saving Settings to Setup Memory

- 1 Press STORE (SHIFT + RECALL).**
The STORE (SHIFT + RECALL) key blinks, and the cursor is displayed at the memory number. Because no memory number is selected, "NO SELECT" is displayed. To abort the save operation, press a key other than the STORE (SHIFT + RECALL) key.
- 2 Turn the rotary knob to select a memory number (from STO0 to STO9).**
The name of the memory entry that corresponds to the selected memory number is displayed. If no name has been assigned to the memory entry, "UNTITLED" is displayed.
- 3 Use the left and right cursor keys to select the character that you want to change.**
If you do not want to change the character, proceed to Procedure 8.
- 4 Turn the rotary knob to select the character.**
You can select ASCII code characters in the range of 0x20 to 0x7E. If you fix the character that you specified using the rotary knob, the character is confirmed. To add or delete characters, proceed to the following steps.

Adding and deleting characters

- 5 Use the left and right cursor keys to select a character.**
- 6 Press INS (SHIFT + the up cursor key).**
A space is inserted to the left of the cursor.
If you press DEL (SHIFT + the down cursor key), the character at the cursor position is deleted.
- 7 Turn the rotary knob to select the character.**
The space changes to the selected character. You can select ASCII code characters in the range of 0x20 to 0x7E. You can enter up to 15 characters. If you want to continue entering characters, repeat steps Procedure 5 to Procedure 7. If you want to finish entering characters, proceed to the next step.
- 8 Press ENTER.**
The STORE (SHIFT + RECALL) key turns off. "Saved!" is briefly displayed, and the settings are saved to the selected memory number. If a memory entry already exists with the same memory number, it is overwritten.

Loading Setup Memory Entries

- 1 Press OUTPUT to turn output off.**
- 2 Press RECALL.**
The RECALL key blinks, and the memory number and memory name are displayed. To abort the load operation, press the RECALL key again.
- 3 Turn the rotary knob to select a memory number (from RCL0 to RCL9).**
The memory name that corresponds to the selected memory number is displayed.
- 4 Press ENTER.**
The RECALL key turns off. "Recalled!" is briefly displayed, and the settings that correspond to the selected memory number are loaded.

Response Setting

See p. 27

Under certain conditions, such as when you select square waves for the signal source or when there is a large amount of inductance in the load wiring, the output waveform may be distorted or oscillation may occur. In these situations, you can reduce oscillation and the distortion of the output waveform by setting responses (rise and fall times). You can set four levels of responses in both CV and CC mode (as explained below). The PBZ provides its fastest responses when it is set to the factory default settings.

Setting Procedure

See p. 86

Generally, the output waveform is distorted or oscillation occurs when the PBZ is in CV mode and is connected to a load that with capacitance and when the PBZ is in CC mode and is connected to a load with inductance. After connecting the actual load to the PBZ, select the appropriate response from the four response levels that provides the most stable response.

Use **CONFIG** to set the responses. The selectable values are the rise and fall times for rated loads. Rise and fall times are affected by the load impedance.

CONFIG setting	Description	Value	Actual value	Factory default setting
RESPONSE >VOLT	CV mode Voltage response	3.5 US	3.5 μs	3.5 US
		10 US	10 μs	
		35 US	35 μs	
		100 US	100 μs	
RESPONSE >CURR (PBZ20-20/ PBZ60-6.7/ PBZ80-5)	CC mode Current response	35 US	35 μs	35 US
		100 US	100 μs	
		350 US	350 μs	
		1 ms	1 ms	
RESPONSE >CURR (PBZ40-10)	CC mode Current response	70 US	70 μs	70 US
		100 US	100 μs	
		350 US	350 μs	
		1 ms	1 ms	

- **Influence on the response speed of V.LIM (the voltage limit) and I.LIM (the current limit)**

See p. 64

The response speed of V.LIM (the voltage limit) is interlocked with the CV mode voltage response setting. The response speed of I.LIM (the current limit) is interlocked with the CC mode current response setting.

When you are using the PBZ in CV mode, set the CC mode current response setting to set the I.LIM (the current limit) response speed. When you are using the PBZ in CC mode, set the CV mode voltage response setting to set the V.LIM (the voltage limit) response speed.

Examples of Responses

The following figures show typical responses.

CV mode (output open)

3.5 μ s

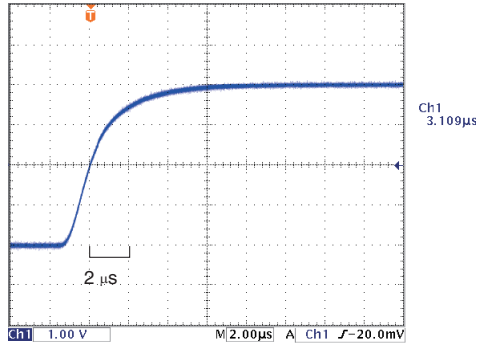

35 μ s

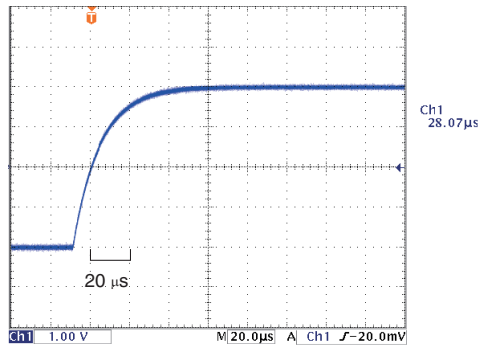

CC mode (output shorted)

35 μ s

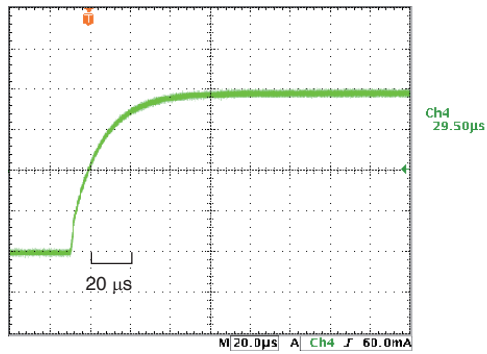

350 μ s

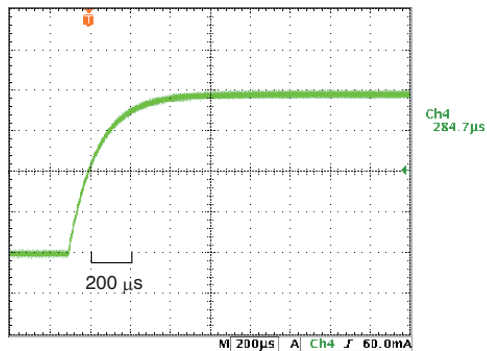

Load Resistance and Frequency Responses

In CC mode, the frequency responses are affected by the load resistance. The frequency responses that are listed in the specifications were taken when the PBZ was connected to a rated load.

	PBZ20-20	PBZ40-10	PBZ60-6.7	PBZ80-5
Rated load	1 Ω	4 Ω	9 Ω	16 Ω

When the load resistance is higher than the rated load, the cutoff frequency is lower than the value that is listed in the specifications. On the other hand, when the load resistance is lower than the rated load, the cutoff frequency is higher than the value that is listed in the specifications.

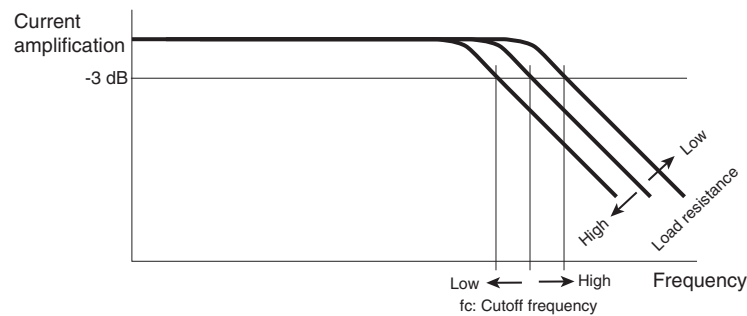

$$f_c = \frac{R_{Lrtg}}{R_L} \times f_{crtg} \quad \text{---- (1)}$$

f_{crtg} : Cutoff frequency when the PBZ is connected to a rated load
 R_{Lrtg} : Rated load
 R_L : Load resistance

● The relationship between the response settings, the load resistance, and the cutoff frequency

When a rated load R_{Lrtg} is connected to the PBZ, the cutoff frequency f_{crtg} depends on the response setting as shown in the following table. If a load resistance other than the rated load is connected to the PBZ, the cutoff frequency f_c is calculated for each response setting as shown in equation (1) in the figure above. If you lower the load resistance, the cutoff frequency increases. When the output is shorted, the cutoff frequency may exceed four times that when the PBZ is connected to a rated load.

	Response setting	Cutoff frequency f_{crtg}
PBZ20-20 (Rated load R_{Lrtg} : 1 Ω)	35 μs	10 kHz
	100 μs	3.5 kHz
	350 μs	1 kHz
PBZ60-6.7 (Rated load R_{Lrtg} : 9 Ω)	1 ms	350 Hz
	70 μs	5 kHz
	100 μs	3.5 kHz
PBZ80-5 (Rated load R_{Lrtg} : 16 Ω)	350 μs	1 kHz
	1 ms	350 Hz

An equivalent circuit for CC mode output is shown in the figure below. The cutoff frequency depends on the output capacitance and the load resistance as expressed by equation (2).

CC mode output equivalent circuit

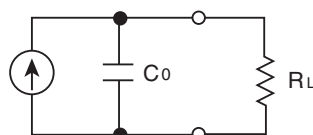

$$f_c = \frac{1}{2\pi C_0 R_L} \quad \text{---- (2)}$$

C_0 : Output capacitance
 R_L : Load resistance

Configuration (CONFIG)

List of CONFIG Settings

See p. 86

The settings explained here are used to set the PBZ's basic operation conditions and system configuration. You can specify and view settings on the CONFIG screens. For detailed information about each setting, see "CONFIG Setting Details".

CONFIG-	Setting		Description	
[1]	MODE	POLARITY	Bipolar/unipolar mode	
		CONTROL	CV/CC mode	
	RESPONSE	VOLT	Voltage response	
		CURR	Current response	
	SENSING		Remote sensing	
[2]	SIGNAL SOURCE	SELECT	Signal source	
		EXT SELECT	External signal source	
		EXT GAIN	External signal circuit gain	
	POWER ON	STATE	Power-on state	
		OUTPUT	Power-on output state	
SEQ RUN		Power-on sequence execution		
[3]	SYNCHRONOUS	OPERATION	Synchronous operation	
	TRIGGER	TRIG IN	Polarity of the trigger signal input	
		TRIG OUT	Polarity of the trigger signal output	
	EXT OUTPUT ON/OFF	POLARITY	Contact signal logic to turn the output on through external control	
[4]	MEMORY RECALL	PRESET	Method used to load preset memory entries	
	KEY LOCK	LEVEL	The keys that are locked	
	BEEP		Buzzer sound on or off	
[5]	PARALLEL ¹	OPERATION	Master or slave unit in parallel operation	
		UNIT	Number of units in parallel operation	
[6]	ERR TRACE		SCPI error display	
	INTERFACE TYPE ^{*1}		Remote interface selection	
	GPIB ^{*1}	ADDRESS		GPIB address
		RS232C ^{*1}	BAUDRATE	Baud rate
			DATA BITS	Data bits
			STOP BITS	Stop bits
			PARITY BIT	Parity bit
			X-FLOW	Flow control
	USB		VENDOR ID	Vendor ID
			PRODUCT ID	Product ID
			SERIALNo.	Serial number
	LAN ^{*1, 2}		DHCP	DHCP feature
			AUTO IP	Automatic IP address assignment
		STATUS	LAN status display	
		IP ADDR	IP address display	
		SUBNET	Subnet mask display	
		MAC	MAC address display	
[7]	MODEL INFO	MODEL	Model name display	
		SERIAL No.	Serial number display	
		VERSION	Firmware version display	

¹The setting do not take effect until you restart the PBZ.

²Only when the factory option LAN interface is installed.

Setting and Viewing CONFIG Settings

1 Press CONFIG.

The CONFIG key illuminates, and the CONFIG setup screen (CONFIG[1]) appears.

```

MODE (1/7)
POLARITY : BIPOLAR
CONTROL  : CV
RESPONSE
VOLT     : 3.5US
CURR     : 35US
SENSING
SENSING  : OFF
  
```

2 Press CONFIG to select the page that contains the item you want to set.

The CONFIG setup screen has seven pages, from CONFIG[1] to CONFIG[7].

If you are just checking the settings, check the items on all the pages, and proceed to step Procedure 6.

3 Use the up and down cursor keys to select a setting.

The cursor moves to the value. You can switch the page by continuously pressing the up or down cursor key.

```

SIGNAL SOURCE (2/7)
SELECT       : INT
POWER ON
STATE       : LAST
OUTPUT      : OFF
SEQ.RUN     : OFF
  
```

Cursor

4 Use the rotary knob or numeric keys to specify the value.

If you fix the value that you specified using the rotary knob, the input value is confirmed. If you are using the numeric keys to specify the value, press ENTER to confirm the input value.

5 To specify other settings, repeat steps Procedure 2 to 4.

6 To set up other features, press a key other than CONFIG.

The CONFIG key turns off. The CONFIG setup completes, and the PBZ switches to the feature for the key that you pressed.

7 If you have changed parallel operation or remote interface settings, turn the power switch off and then on again.

The settings are applied.

See p. 72

CONFIG Setting Details

CONFIG[1]: Mode, Response, and Remote Sensing

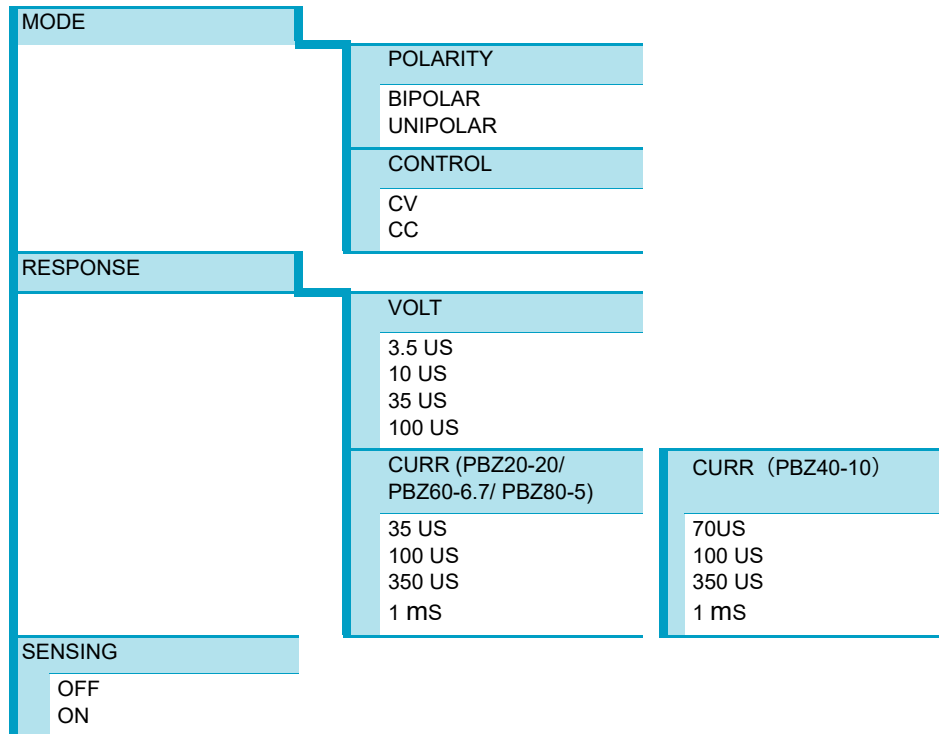

Item	Description	Value	Actual value	Factory default setting
MODE >POLARITY	Bipolar/unipolar mode	BIPOLAR	Bipolar mode	BIPOLAR
		UNIPOLAR	Unipolar mode	
MODE >CONTROL	CV/CC mode	CV	CV mode	CV
		CC	CC mode	
RESPONSE >VOLT	CV mode Voltage response	3.5 US	3.5 μ s	3.5 US
		10 US	10 μ s	
		35 US	35 μ s	
		100 US	100 μ s	
RESPONSE >CURR (PBZ20-20/ PBZ60-6.7/ PBZ80-5)	CC mode Current response	35 US	35 μ s	35 US
		100 US	100 μ s	
		350 US	350 μ s	
		1 ms	1 ms	
RESPONSE >CURR (PBZ40-10)	CC mode Current response	70 US	70 μ s	70 US
		100 US	100 μ s	
		350 US	350 μ s	
		1 ms	1 ms	
SENSING	Remote sensing feature	OFF	Disables the remote sensing feature	OFF
		ON	Enables the remote sensing feature	

NOTE

- The PBZ does not change automatically from CV mode to CC mode.
- You cannot change the following settings when the output is on.
 - CONFIG[1]>MODE>POLARITY
 - CONFIG[1]>MODE>CONTROL
 - CONFIG[1]>MODE>SENSING

CONFIG[2]: Signal Source, External Signal Circuit Gain, and the Power-On State

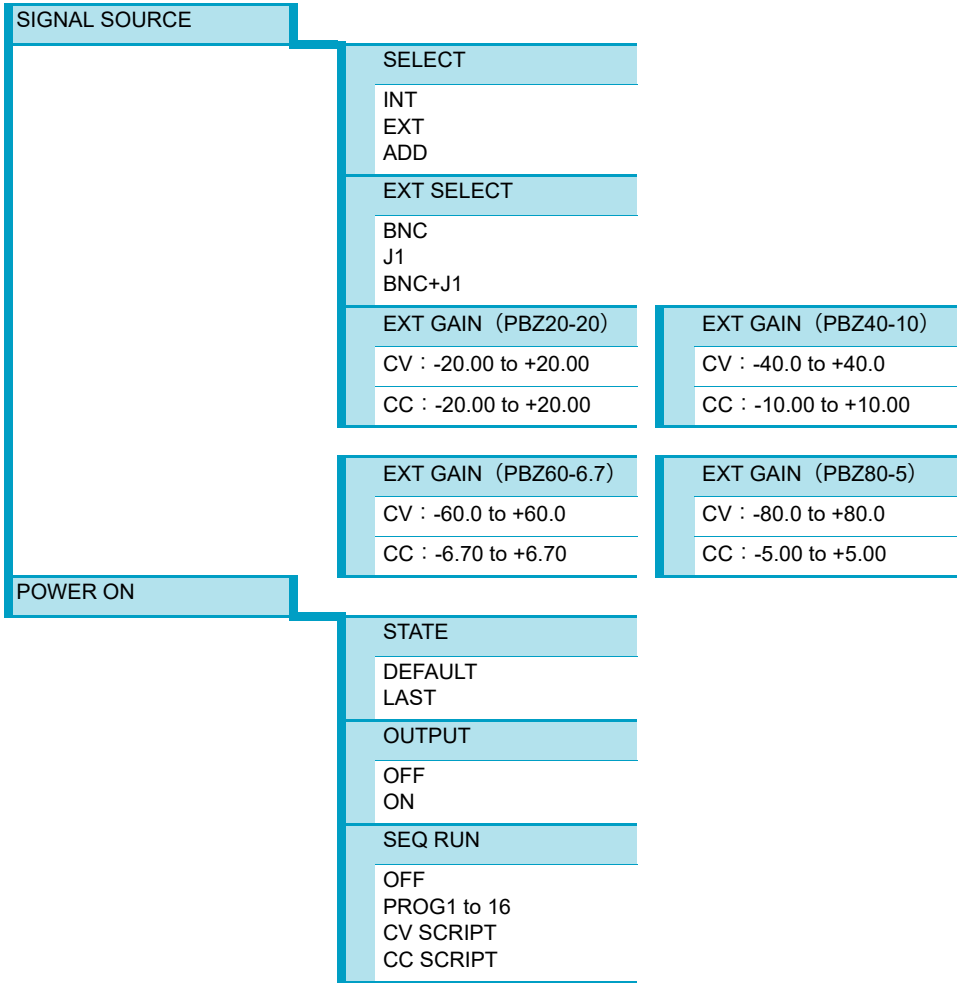

Item	Description	Value	Actual value	Factory default setting
SIGNAL SOURCE >SELECT	Signal source.	INT	Internal signal source.	INT
		EXT	External signal source.	
		ADD	INT and EXT are added.	

Item	Description	Value	Actual value	Factory default setting
SIGNAL SOURCE >EXT SELECT	External signal source.	BNC	The input signal that is applied to EXT SIG IN (BNC terminal).	BNC
		J1	Internal signal source's DC signal that is controlled using a control signal (applied to the J1 connector).	
		BNC+J1	BNC and J1 are added.	
SIGNAL SOURCE >EXT GAIN	External signal circuit gain (negative input is inverted and amplified) ¹	PBZ20-20 : -20.00 to +20.00	CV mode (resolution PBZ20-20 : 0.01	+0 (not inverted)
		PBZ40-10 : -40.0 to +40.0	PBZ40-10/PBZ60-6.7/ PBZ80-5 : 0.1)	
		PBZ60-6.7 : -60.0 to +60.0	Unit: V/V	
		PBZ80-5 : -80.0 to +80.0		
		PBZ20-20 : -20.00 to +20.00	CC mode (resolution: 0.1).	+0 (not inverted)
		PBZ40-10 : -10.00 to +10.00	Unit: A/V	
		PBZ60-6.7 : -6.70 to +6.70		
		PBZ80-5 : -5.00 to +5.00		
POWER ON >STATE	Power-on state. ²	DEFAULT	Default values. ³	LAST
		LAST	The settings that were in use immediately before the POWER switch was turned off.	
POWER ON >OUTPUT	Power-on output state. If the output is off because of the input signal applied to the external contact, it will not turn on.	OFF	Turns output off. ⁴	OFF
		ON	Turns output on. ⁵	
POWER ON >SEQ RUN	Power-on sequence execution.	OFF	Do not execute a sequence.	OFF
		PROG1 to PROG16	Execute a sequence. The program number to execute.	
		CV SCRIPT CC SCRIPT	Execute a sequence. The script to execute.	

¹For positive values, the sign (+) is not displayed.

² If you select DEFAULT, the next time you turn on the PBZ, it will start with the default values. This setting's default value is LAST, so if you do not change this setting back to DEFAULT, it will reset to LAST the subsequent time you turn on the PBZ. Select DEFAULT when you want to reset the PBZ to the default values the next time that you turn it on.

³ DEFAULT resets the PBZ to its default values. (This manual differentiates between the terms "default values" and "factory default settings.") If the PBZ returns to the default values, the SET, AC, PROT, MEASURE, and CONFIG settings are reset to their factory default settings. The preset memory entries, setup memory entries, and sequences that are saved are not affected.

⁴Fixed to OFF when POWER ON > SEQ RUN is set to a value from PROG1 to PROG16, or set to CV SCRIPT or CC SCRIPT. Fixed to OFF when OPERATION is set to SYNC SLAVE (slave unit) or SYNC SLAVE END (slave end unit).

⁵ Can only be set to ON when POWER ON > SEQ RUN is set to OFF.

NOTE

- You cannot change the following settings when the output is on.
 - CONFIG[2]>SIGNAL SOURCE>SELECT
 - CONFIG[2]>SIGNAL SOURCE>EXT SELECT

CONFIG[3]: Synchronous Operation, Trigger Signals, and Output-On Logic

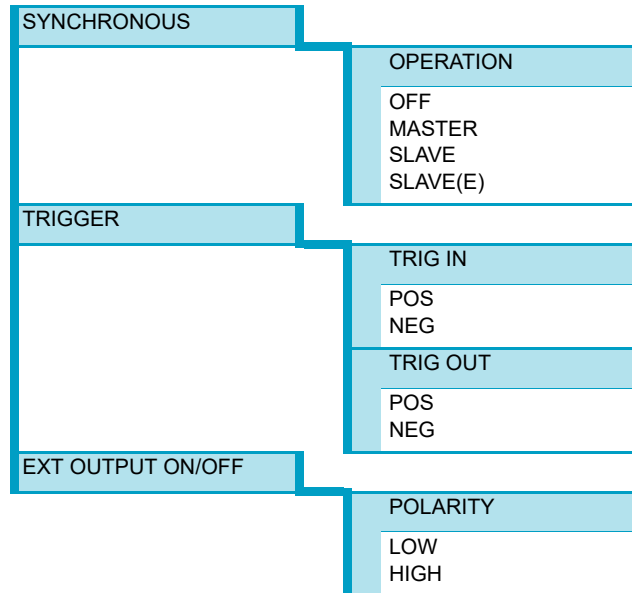

Item	Description	Value	Actual value	Factory default setting
SYNCHRONOUS >OPERATION	Synchronous operation	OFF	Disabled.	OFF
		MASTER	Master unit.	
		SLAVE	Slave unit.	
		SLAVE(E)	Slave end unit.	
TRIGGER >TRIG IN	Polarity of the trigger signal input	POS	High level.	POS
		NEG	Low level.	
TRIGGER >TRIG OUT	Polarity of the trigger signal output	POS	Rising.	POS
		NEG	Falling.	
EXT OUTPUT ON/ OFF >POLARITY	Contact signal logic to turn the output on through external control	LOW	If the contact is in the make state, output turns on.	HIGH
		HIGH	If the contact is in the break state, output turns on.	

NOTE

- You cannot change the following setting when the output is on.
 - CONFIG[3]>SYNCHRONOUS>OPERATION

CONFIG[4]: Memory, Key Lock, and the Buzzer

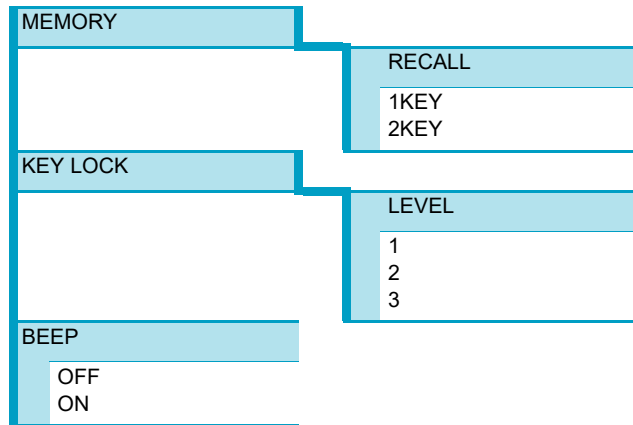

Item	Description	Value	Actual value	Factory default setting
MEMORY RECALL PRESET	Method used to load preset memory entries.	1KEY	One-key operation	2KEY
		2KEY	Two-key operation	
KEY LOCK >LEVEL	The keys that are locked.	1	Low ¹	3
		2	Medium ²	
		3	High ³	
BEEP	Buzzer sound on or off.	OFF	Off	ON
		ON	On	

¹All keys are locked except for the KEY LOCK (SHIFT + LOCAL), OUTPUT, RECALL, A, B, and C keys. (The RECALL key is used to access setup memory entries, and the A, B, and C keys are used to access preset memory entries.)

²All keys are locked except for the KEY LOCK (SHIFT + LOCAL) and OUTPUT keys.

³All keys are locked except for the KEY LOCK (SHIFT + LOCAL) key.

CONFIG[5]: Master or Slave Unit in Parallel Operation

The CONFIG[5] settings do not take effect until you restart the PBZ.

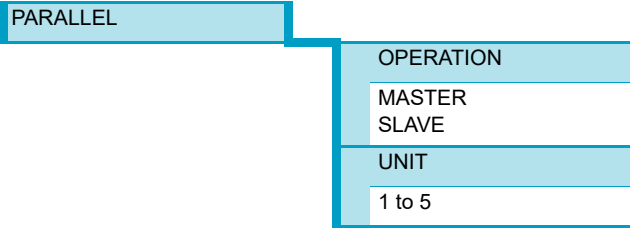

Item	Description	Value	Actual value	Factory default setting
PARALLEL >OPERATION	Master or slave unit in parallel operation	MASTER	Master unit	MASTER
		SLAVE	Slave unit	
PARALLEL >UNIT	Total number of units in parallel operation (including the master unit)	1 to 5	The number of units ¹	1

¹The specifications are only met when you use the parallel operation kit (option PK01-PBZ for operating two units in parallel).

CONFIG[6]: Interface (GPIB, RS232C, USB, and LAN)

The CONFIG[6] settings with the exception of ERR TRACE do not take effect until you restart the PBZ.

INTERFACE	ERR TRACE	OFF ON
	TYPE	GPIB RS232C USB LAN (factory option)
GPIB	ADDRESS	1 to 30
RS232C	BAUDRATE	1200 2400 4800 9600 19200 38400
	DATA BITS	7 8
	STOP BITS	1 2
	PARITY BIT	NONE (fixed)
	X-FLOW	OFF ON
	USB	VENDOR ID
	PRODUCT ID	0x1012
	SERIAL No.	ABC
LAN (factory option)	DHCP	OFF ON
	AUTO IP	OFF ON
	STATUS	STANDBY NO FAULT FAULT IDENTIFY

IP ADDR
xxx.xxx.xxx.xxx
SUBNET
xxx.xxx.xxx.xxx
MAC
xx-xx-xx-xx-xx-xx

Item	Description	Value	Actual value	Factory default setting
INTERFACE >ERR TRACE	Executes a debug trace and displays any communication errors.	OFF	Not displayed	OFF
		ON	Displayed	
INTERFACE >TYPE	Interface to use.	USB	–	USB
		RS232C		
		GPIB		
		LAN ¹		
GPIB >ADDRESS	The GPIB address.	1 to 30	–	1
RS232C >BAUDRATE	The Baud rate.	1200	–	19200
		2400		
		4800		
		9600		
		19200		
		38400		
RS232C >DATA BITS	RS232C data length.	7	–	8
		8		
RS232C >STOP BITS	RS232C stop bit.	1	–	1
		2		
RS232C >PARITY BIT	Parity.	NONE (fixed)	Fixed value.	–
RS232C >X-FLOW	RS232C flow control.	OFF	Disable.	ON
		ON	Enable.	
USB >VENDOR ID	Vendor ID.	0x03BE	Fixed value.	–
USB >PRODUCT ID	Product ID.	0x1012		
USB >SERIAL No.	Serial number.	ABC		
LAN >DHCP	DHCP feature.	OFF	Disable.	ON
		ON	Enable.	
LAN >AUTO IP	Automatic IP address assignment.	OFF	Manual.	ON
		ON	Automatic.	
LAN >STATUS	LAN status display.	STANDBY	—	STANDBY
		NO FAULT	Functioning normally	
		FAULT	Not functioning normally	
		IDENTIFY	Displaying LAN ID data	
LAN >IP ADDR	IP address display.	xxx.xxx.xxx.xxx	–	–
LAN >SUBNET	Subnet mask display.	xxx.xxx.xxx.xxx	–	–
LAN >MAC	MAC address display.	xx-xx-xx-xx-xx-xx	–	–

¹Only when the factory option LAN interface is installed.

CONFIG[7]: Model Information

MODEL INFO	MODEL
	PBZ20-20
	SERIAL No.
	ABC123456
	VERSION
	1.00
	OPTION (Factory option)
	LAN2.00

Item	Description	Value	Actual value	Factory default setting
MODEL INFO >MODEL	Model name display	PBZ20-20 ¹	Fixed value	–
MODEL INFO >SERIAL No.	Serial number display	ABC123456 ^{*1}		
MODEL INFO >VERSION	Firmware version display	1.00 ^{*1}		
MODEL INFO >OPTION ²	Firmware version of LAN interface display	LAN.2.00 ³		–

¹Example for when the model name is PBZ20-20, the serial number is ABC123456, and the firmware version is 1.0.

²Only when the factory option LAN interface is installed.

³Only when the factory option LAN interface is selected. In this example, the firmware version is 2.00.



4

Sequences

This chapter explains sequences.

Sequence Feature

You can use the sequence feature to automatically execute the steps that you have set in advance. You can sequentially update the internal signal source settings, so you can perform a variety of waveform simulations. The sequences that you create are saved to non-volatile memory, so they are not lost when you turn the PBZ off.

Creating Sequences (Scripts, Programs, and Steps)

Sequences are created from the elements that are listed below. Scripts are created from programs, and programs are created from steps.

- **Scripts (SCRIPT)**

Scripts are made of program execution sequences. There is one script in CV mode and one script in CC mode.

- **Programs (PROGRAM)**

Programs are made of output patterns that are created from multiple steps. There are a total of 16 programs. Programs can be used in both CV mode and CC mode.

- **Steps (STEP)**

You can specify one output pattern with one step. There are a total of 1024 steps. Steps can be used in both CV mode and CC mode.

CV mode

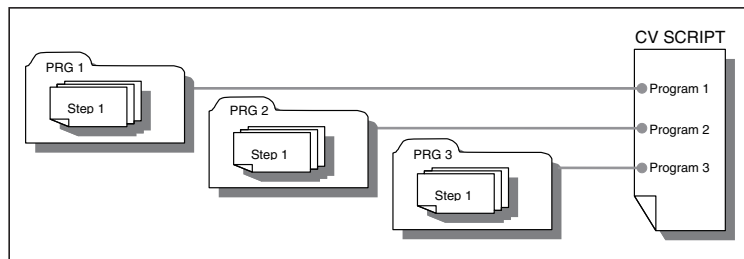

CC mode

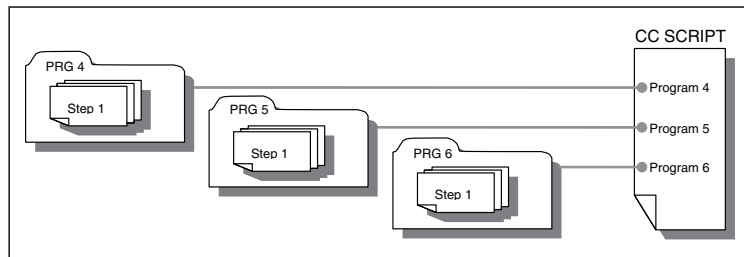

Sample programs are available as part of the factory default settings. You can change the sample programs.

Sequence Execution Methods

You can execute a sequence in one of the following two ways:

- By executing a program

The PBZ executes the program that you specify by its program number. The program begins execution from the first step that it contains.

- By executing a script

The PBZ executes all the programs in the script in their sequential order. You can execute the programs in order, repeatedly execute a single program, or repeatedly execute a series of programs.

Program execution flowchart (overview)

See p. 112

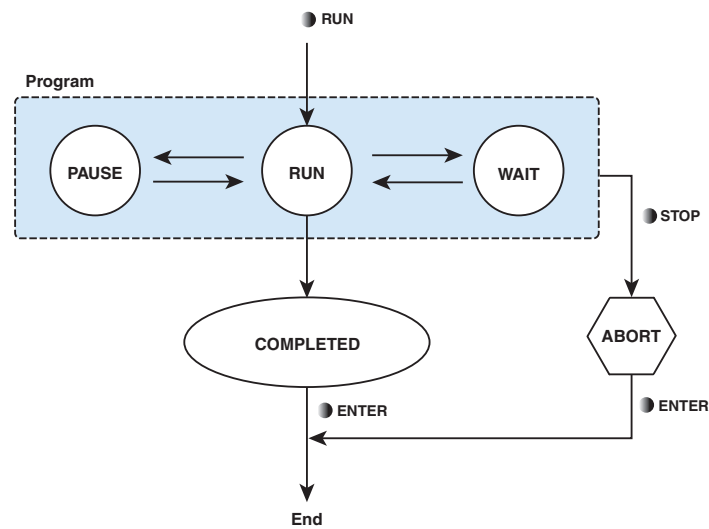

- Specify a program number and execute it (press RUN/PAUSE).
- If you press RUN/PAUSE, the execution is paused.
- If the program is designed to wait for a trigger signal, it enters the WAIT state.
- When the program finishes execution, press ENTER.
- To abort execution, press STOP or OUTPUT.

Script execution flowchart (overview)

See p. 121

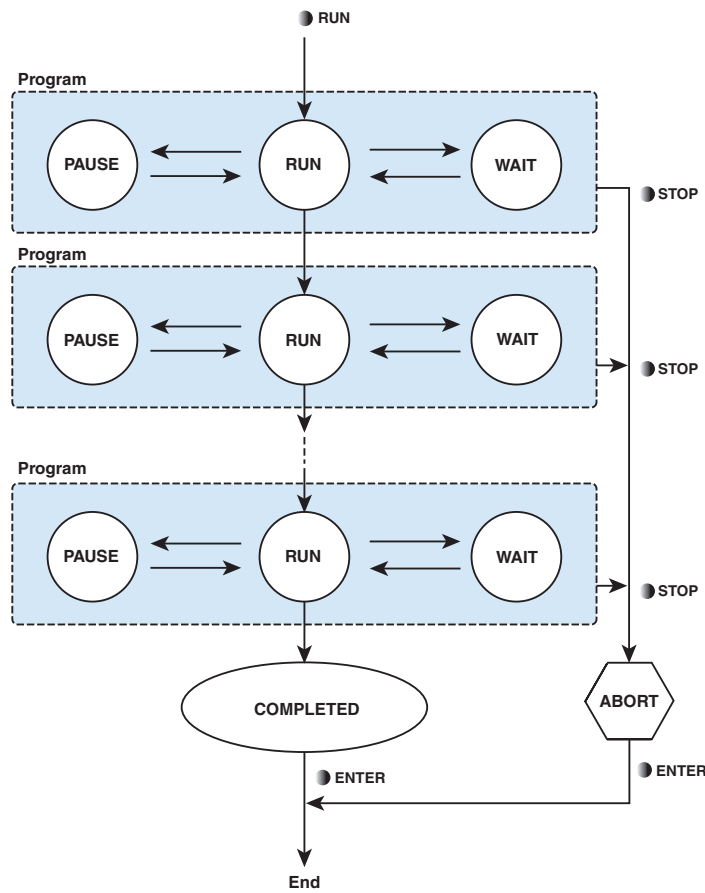

- Press RUN/PAUSE to start the execution.
- The programs in the script are executed according to the instructions in the script.
- If you press RUN/PAUSE, the execution is paused.
- If the program is designed to wait for a trigger signal, it enters the WAIT state.
- When all of the programs in the script finish execution, press ENTER.
- To abort execution, press STOP or OUTPUT.

Executing Sequences across Multiple Synchronized Units

See p. 148

You can use the synchronization feature to execute sequences in sync across multiple units.

Editing Programs and Steps

Program editing flowchart

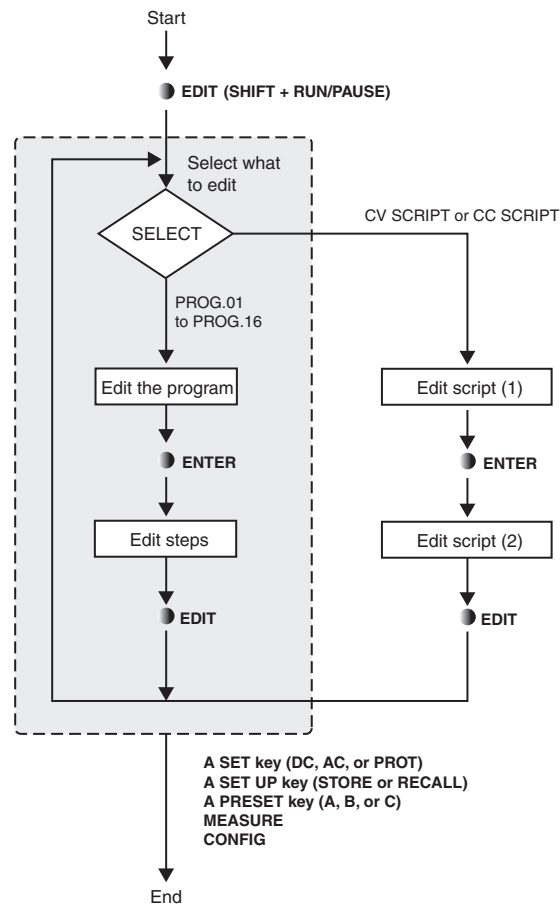

- Press EDIT (SHIFT + RUN/PAUSE) to begin editing the program.
- When you finish editing the program, to edit the program's steps, press ENTER.
- When you are finished, press a key other than EDIT (SHIFT + RUN/PAUSE) or ENTER.
- Edited programs and steps are stored in non-volatile memory. If you use **CONFIG** to change settings to DEFAULT (the default values), saved sequences are not affected. If you reset the PBZ to its factory default settings, all the sequences are cleared. (This manual differentiates between the terms "default values" and "factory default settings.")

See p. 87

Editing Programs

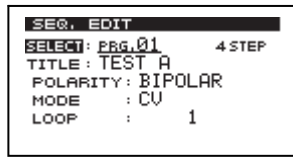

Item	Input range	Description	Factory default setting
SELECT	PRG.01 to PRG.16	Program number.	1
TITLE	Up to 15 characters ASCII codes 0x20 to 0x7E	Program name.	UNTITLED
POLARITY	BIPOLAR or UNIPOLAR	Bipolar/unipolar mode.	Bipolar mode
MODE	CV or CC	CV/CC mode.	CV
LOOP	1 to 10000 or ∞	The number of times that the program will repeat. If you specify ∞, the program will repeat infinitely.	1

You can edit the SELECT, TITLE, POLARITY, MODE, and LOOP settings in any order that you want. Use the up and down cursor keys to select a setting.

Match the POLARITY (bipolar/unipolar mode) and MODE (CV/CC mode) settings to the operation modes that you have used **CONFIG** to specify.

See p. 86

Starting the editing of a program

1 Press EDIT (SHIFT + RUN/PAUSE).

The program editing screen appears.

The selected program's TITLE (program name), POLARITY (bipolar/unipolar mode), MODE (CV/CC mode), LOOP (the number of times the program will repeat), and STEP (the number of steps that the program contains) settings are displayed. Sample programs have specific titles (program names), but all other programs are named "UNTITLED."

Selecting the program number

1 Use the up and down cursor keys to select SELECT.

2 Turn the rotary knob to select the number of the program that you want to edit.

The selectable range of program numbers is from 1 to 16. If you fix the number that you specified using the rotary knob, the number is confirmed.

Entering the program name (changing characters)

1 Use the up and down cursor keys to select TITLE.

2 Use the left and right cursor keys to select the character that you want to change.

3 Turn the rotary knob to select the character.

You can select ASCII code characters in the range of 0x20 to 0x7E. If you fix the character that you specified using the rotary knob, the character is confirmed. To add or delete characters, proceed to the following steps.

Entering the program name (adding and deleting characters)

- 4 Use the left and right cursor keys to select a character.**
- 5 Press INS (SHIFT + the up cursor key).**
A space is inserted at the cursor position.
If you press DEL (SHIFT + the down cursor key), the character at the cursor position is deleted.
- 6 Turn the rotary knob to select the character.**
The space changes to the selected character. You can select ASCII code characters in the range of 0x20 to 0x7E. You can enter up to 15 characters. If you want to continue entering characters, repeat steps Procedure 4 to Procedure 6.

Selecting the bipolar/unipolar mode

- 1 Use the up and down cursor keys to select POLARITY.**
- 2 Turn the rotary knob to select BIPOLAR or UNIPOLAR.**

Selecting CV/CC mode

- 1 Use the up and down cursor keys to select MODE.**
- 2 Turn the rotary knob to select CV or CC.**

Selecting the number of times that the program will repeat

- 1 Use the up and down cursor keys to select LOOP.**
- 2 Turn the rotary knob to specify the number of times that the program will repeat.**
The input range is from 1 to 10000. You can also specify ∞ (infinity). If you fix the number that you specified using the rotary knob, the number is confirmed.

Starting the editing of steps

- 3 Press ENTER.**
The step editing screen (page 1/5) appears. For information about the step editing procedure, see 「Editing Steps」.

Ending the editing of the program

- **Press a key other than EDIT (SHIFT + RUN/PAUSE) or ENTER.**
Program editing completes, and the PBZ switches to the feature for the key that you pressed. The PBZ saves the edited program.

Editing Steps

This section will explain how to edit the steps for the program number that was selected through the procedure given on “Editing Programs” on page 100.

The step editing screen contains five pages (page 1/5 to page 5/5). You can edit these pages in any order that you want. To select the page you want to edit, use the up and down cursor keys to move through the settings. You can use a total of 1024 steps in PRG.01 to PRG.16.

First, select the page to edit on the editing screen. Then, select the setting to edit in the page. The STEP and TIME settings can be edited from any page.

See p. 106

Selecting the step editing page

1 Use the up and down cursor keys to select a step editing page.

To move between pages on the step editing screen, repeatedly press the up or down cursor key (in the direction that you want to move). When the cursor is on the first or last setting on the page and you press the appropriate cursor key, the page will switch to the previous or next page, respectively.

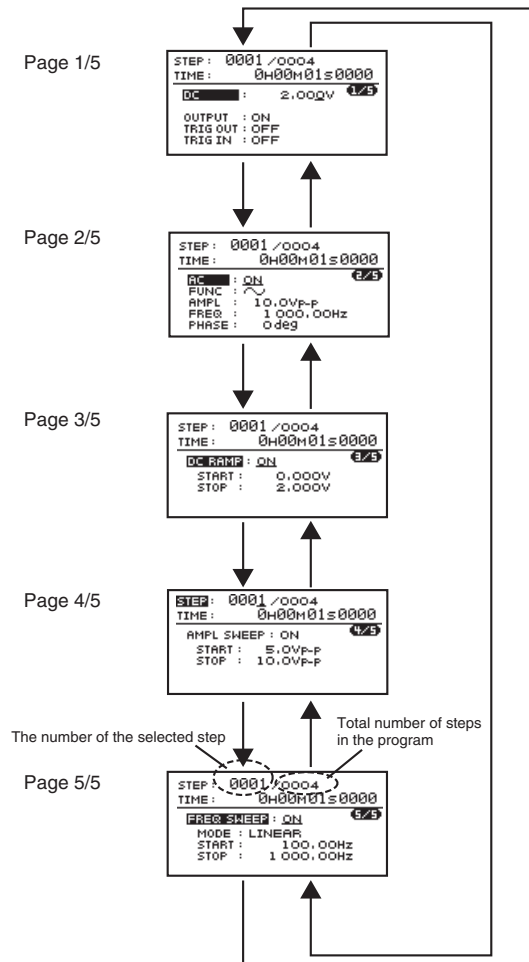

Selecting and specifying the step number

1 Use the up and down cursor keys to select STEP.

If there are steps already in the program, the cursor moves to the step number.

If there are no steps in the program, "END" is displayed, and the cursor moves to "END." If "END" is displayed, the number of steps in the program is 0000.
 If there are no steps in the program, proceed to the next step. Otherwise, proceed to Procedure 3.

2 Press INS (SHIFT + the up cursor key).

The number of steps in the selected program (the right-hand number next to STEP) is displayed as 0001.
 You can insert from 0001 to 1024 steps (you can use a total of 1024 steps in PRG.01 to PRG.16).

3 Turn the rotary knob to select the step number.

Specifying step settings

1 Use the up and down cursor keys to select a step setting.

2 Turn the rotary knob to specify the setting.

If the setting takes a number, you can also use the numeric keys to specify it.

Inserting new steps at a specified step number

1 Use the up and down cursor keys to select STEP.

2 Turn the rotary knob to select the step number you want to insert the new step into.

3 Press INS (SHIFT + the up cursor key).

A new step is inserted before the selected step number. You can use a total of 1024 steps in PRG.01 to PRG.16.

Example 1: Inserting one step

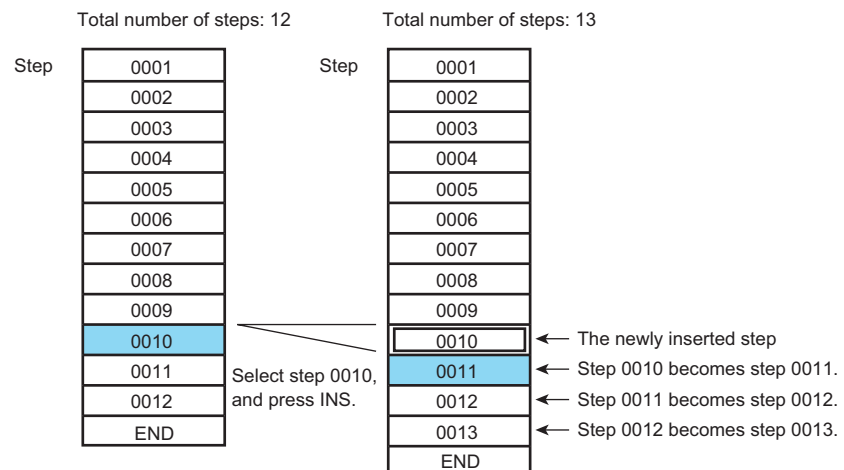

Example 2: Inserting five steps

If you want to insert multiple steps, it is useful to insert all of them at once.

Select the step number where you want to insert the steps, and press INS multiple times (five times in the following figure). After the steps are inserted, select each new step, and edit its contents.

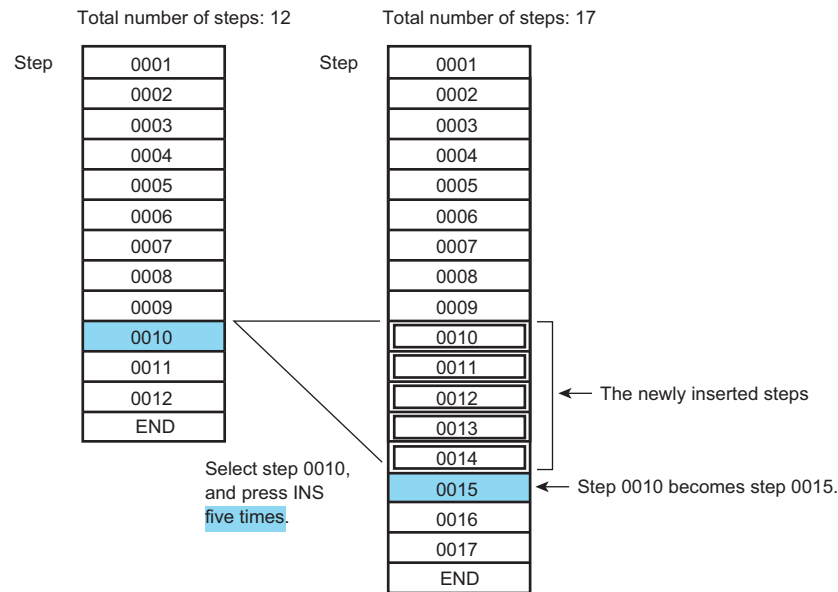

4 Follow the steps in 「Specifying step settings」 to specify the step settings.

Deleting steps

- 1** Use the up and down cursor keys to select STEP.
- 2** Turn the rotary knob to select the number for the step that you want to delete.
- 3** Press DEL (SHIFT + the down cursor key).
The step that corresponds to the selected step number is deleted.

Adding new steps after the last step

- 1** Use the up and down cursor keys to select STEP.
- 2** Turn the rotary knob clockwise to select "END."
The number for the last step that has been edited is displayed.
- 3** Press INS (SHIFT + the up cursor key).
A new step is added after the last step. You can use a total of 1024 steps in PRG.01 to PRG.16.

Example: Adding a step after the last step

A new step is added after the last step.

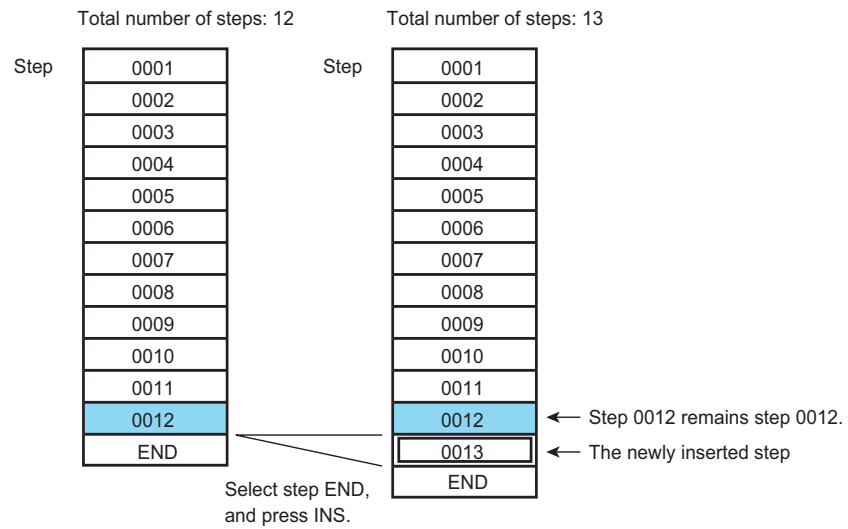

- 4 Follow the steps in 「Specifying step settings」 to specify the step settings.

Returning to program editing

- Press **EDIT (SHIFT + RUN/PAUSE)**.

The program editing screen appears.

Ending the editing of the program

- Press a key other than **EDIT (SHIFT + RUN/PAUSE)** or **ENTER**.

Program editing completes, and the PBZ switches to the feature for the key that you pressed. The PBZ saves the edited program.

Step Settings

Step settings are displayed on the screen. Specify each setting within its input range.

Step Settings

The step editing screen is separated across five pages. AC signals use the internal signal source.

- DC signal and triggers (page 1/5)
- AC signal amplitude and frequency (page 2/5)
- DC signal ramp (slope) transitions (page 3/5)
- AC signal and amplitude sweep (page 4/5)
- AC signal and frequency sweep (page 5/5)

DC signal and triggers (page 1/5)

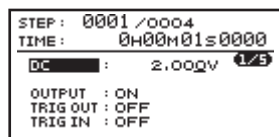

Item	Input range	Description	Factory default setting
STEP	1 to 1024	The step number/the total number of steps in the program. You can use a total of 1024 steps in PRG.01 to PRG.16.	–
TIME	0:00:00.0001 0.1 ms to 1000 h ^{*1}	The step execution time. Hours : minutes : seconds; the resolution is 0.1 ms.	1 s
DC	The same as the DC signal's input range	The DC signal setting. The input ranges for some settings differ between bipolar and unipolar modes. See p. 40	0 V
OUTPUT	ON or OFF	ON: The output is turned on. OFF: The output is turned off.	ON
TRIG OUT	ON or OFF	ON: A trigger signal is generated when step execution time begins. OFF: Trigger signals are not generated.	OFF
TRIG IN	ON or OFF	ON: The PBZ enters the trigger signal input standby state when step execution time begins. OFF: Trigger signals are not detected.	OFF

[See](#) p. 132

*1 The DC signal ramp and AC signal amplitude sweep both stop after 1000 seconds. The AC signal frequency sweep repeats once every 1000 seconds. If you want to perform these functions for lengths of time exceeding 1000 seconds, you have to combine multiple steps.

● **OUTPUT (output on and off)**

- ON: The output is turned on.
- OFF: The output is turned off.

NOTE

The time to switch the output from off to on or from on to off is added to the step execution time.

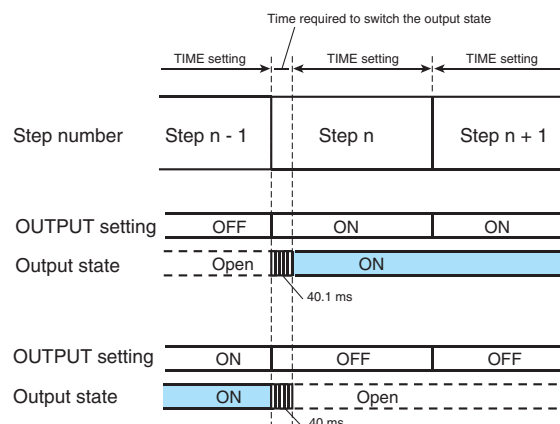

● **TRIG OUT (trigger signal output)**

- ON: A trigger signal is generated when step execution time begins.
- OFF: Trigger signals are not generated.

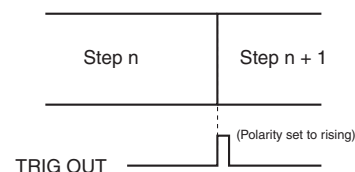

See p. 89 , p. 148

You can select the output trigger signal polarity (rising or falling). Use **CONFIG** to select the slope.

● **TRIG IN (trigger signal input)**

Use TRIG IN to set the PBZ's response to trigger signal input.

- ON: The PBZ waits for a trigger signal to be applied when step execution time begins (the PBZ enters the WAIT state).
- OFF: Trigger signals are not detected.

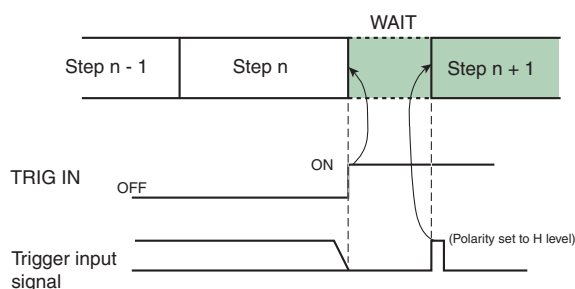

The trigger signal input type is level trigger. You can set the level polarity to either H (high) or L (low). Use **CONFIG** to select the level.

AC signal amplitude and frequency (page 2/5)

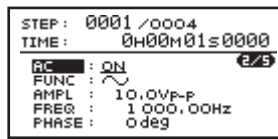

Item	Input range	Description	Factory default setting
AC	ON or OFF	ON: The AC signal, which is superimposed on the DC signal, is turned on. OFF: The AC signal, which is superimposed on the DC signal, is turned off.	OFF
FUNC	Sine wave Square wave Triangle wave ARB1 to ARB16	AC signal waveform: Sine wave. Square wave. Triangle wave. ARB1 to ARB16 are user-defined arbitrary waveforms.	Sine wave
AMPL	The same as the AMPL setting's input range	AC signal's amplitude setting. The input ranges for some settings differ between bipolar and unipolar modes. See p. 46	0 Vp-p
FREQ	The same as the FREQ setting's input range	AC signal's frequency setting. See p. 47	1000 Hz
PHASE	FREE or from 0 deg to 359 deg	AC signal start phase angle. The resolution is 1 deg.	0 deg
DUTY	0.1 to 99.9 %	Square wave duty ratio. When $f < 100$ Hz, the resolution is 0.1 %. ¹	50 %
	1 to 99 %	When $100 \text{ Hz} \leq f < 1 \text{ kHz}$, the resolution is 1 %.	
	10 to 90 %	When $1 \text{ kHz} \leq f < 10 \text{ kHz}$, the resolution is 10 %.	
	50 % (fixed)	When the signal frequency is 10 kHz.	

¹f is the signal frequency.

DC signal ramp (slope) transitions (page 3/5)

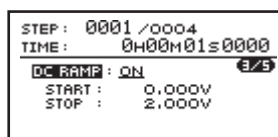

Item	Input range	Description	Factory default setting
DC RAMP	ON or OFF	ON: The DC signal ramps up gradually to the DC setting over time. When the step execution time finishes, the signal is at the specified setting. OFF: The DC signal jumps immediately to the DC setting. The signal is at the specified setting from the start of the step execution time.	OFF
START		DC signal start value.	0 V
STOP	The same as the DC signal's input range	DC signal stop value. The input ranges for some settings differ between bipolar and unipolar modes. If you change this setting, the DC setting on step editing page 1/5 also changes, and vice-versa.	0 V

● RAMP

Use RAMP to set how the DC signal will change over time.

- ON: The DC signal ramps up gradually to the DC setting over time. When the step execution time finishes, the signal is at the specified setting.^{*1}
- OFF: The DC signal jumps immediately to the DC setting. The signal is at the specified setting from the start of the step execution time.

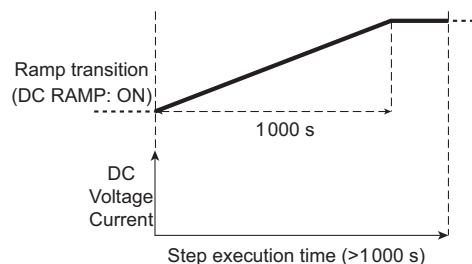
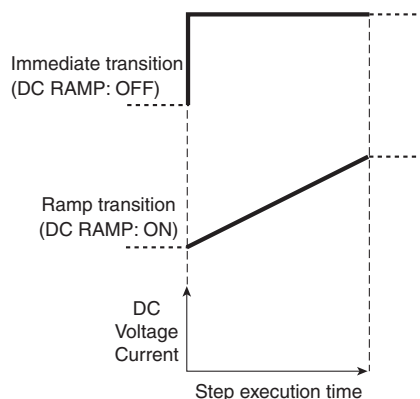

*1 If the step time exceeds 1000 seconds, the DC signal level after 1000 seconds is the same as the DC signal stop setting (STOP). If you want to perform a ramp transition that takes longer than 1000 seconds, you have to combine multiple steps.

See p. 132

AC signal and amplitude sweep (page 4/5)

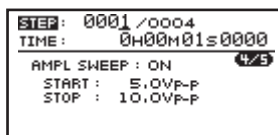

Item	Input range	Description	Factory default setting
AMPL SWEEP	ON or OFF	The AC signal amplitude sweep setting. ON: The PBZ sweeps from the specified start amplitude to the specified stop amplitude. OFF: Sweeps are not executed.	OFF
START	The same as the AMPL setting's input range See p. 46	The AC signal start (START) and stop (STOP) amplitudes. ^{*1}	0 Vp-p
STOP		The input ranges for some settings differ between bipolar and unipolar modes. If you change these settings, the AMPL setting on step editing page 2/5 also changes, and vice-versa.	0 Vp-p

*1 If the step time exceeds 1000 seconds, the AC signal amplitude level after 1000 seconds is the same as the stop amplitude setting (STOP). If you want to perform an AC signal amplitude sweep that takes longer than 1000 seconds, you have to combine multiple steps.

To invert the AC signal output, set the AMPL setting to a negative value. To not invert the output, set the AMPL setting to a positive value. Whether you choose to invert the output signal or not, be sure that the start (START) and stop (STOP) amplitudes have the same sign.

See p. 132

AC signal and frequency sweep (page 5/5)

```
STEP: 0001 / 0004
TIME: 0H00M01s0000
FREQ SWEEP: ON 5/5
MODE: LINEAR
START: 100.00Hz
STOP: 1000.00Hz
```

Item	Input range	Description	Factory default setting
FREQ SWEEP	ON or OFF	The AC signal frequency sweep setting. ON: The PBZ sweeps from the specified start frequency to the specified stop frequency. OFF: Sweeps are not executed.	OFF
MODE	LINEAR or LOG	The AC signal frequency sweep mode setting. LINEAR: The frequency is changed linearly over the step execution time. LOG: The frequency is changed logarithmically over the step execution time.	LINEAR
START	The same as the FREQ setting's input range See p. 50	The AC signal start (START) and stop (STOP) frequencies.*1 If you change these settings, the FREQ setting on step editing page 2/5 also changes, and vice-versa.	1000 Hz
STOP			1000 Hz

[See](#) p. 132

*1 If the step time exceeds 1000 seconds, the frequency sweep from the specified start frequency to the specified stop frequency is repeated after 1000 seconds. If you want to perform an AC signal frequency sweep that takes longer than 1000 seconds, you have to combine multiple steps.

Practical Examples of Step Settings

This section gives two practical examples of step settings.

■ DC RAMP: ON, AMPL SWEEP: OFF, FREQ SWEEP: OFF

To make the DC signal ramp up gradually over time and make the AC signal amplitude constant

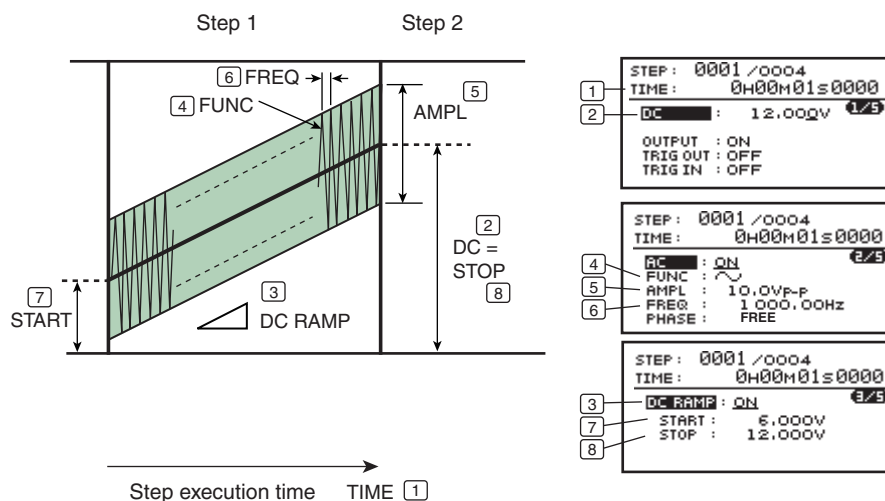

● Summary of the practical example

Item	At the beginning of step execution	At the end of step execution
DC signal value	DC signal start value	Because DC RAMP is set to ON, when the step execution time finishes, the DC signal is at the specified DC setting.
AC signal amplitude	Because SWEEP is set to OFF, AMPL is set to the AMPL setting when the step execution begins. The AC signal amplitude that the PBZ was set to when the previous step completed execution does not continue into this step.	Because SWEEP is set to OFF, AMPL remains at the same AMPL setting (that it was set to when step execution began) from the start to the end of step execution. The AC signal amplitude that the PBZ is set to when this step completes execution does not continue into the next step.
AC signal start phase angle	Because PHASE is set to FREE, the start phase angle is indeterminate.	Regardless of the PHASE setting, the phase angle is indeterminate.

■ DC RAMP: OFF, AMPL SWEEP: ON, FREQ SWEEP: OFF

To make the DC signal jump to its specified value immediately and sweep the AC signal amplitude

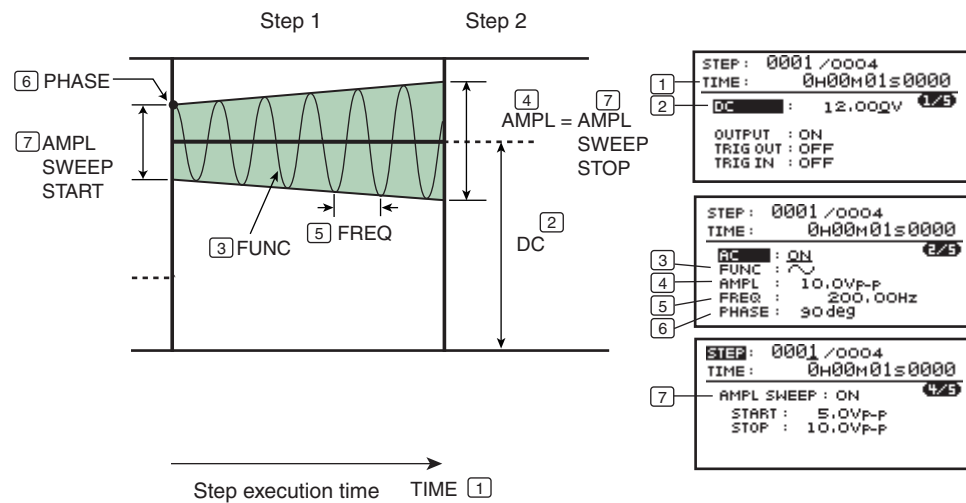

● Summary of the practical example

Item	At the beginning of step execution	At the end of step execution
DC signal value	Because DC RAMP is set to OFF, when the step execution time starts, the DC signal is at the specified DC setting.	Because DC RAMP is set to OFF, the DC value remains at the same DC setting (that it was set to when step execution began) from the start to the end of step execution.
AC signal amplitude	Because SWEEP is set to ON, the amplitude is set to the START setting when the step execution begins. The AC signal amplitude that the PBZ was set to when the previous step completed execution does not continue into this step.	Because SWEEP is set to ON, the amplitude is set to the STOP setting when the step execution begins. The AC signal amplitude that the PBZ is set to when this step completes execution does not continue into the next step.
AC signal start phase angle	PHASE is set to 90 °.	Regardless of the PHASE setting, the phase angle is indeterminate.

Executing Programs

Program execution flowchart

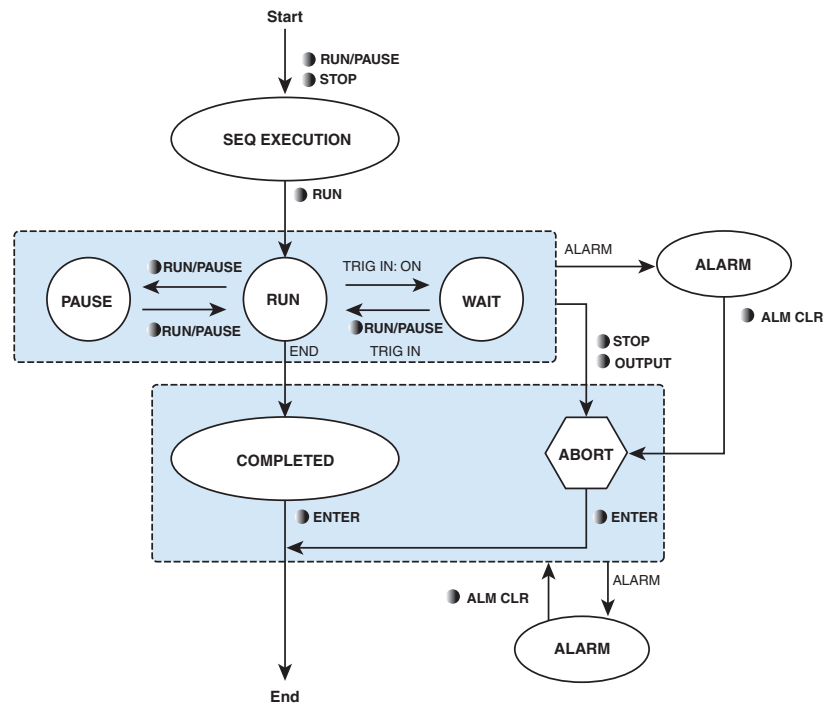

- Press RUN/PAUSE or STOP to make the PBZ enter the program execution (SEQ EXECUTION) state.
- Specify a program number and execute it (press RUN/PAUSE).
- If you press RUN/PAUSE while a program is executing, the execution is paused.
- If the program is designed to wait for a trigger signal, it enters the WAIT state.
- When a program completes, the PBZ enters the COMPLETED state.
- Press ENTER.
The PBZ returns to the state where you can set the DC signal (as if you had pressed the DC key).
- To abort execution, press STOP or OUTPUT. If you press OUTPUT, regardless of the programmed output settings, the output is turned off.
- If an alarm is generated, the PBZ enters the ALARM state.

■ If a protection feature is activated during program execution

If OVP, OCP, or OHP is activated during program execution, an alarm is generated.

■ Setting the protection features during program execution

You can set the protection features during program execution.

■ Setting the measurement feature during program execution

You can set the measurement feature during program execution.

See p. 66

See p. 116

See p. 116

Executing Programs (RUN)

1 Press RUN/PAUSE or STOP.

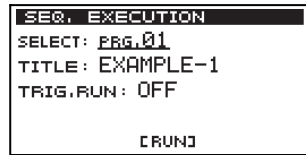

The sequence start screen (SEQ EXECUTION) appears. If you do not want to start program execution, press a key other than the RUN/PAUSE or STOP key.

2 Use the up and down cursor keys to select SELECT.

3 Turn the rotary knob to select the number of the program (1 to 16) that you want to execute.

The program name is displayed next to TITLE.

If the PBZ is currently in CV mode, select programs that were edited for CV mode. If the PBZ is currently in CC mode, select programs that were edited for CC mode.

See p. 86

NOTE

- When you are editing programs, you can select which program to edit independent of the CV/CC mode setting. If you execute a program that was edited for a mode (CV/CC mode) that does not match the current mode (CV/CC mode) of the PBZ, an error will be generated.

4 Use the up and down cursor keys to select TRIG.RUN.

5 Turn the rotary knob to select ON or OFF.

If you select ON, execution will begin when a TRIG IN signal is applied. If you select OFF, execution will begin immediately.

If you have used **CONFIG** to set OPERATION (synchronous operation) to SYNC SLAVE or SYNC SLAVE END, you cannot specify this setting. Instead of ON or OFF, "--" is displayed.

See p. 89

6 Press RUN/PAUSE to start program execution.

The selected program begins executing. The RUN/PAUSE key is illuminated during execution.



PROG: The number of the program that is executing (from 1 to 16).

LOOP: The program's current loop number.

If this number exceeds 10000, "#####" is displayed.

STEP: The step number that is being executed (1 to 1024).

Time elapsed since the step began executing (hours : minutes : seconds).

When the program finishes executing, the program

completed screen (COMPLETED) appears. The RUN/PAUSE key turns off, and the STOP key illuminates.



7 Press ENTER.

The program completes. The PBZ maintains the programmed output settings at the time when the program completed.

The STOP key turns off, and the PBZ returns to the state where you can set the DC signal (as if you had pressed the DC key).

Executing programs when the POWER switch is turned on

See p. 87

Use **CONFIG** in advance to specify the number of the program to execute. When the POWER switch is turned on, the PBZ begins execution from the specified program.

Aborting Programs (ABORT)

1 Press STOP or OUTPUT.

The RUN/PAUSE key turns off, and the STOP key illuminates. If you press one of these keys while a program is in the RUN, PAUSE, or WAIT state, the program execution stops, and the program execution stopped screen (ABORT) appears. The PBZ maintains the programmed output settings at the time when the program was stopped.

If you press OUTPUT, regardless of the programmed output settings, the output is turned off.

C.V INT	SEQ: STOP
-0.010A	0.010V
DC	
SEQ. Abort.	
PUSH ENTER KEY	

2 Press ENTER.

The program completes. The PBZ maintains the programmed output settings at the time when the program completed. The STOP key turns off, and the PBZ returns to the state where you can set the DC signal (as if you had pressed the DC key).

Pausing Programs (PAUSE)

If you press the RUN/PAUSE key while a program is executing, the program execution pauses, and the PAUSE screen appears. To resume program execution, press the RUN/PAUSE key again. If you press the STOP key while program execution is paused, the program execution will be aborted.

1 Press RUN/PAUSE.

The RUN/PAUSE key blinks. The PAUSE screen appears, and the program execution is paused. The PBZ maintains the programmed output settings at the time when the program was paused.

C.V INT	SEQ: PAUSE
-0.009A	0.010V
DC	
PROG: 1	LOOP: 1
STEP: 1	0H00M05s5

PROG: The number of the program that is executing (from 1 to 16).

LOOP: The program's current loop number.

If this number exceeds 10000, "#####" is displayed.

STEP: The step number that is being executed (1 to 1024).

Time elapsed since the step began executing (hours : minutes : seconds).

Resuming the execution of a paused program

2 Press RUN/PAUSE.

The execution screen appears, and the program resumes execution. The RUN key illuminates.

Pausing Programs to Wait for Trigger Input Signals (WAIT)

When a program contains a step that sets the PBZ to wait for a trigger input signal (TRIG IN is set to ON), the PBZ automatically pauses program execution (enters the WAIT state) after that step is executed. You can resume program execution by applying a trigger input signal to the TRIG IN terminal on the PBZ's rear panel.

CWI INT	
SER: WAITING	
-0.009A	0.010V
DC	
PROG: 1	LOOP: 1
STEP: 2	0H00M00S0

PROG: The number of the program that is executing (from 1 to 16).

LOOP: The program's current loop number.

If this number exceeds 10000, "#####" is displayed.

STEP: The step number that is being executed (1 to 1024).

Time elapsed since the step began executing (hours : minutes : seconds).

Resuming the execution of a paused program

1 Apply a trigger input signal to the TRIG IN terminal, or press RUN/PAUSE.

The execution screen appears, and the program resumes execution.

Remedying Alarm Generation

If an alarm is generated, the PBZ enters the ALARM state. The causes of the alarm are displayed on the screen, so first eliminate all the causes that are listed. Then, there are additional remedies that depend on whether the alarm was generated during program execution or when a program completed execution (including the case when the program was aborted).

The alarm was generated during program execution

1 Press ALM CLR (SHIFT + PROT).

The alarm is cleared. Program execution is stopped, and the program execution stopped (ABORT) screen appears. The PBZ maintains the programmed output settings at the time when the program was stopped.

2 Press ENTER.

The sequence finishes. The PBZ maintains the programmed output settings at the time when the sequence completed. The PBZ returns to the state where you can set the DC signal (as if you had pressed the DC key).

The alarm was generated when the program completed execution

1 Press ALM CLR (SHIFT + PROT).

The alarm is cleared.

Setting the Protection Features during Program Execution

See p. 67

1 Press PROT.

The PROT key blinks. The setup screen appears.

2 Use the up and down cursor keys to select a setting.

The cursor moves to the setting that you want to specify. You can switch the page by continuously pressing the up or down cursor key. The setting procedure is the same as the normal procedure to set protection activation points.

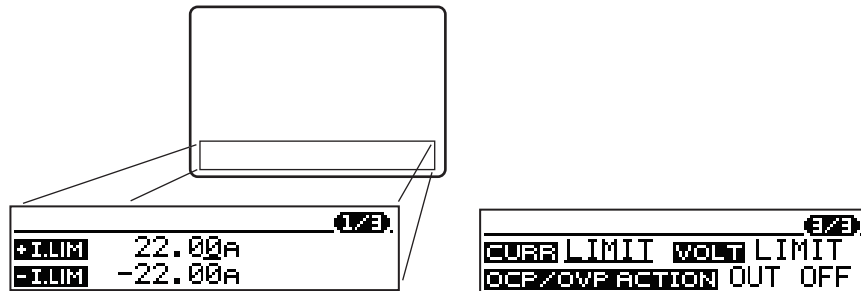

3 Press PROT to finish.

The PROT key turns off. The setup screen disappears, and the protection feature setup completes.

NOTE

If an alarm is generated during protection feature setup, the program is aborted. Eliminate all of the causes of the alarm.

Setting the Measurement Feature during Program Execution

See p. 61

1 Press MEASURE.

The MEASURE key blinks, and the MEASURE setup screen appears.

2 Use the up and down cursor keys to select a setting.

The cursor moves to the setting that you want to specify. You can switch the page by continuously pressing the up or down cursor key. The setting procedure is the same as the normal procedure to set the measurement feature.



3 Press MEASURE to finish.

The MEASURE key turns off. The setup screen disappears, and the measure feature setup completes.

Editing Scripts

Script editing flowchart

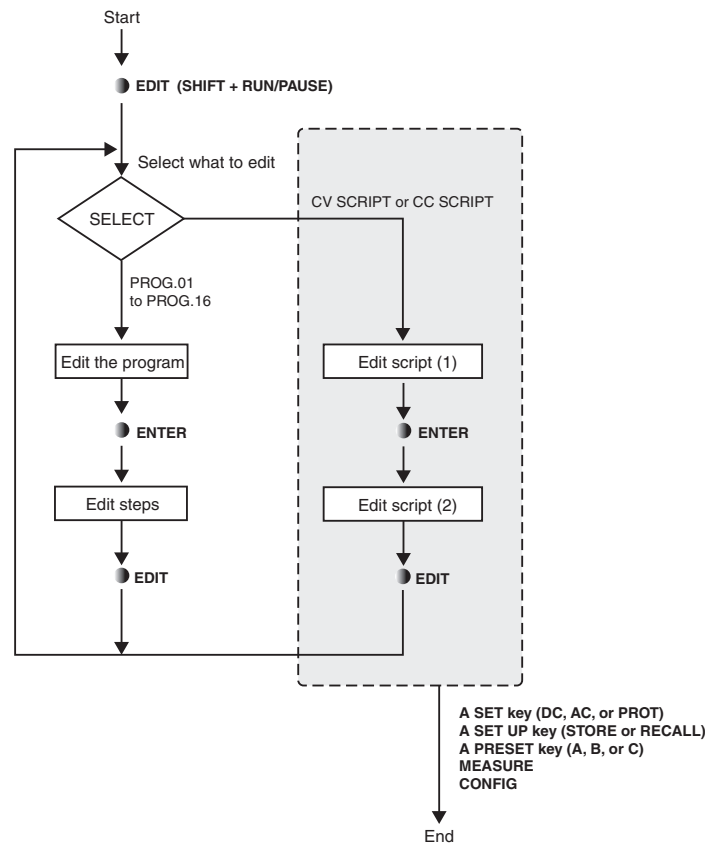

- Press EDIT (SHIFT + RUN/PAUSE) to begin editing Script1.
- When you finish editing Script1 and you want to edit Script2, press ENTER.
- When you are finished, press a key other than EDIT (SHIFT + RUN/PAUSE) or ENTER.

Editing Script1

```
SEQ. EDIT
SELECT: CV SCRIPT
TITLE: --UNTITLED--
```

You can edit the SELECT, TITLE, and POLARITY settings in any order that you want. Use the up and down cursor keys to select a setting. You can make one script in CV mode and one script in CC mode.

Match the SELECT (CV SCRIPT or CC SCRIPT) setting to the operation mode (CV or CC) that you have used **CONFIG** to specify.

See p. 86

Starting the editing of a script

1 Press EDIT (SHIFT + RUN/PAUSE).

The program editing screen appears.

The selected program's TITLE (program name), POLARITY (bipolar/unipolar mode), MODE (CV/CC mode), LOOP (the number of times the program will repeat), and STEP (the number of steps that the program contains) settings are displayed. Sample programs have specific titles (program names), but all other programs are named "UNTITLED."

Selecting a script

1 Use the up and down cursor keys to select SELECT.

2 Turn the rotary knob to select the script that you want to edit.

Select CV SCRIPT for CV mode. Select CC SCRIPT for CC mode.

Specifying the script name (changing characters)

1 Use the up and down cursor keys to select TITLE.

2 Use the left and right cursor keys to select the character that you want to change.

3 Turn the rotary knob to select the character.

You can select ASCII code characters in the range of 0x20 to 0x7E. If you fix the character that you specified using the rotary knob, the character is confirmed. To add or delete characters, proceed to the following steps.

Entering the script name (adding and deleting characters)

4 Use the left and right cursor keys to select a character.

5 Press INS (SHIFT + the up cursor key).

A space is inserted at the cursor position.

If you press DEL (SHIFT + the down cursor key), the character at the cursor position is deleted.

6 Turn the rotary knob to select the character.

The space changes to the selected character. You can select ASCII code characters in the range of 0x20 to 0x7E. You can enter up to 15 characters. If you want to continue entering characters, repeat steps Procedure 4 to Procedure 6.

Editing Script2

● Press ENTER.

The screen for editing Script2 appears. The cursor moves to the CMD (command) column. Proceed with editing the script.

Editing Script2

```

SCRIPT EDIT
LINE CMD  PRG  LOOP
01 DO    P01   1
02 DO LOOP      2
03 DO    P02   1
04 DO    P03   1
05 END LOOP
06 DO    P04   1
-- END
    
```

Item	Input range or command syntax	Description
LINE	50 lines maximum	The lines contain the commands that make up the script.
DO	DO <Pn> <Loop> Pn: P01 to P16 Loop: 1 to 10000 or ∞ (infinity)	Repeat the program specified by its program number Pn ¹ until the count specified by Loop is reached.
DO LOOP END LOOP	DO LOOP <loop> to END LOOP Loop: 1 to 10000 or ∞ (infinity)	Repeat the sequence of commands that are enclosed in the loop's start (DO LOOP) and end (END LOOP) commands until the count specified by Loop is reached.

¹If the PBZ is currently in CV mode, select programs that were edited for CV mode. If the PBZ is currently in CC mode, select programs that were edited for CC mode.

When an error occurs because programs with modes that are different from the PBZ's CV/CC mode setting were executed

CV SCRIPT contains a program that was edited for CC mode

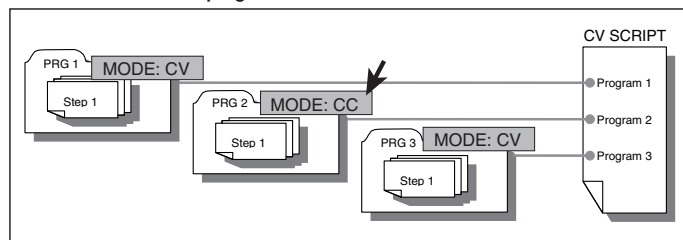

CC SCRIPT contains programs that were edited for CV mode

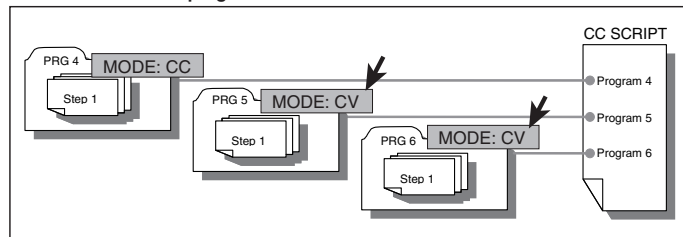

How to turn output off when a sequence completes

```

SCRIPT EDIT
LINE CMD  PRG  LOOP
01 DO    P01   1
02 DO LOOP      2
03 DO    P02   1
04 DO    P03   1
05 END LOOP
06 DO    P04   1
-- END
    
```

< 06 DO P05 1

Use a script to execute programs in a DO LOOP and then turn output off when a sequence completes. In the example shown in the figure above, program P05 contains a step that sets the OUTPUT setting to OFF. Program P05 is designed specifically to turn the output off. In this example, this program is added as the last program in the script.

Adding a line

- 1 Use the up and down cursor keys to select a line.**
- 2 Press INS (SHIFT + the up cursor key).**
A single line is inserted above the cursor position. The inserted line is set as follows: CMD is DO, PROG is P01, and LOOP is 1. If you press DEL (SHIFT + the down cursor key), the line at the cursor position is deleted.

Setting CMD (the command), PROG (the program), and LOOP (the number of times to repeat the command)

- 1 Use the left and right cursor keys to select the CMD column.**
- 2 Turn the rotary knob to select the command.**
You can set the command to DO, DO LOOP, or END LOOP.
- 3 Use the left and right cursor keys to select the PROG column.**
- 4 Turn the rotary knob to select the program number.**
The settable range is from P01 to P16.
If you are editing a CV SCRIPT, select programs that were edited for CV mode. If you are editing a CC SCRIPT, select programs that were edited for CC mode.
If you have selected DO LOOP or END LOOP for the CMD column, you cannot select a program for the PROG column.

NOTE

- When you are editing scripts, you can select any program to add to the script, independent of the CV/CC mode setting that was selected when the program was edited. If the CV/CC SCRIPT setting does not match the CV/CC mode setting of the PBZ, an error will be generated when you attempt to execute the script.
-

- 5 Use the left and right cursor keys to select the LOOP column.**
- 6 Turn the rotary knob to specify the number of times that the program will repeat.**
The input range is from 1 to 10000. You can also specify ∞ (infinity). If you fix the number that you specified using the rotary knob, the number is confirmed. If you have selected END LOOP for the CMD column, you cannot set the loop value.

Returning to editing Script1

- **Press EDIT (SHIFT + RUN/PAUSE).**
The screen for editing Script1 appears.

Finishing editing Script2

- **Press a key other than EDIT (SHIFT + RUN/PAUSE) or ENTER.**
Script2 editing completes, and the PBZ switches to the feature for the key that you pressed. The PBZ saves the edited script.

Executing Scripts

When a script is executed, the multiple programs that it contains are executed in the order specified in the script.

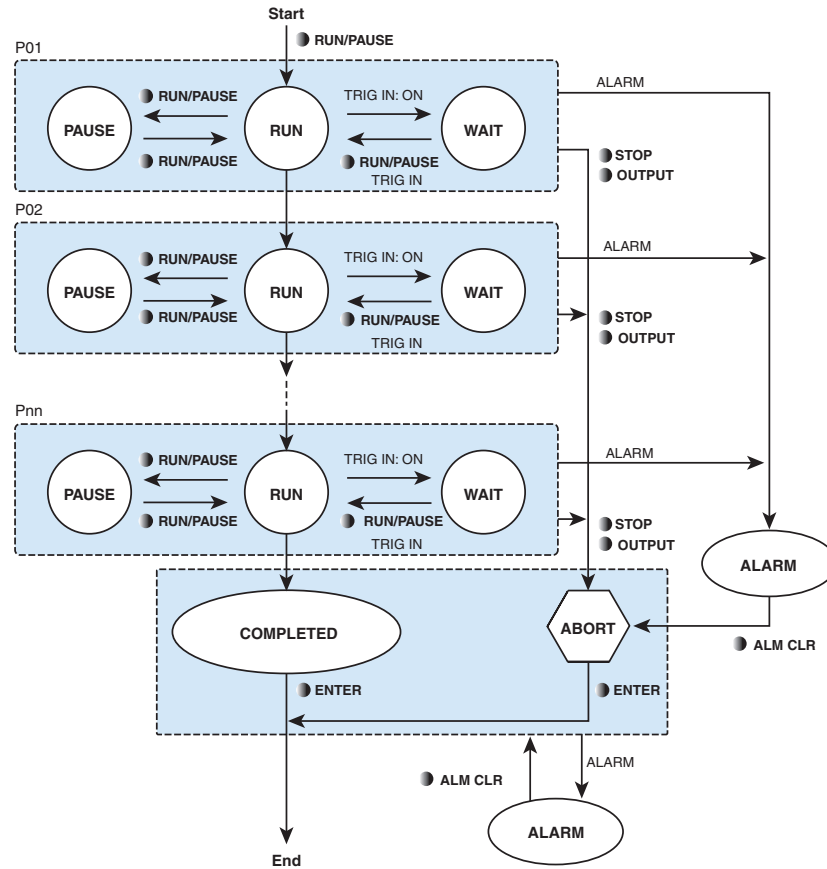

- Press RUN/PAUSE or STOP to make the PBZ enter the program execution (SEQ EXECUTION) state.
- Press RUN/PAUSE to start the execution.
- The programs in the script are executed according to the instructions in the script.
- If you press RUN/PAUSE, the execution is paused.
- If the program is designed to wait for a trigger signal, it enters the WAIT state.
- When all of the programs in the script complete, the PBZ enters the COMPLETED state.
- Press ENTER.
The PBZ returns to the state where you can set the DC signal (as if you had pressed the DC key).
- To abort execution, press STOP or OUTPUT. If you press OUTPUT, regardless of the programmed output settings, the output is turned off.
- If an alarm is generated, the PBZ enters the ALARM state.

Executing a Script (RUN)

1 Press RUN/PAUSE or STOP.

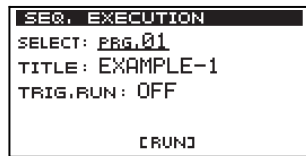

The sequence start screen (SEQ EXECUTION) appears. If you do not want to start program execution, press a key other than the RUN/PAUSE or STOP key.

2 Use the up and down cursor keys to select SELECT.

3 Turn the rotary knob to select the script to execute (CV SCRIPT or CC SCRIPT).

The script name is displayed next to TITLE.

If the PBZ is in CV mode, select CV SCRIPT. If the PBZ is in CC mode, select CC SCRIPT.

See p. 86

NOTE

- If this setting does not match the current CV/CC mode of the PBZ, an error will be generated when you execute the script.

4 Use the up and down cursor keys to select TRIG.RUN.

5 Turn the rotary knob to select ON or OFF.

If you select ON, execution will begin when a TRIG IN signal is applied. If you select OFF, execution will begin immediately after you press RUN/PAUSE. If you have used **CONFIG** to set OPERATION (synchronous operation) to SYNC SLAVE or SYNC SLAVE END, you cannot specify this setting. Instead of ON or OFF, “---” is displayed.

6 Press RUN/PAUSE.

The programs that the script contains are executed.

During execution, the program details are displayed. The RUN/PAUSE key is illuminated during execution.

See p. 89



PROG: The number of the program that is executing (from 1 to 16).

LOOP: The program's current loop number.

If this number exceeds 10000, “#####” is displayed.

STEP: The step number that is being executed (1 to 1024).

Time elapsed since the step began executing (hours : minutes : seconds).

When all of the programs in the script complete, the program completed screen (COMPLETED) appears. The RUN/PAUSE key turns off, and the STOP key illuminates.



7 Press ENTER.

The script finishes. The PBZ maintains the programmed output settings at the time when the script completed. The STOP key turns off, and the PBZ returns to the state where you can set the DC signal (as if you had pressed the DC key).

Operations Other than Script Execution

The following operations are carried out the same way as was explained in the section on programs.

 p. 114 ,
p. 115

- Aborting scripts (ABORT)
- Pausing scripts (PAUSE)
- Pausing scripts to wait for trigger input signals (WAIT)
- Remediating alarm generation
- Setting the protection features during script execution
- Setting the measurement feature during script execution

Program Examples

This section contains the following four program examples.

- Example 1: A DC signal
- Example 2: Superimposing an AC signal on a DC signal
- Example 3: Changing a DC signal using a trigger signal input
- Example 4: Generating an AC signal using a trigger signal input

See p. 99 , p. 112

For information on editing programs, see “Editing Programs and Steps”. For information on executing programs, see “Executing Programs”.

Example 1: A DC Signal

Program overview

In CV mode, this program changes the voltage of a DC signal over time. The program takes 0.2 seconds to change between voltages. The DC signal starts at 0 V, rises to 12.0 V (stays at this level for 1 second), rises to 14.0 V (stays at this level for 2 seconds), falls to 10.0 V (stays at this level for 3 seconds), and falls to 0 V (stays at this level for 0.6 seconds). The program will repeat this series of voltage changes until the process has been carried out 10 times.

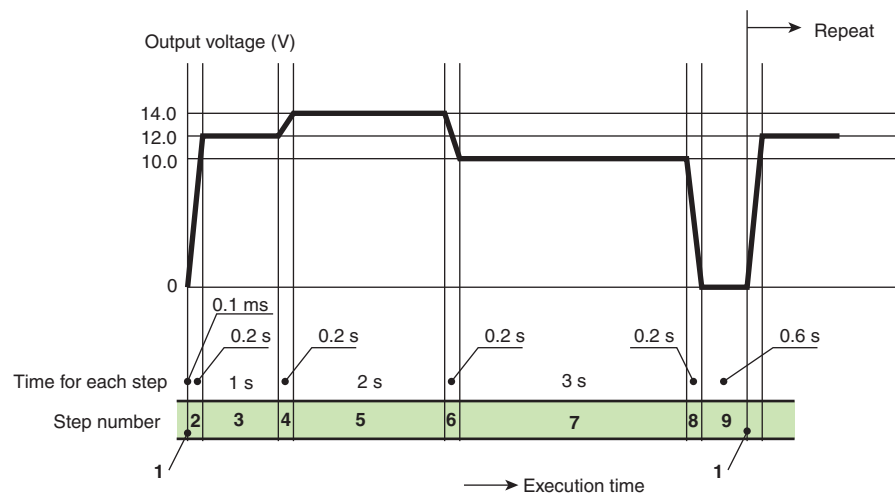

Editing steps

The basic pattern is broken up into 9 steps. Because the program needs to start from 0 V, the first step uses the minimum step execution time (0.1 ms) to set the DC signal to 0 V.

Item		Step details ("NA" means that the setting is not edited)								
STEP	Step number.	1	2	3	4	5	6	7	8	9
TIME	Step execution time.	0.1 ms	0.2 s	1 s	0.2 s	2 s	0.2 s	3 s	0.2 s	0.6 s
DC	DC signal.	0 V	12 V	12 V	14 V	14 V	10 V	10 V	0 V	0 V
DC RAMP	The DC signal ramps up or down gradually to the DC setting over time.	OFF	ON	OFF	ON	OFF	ON	OFF	ON	OFF
DC RAMP START	DC signal start value.	0 V	0 V	12 V	12 V	14 V	14 V	10 V	10 V	0 V
DC RAMP STOP	DC signal stop value.	0 V	12 V	12 V	14 V	14 V	10 V	10 V	0 V	0 V
OUTPUT	Output on/off state.	ON	ON	ON	ON	ON	ON	ON	ON	ON
TRIG OUT	Trigger signal output.	OFF	OFF	OFF	OFF	OFF	OFF	OFF	OFF	OFF
TRIG IN	Trigger signal input standby.	OFF	OFF	OFF	OFF	OFF	OFF	OFF	OFF	OFF
AC	Superimposition of AC signal on DC signal.	OFF	OFF	OFF	OFF	OFF	OFF	OFF	OFF	OFF
FUNC	AC signal waveform.	NA	NA	NA	NA	NA	NA	NA	NA	NA
AMPL	AC signal amplitude.	NA	NA	NA	NA	NA	NA	NA	NA	NA
FREQ	AC signal frequency.	NA	NA	NA	NA	NA	NA	NA	NA	NA
PHASE	AC signal start phase angle. The resolution is 1 deg.	NA	NA	NA	NA	NA	NA	NA	NA	NA
DUTY	Square wave duty ratio.	NA	NA	NA	NA	NA	NA	NA	NA	NA
AMPL SWEEP	AC signal amplitude sweep.	NA	NA	NA	NA	NA	NA	NA	NA	NA
AMPL START	Start and stop amplitudes for the AC signal amplitude sweep.	NA	NA	NA	NA	NA	NA	NA	NA	NA
AMPL STOP		NA	NA	NA	NA	NA	NA	NA	NA	NA
FREQ SWEEP	AC signal frequency sweep.	NA	NA	NA	NA	NA	NA	NA	NA	NA
FREQ MODE	AC signal frequency sweep mode.	NA	NA	NA	NA	NA	NA	NA	NA	NA
FREQ START	Start and stop frequencies for the AC signal frequency sweep.	NA	NA	NA	NA	NA	NA	NA	NA	NA
FREQ STOP		NA	NA	NA	NA	NA	NA	NA	NA	NA

Editing the program

Item		
PROG	Program number	A number from 1 to 16
TITLE	Program name	DC12LOOP10 (ASCII codes from 0x20 to 0x7E)
MODE	CV/CC mode	CV
LOOP	Number of repetitions	10

Example 2: Superimposing an AC Signal on a DC Signal

Program overview

In CV mode, this program varies the DC signal in a sawtooth fashion (from 6 V to 15 V), and superimposes a constant-amplitude (8 Vp-p) AC signal on the DC signal. The program repeats this series of voltage changes infinitely. The AC signal start phase is not specified.

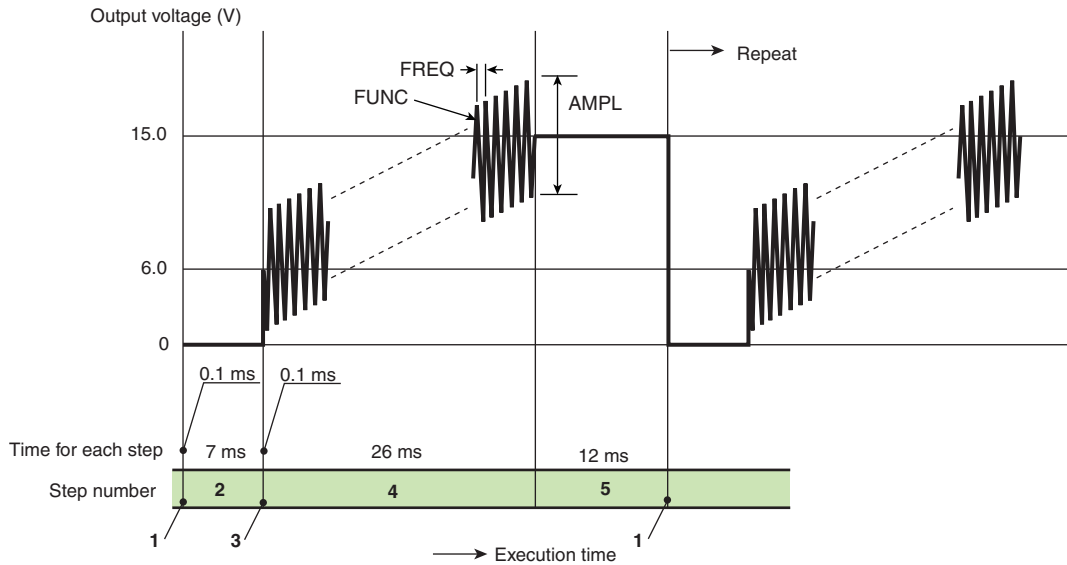

Editing steps

Item		Step details ("NA" means that the setting is not edited)				
STEP	Step number.	1	2	3	4	5
TIME	Step execution time.	0.1 ms	7 ms	0.1 ms	26 ms	12 ms
DC	DC signal.	0 V	0 V	6 V	15 V	15 V
DC RAMP	The DC signal ramps up or down gradually to the DC setting over time.	OFF	OFF	OFF	ON	OFF
DC RAMP START	DC signal start value.	0 V	0 V	0 V	6 V	15 V
DC RAMP STOP	DC signal stop value.	0 V	0 V	6 V	15 V	15 V
OUTPUT	Output on/off state.	ON	ON	ON	ON	ON
TRIG OUT	Trigger signal output.	OFF	OFF	OFF	OFF	OFF
TRIG IN	Trigger signal input standby.	OFF	OFF	OFF	OFF	OFF
AC	Superimposition of AC signal on DC signal.	OFF	OFF	OFF	ON	OFF
FUNC	AC signal waveform.	NA	NA	NA		NA
AMPL	AC signal amplitude.	NA	NA	NA	8 Vp-p	NA
FREQ	AC signal frequency.	NA	NA	NA	1 kHz	NA
PHASE	AC signal start phase angle. The resolution is 1 deg.	NA	NA	NA	FREE	NA
DUTY	Square wave duty ratio.	NA	NA	NA	NA	NA
AMPL SWEEP	AC signal amplitude sweep.	NA	NA	NA	NA	NA
AMPL START	Start and stop amplitudes for the AC signal amplitude sweep.	NA	NA	NA	NA	NA
AMPL STOP		NA	NA	NA	NA	NA
FREQ SWEEP	AC signal frequency sweep.	NA	NA	NA	NA	NA
FREQ MODE	AC signal frequency sweep mode.	NA	NA	NA	NA	NA
FREQ START	Start and stop frequencies for the AC signal frequency sweep.	NA	NA	NA	NA	NA
FREQ STOP		NA	NA	NA	NA	NA

Editing the program

Item		
PROG	Program number	A number from 1 to 16
TITLE	Program name	SAWTOOTH GEN (ASCII codes from 0x20 to 0x7E)
MODE	CV/CC mode	CV
LOOP	Number of repetitions	∞ (infinity)

Example 3: Changing a DC Signal Using a Trigger Signal Input

Program overview

In CV mode, this program changes the voltage of a DC signal over time and in sync with an external trigger signal. The program takes 0.2 seconds to change between voltages. The DC signal starts at 0 V, rises to 12.0 V, rises to 14.0 V, falls to 10.0 V, and falls to 0 V (stays at this level for 0.6 seconds). The program will repeat this series of voltage changes until the process has been carried out 10 times.

For each step, after the step execution time finishes, the PBZ maintains the specified voltage (12.0 V, 14.0 V, and 10.0 V) and waits for a trigger signal. The wait times are shown in the following figure as periods t2 to t3, t5 to t6, and t8 to t9. When a trigger signal is received, the next step begins, and the voltage changes. In period t7 to t8, the PBZ ignores any trigger signals that it receives.

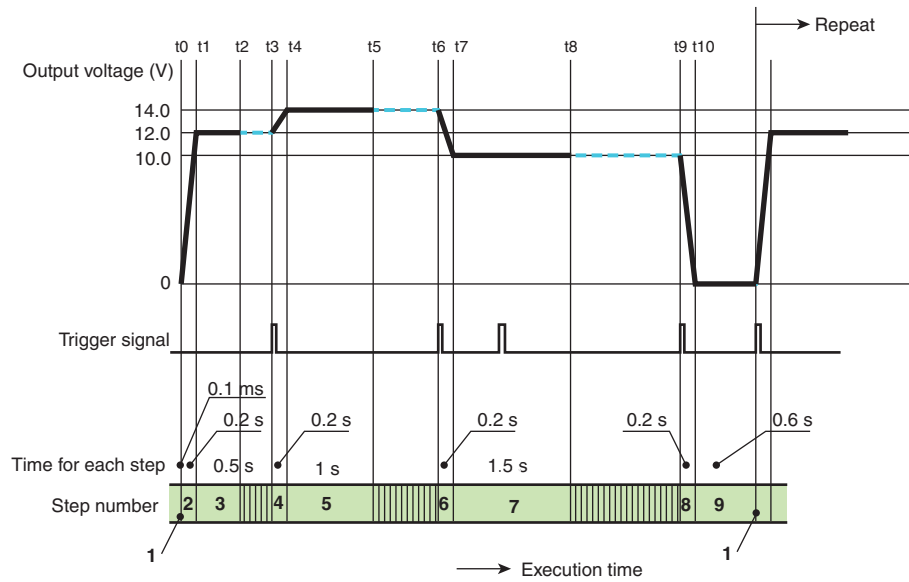

Editing the program

Item		Step details ("NA" means that the setting is not edited)								
STEP	Step number.	1	2	3	4	5	6	7	8	9
TIME	Step execution time.	0.1 ms	0.2 s	0.5 s	0.2 s	1 s	0.2 s	1.5 s	0.2 s	0.6 s
DC	DC signal.	0 V	12	12	14	14	10	10	0	0
DC RAMP	The DC signal ramps up or down gradually to the DC setting over time.	OFF	ON	OFF	ON	OFF	ON	OFF	ON	OFF
DC RAMP START	DC signal start value.	0 V	0 V	12 V	12 V	14 V	14 V	10 V	10 V	0 V
DC RAMP STOP	DC signal stop value.	0 V	12 V	12 V	14 V	14 V	10 V	10 V	0 V	0 V
OUTPUT	Output on/off state.	ON	ON	ON	ON	ON	ON	ON	ON	ON
TRIG OUT	Trigger signal output.	OFF	OFF	OFF	OFF	OFF	OFF	OFF	OFF	OFF
TRIG IN	Trigger signal input standby.	OFF	OFF	OFF	ON	OFF	ON	OFF	ON	OFF
AC	Superimposition of AC signal on DC signal.	OFF	OFF	OFF	OFF	OFF	OFF	OFF	OFF	OFF
FUNC	AC signal waveform.	NA	NA	NA	NA	NA	NA	NA	NA	NA
AMPL	AC signal amplitude.	NA	NA	NA	NA	NA	NA	NA	NA	NA
FREQ	AC signal frequency.	NA	NA	NA	NA	NA	NA	NA	NA	NA
PHASE	AC signal start phase angle. The resolution is 1 deg.	NA	NA	NA	NA	NA	NA	NA	NA	NA
DUTY	Square wave duty ratio.	NA	NA	NA	NA	NA	NA	NA	NA	NA
AMPL SWEEP	AC signal amplitude sweep.	NA	NA	NA	NA	NA	NA	NA	NA	NA
AMPL START	Start and stop amplitudes for the AC signal amplitude sweep.	NA	NA	NA	NA	NA	NA	NA	NA	NA
AMPL STOP		NA	NA	NA	NA	NA	NA	NA	NA	NA
FREQ SWEEP	AC signal frequency sweep.	NA	NA	NA	NA	NA	NA	NA	NA	NA
FREQ MODE	AC signal frequency sweep mode.	NA	NA	NA	NA	NA	NA	NA	NA	NA
FREQ START	Start and stop frequencies for the AC signal frequency sweep.	NA	NA	NA	NA	NA	NA	NA	NA	NA
FREQ STOP		NA	NA	NA	NA	NA	NA	NA	NA	NA

Editing the program

Item		
PROG	Program number	A number from 1 to 16
TITLE	Program name	TRIG DC12LOOP10 (ASCII codes from 0x20 to 0x7E)
MODE	CV/CC mode	CV
LOOP	Number of repetitions	10

Example 4: Generating an AC Signal Using a Trigger Signal Input

Program overview

In CV mode, this program generates single-shot signals according to trigger signals.

When this program begins execution, it waits for a trigger signal. When a trigger signal is received, the PBZ generates a signal that is the sum of a rectangular-shaped DC waveform (0 V to 15 V) and an AC signal whose amplitude is swept from 5 Vp-p to 8 Vp-p and whose frequency is swept from 80 Hz to 200 Hz. The AC signal start phase is 90°. The program repeats this series of voltage changes infinitely.

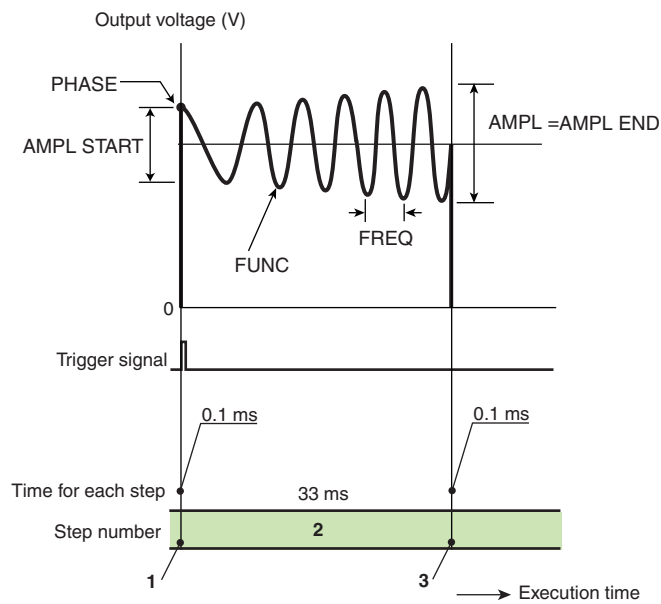

Editing the program

Item		Step details("NA" means that the setting is not edited)		
STEP	Step number.	1	2	3
TIME	Step execution time.	0.1 ms	33 ms	0.1 ms
DC	DC signal.	0 V	15 V	0 V
DC RAMP	The DC signal ramps up or down gradually to the DC setting over time.	OFF	OFF	OFF
DC RAMP START	DC signal start value.	0 V	15 V	0 V
DC RAMP STOP	DC signal stop value.	0 V	15 V	0 V
OUTPUT	Output on/off state.	ON	ON	ON
TRIG OUT	Trigger signal output.	OFF	OFF	OFF
TRIG IN	Trigger signal input standby.	ON	OFF	OFF
AC	Superimposition of AC signal on DC signal.	OFF	ON	OFF
FUNC	AC signal waveform.	NA		NA
AMPL	AC signal amplitude.	NA	8 Vp-p	NA
FREQ	AC signal frequency.	NA	200 Hz	NA
PHASE	AC signal start phase angle. The resolution is 1 deg.	NA	90 °	NA
DUTY	Square wave duty ratio.	NA	NA	NA
AMPL SWEEP	AC signal amplitude sweep.	NA	ON	NA
AMPL START	Start and stop amplitudes for the AC signal amplitude sweep.	NA	5 Vp-p	NA
AMPL STOP		NA	8 Vp-p	NA
FREQ SWEEP	AC signal frequency sweep.	NA	ON	NA
FREQ MODE	AC signal frequency sweep mode.	NA	LINEAR	NA
FREQ START	Start and stop frequencies for the AC signal frequency sweep.	NA	80 Hz	NA
FREQ STOP		NA	200 Hz	NA

Editing the program

Item		
PROG	Program number	A number from 1 to 16
TITLE	Program name	BURST AMFM (ASCII codes from 0x20 to 0x7E)
MODE	CV/CC mode	CV
LOOP	Number of repetitions	∞ (infinity)

Example 5: Performing a Ramp Transition That Takes Longer than 1 000 Seconds

This example shows the settings that you can use to perform a DC signal ramp transition or an AC signal amplitude sweep so that they exceed the length of time given in the specifications (1 000 seconds).

■ **DC RAMP: ON, AMPL SWEEP: OFF, FREQ SWEEP: OFF**

Performing a DC signal ramp transition from 0 V to 12 V over 1 hour (3600 seconds)

- 1** Divide the total ramp transition into a series of steps so that each step is 1000 seconds or less and the total execution time adds up to 3600 seconds.
- 2** Set the start value of each step to the end value of the previous step to make the steps continuous.

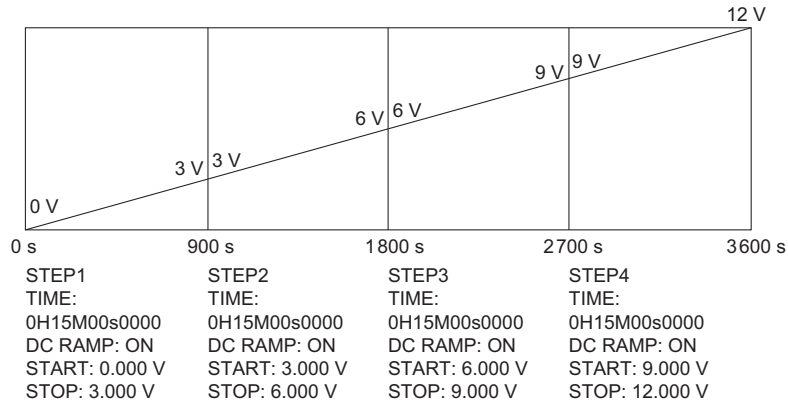



5

External Control, Parallel Operation, and Synchronization

This chapter explains external control, parallel operation, and synchronization.

External Control

By applying control signals to the rear panel J1 connector, you can control the following aspects of the PBZ. The J1 connector also generates status signals that indicate the PBZ's operating state.

- Controlling DC signals (the DC settings)
You can use external voltage or external resistance to control DC signals. In CV mode, you can control the voltage. In CC mode, you can control the current.
- Turning the OUTPUT terminal's output on and off
- Shutting down the PBZ
Turns the POWER switch off (trips the breaker).

About the J1 Connector

A protective socket is attached to the J1 connector when the PBZ is in the factory default state. When you use the J1 connector, remove the protective socket, and keep it in a safe place. To protect the connector pins, be sure to attach the protective socket when the J1 connector is not in use. If the protective socket is damaged or lost, contact your Kikusui agent or distributor.

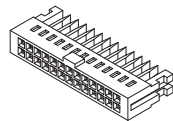

Protective socket [84-49-0110]



To avoid electric shock, observe the following precautions.

- **The J1 connector contains pins that have the same potential as the OUTPUT terminal. Be sure to attach the protective socket when the J1 connector is not in use.**
- **Be sure to put the protection cover on the socket.**

See p. 18

Pins, a socket, and a protection cover are included for connecting to the J1 connector. Simple IDC tools and contact removal tools are not included and must be purchased separately.

For information about how to obtain these tools or replacement parts, contact your Kikusui agent or distributor.

The following table contains tools and connector components that are necessary to connect the J1 connector. These tools and components are manufactured by OMRON Corporation.

Product	Model	OMRON corporation component code	Notes
Simple IDC tool	XY2B-7006	Y2-070-001	Not included.
Contact removal tool	XY2E-0001	Y2-070-002	Not included.
Pin (contact)	XG5W-0031	84-49-0100	Recommended wire size: AWG24 (UL-1061).
Socket	XG5M-2632-N	84-49-0160	MIL socket.
Protection cover (semi-cover)	XG5S-1301	84-49-0161	–

For information about how to use these tools and components, see the OMRON Corporation catalogs.

J1 connector pinout

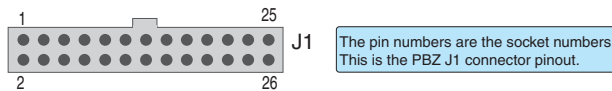

Pin no.	Signal name	Description
1	STATUS COMMON	Common for status outputs (pins 2, 4, 6, and 8) and option output (pin 5); isolated from ANALOG COMMON and DIGITAL COMMON.
2	ALARM STATUS	On when an alarm (OVP, OCP, or OHP) occurs (open-collector output from a photocoupler).
3	DIGITAL COMMON	Connected to the SHUT DOWN output (pin 7), the common terminal for OUTPUT ON/OFF signal input (pin 10), and the OUTPUT terminal's COM.
4	OUTPUT ON STATUS	On when output is on (open-collector output from a photocoupler).
5	OPTION	Option output (open-collector output from a photocoupler).
6	CC STATUS	On when the PBZ is in CC mode (open-collector output from a photocoupler).
7	SHUT DOWN	Signal input for shutting down the POWER switch. If an L TTL level signal is applied, or if this pin is shorted through the external contact, the POWER switch is turned off.
8	CV STATUS	On when the PBZ is in CV mode (open-collector output from a photocoupler).
9	CC MONITOR	In CC mode, this pin generates voltage that is proportional to the output current. For an output current of 0 A to \pm the rated value, this pin generates a voltage of 0 V to approximately ± 2 V.
10	OUTPUT ON/OFF	Receives the signal that is used to turn the OUTPUT terminal's output on and off. If a low TTL level signal (or a high signal if you use CONFIG to modify the PBZ settings) is applied or if this pin is shorted through the external contact (or if this pin is closed, depending on the settings), the OUTPUT terminal's output is turned off.
11	ANALOG COMMON	Common for the analog signals (pin 9 and pins 13 to 26); connected to the OUTPUT terminal's COM.
12	ANALOG COMMON	
13	CV MONITOR	In CV mode, this pin generates voltage that is proportional to the output voltage. For an output voltage of 0 V to \pm the rated value, this pin generates a voltage of 0 V to approximately ± 2 V.
14	N.C	
15	-REFERENCE	The same as pin 21.
16	N.C	
17	N.C	
18	ANALOG COMMON	Common for the analog signals (pin 9 and pins 13 to 26); connected to the OUTPUT terminal's COM.
19	+REFERENCE	The same as pin 25.
20	N.C	
21	-REFERENCE	Signal output for external resistance control of the DC signal (produced by the internal signal source). Approximately -10.8 V. Connected to the external resistor (10 k Ω across pins 21 and 25).
22	N.C	
23	REMOTE CONTROL INPUT	Signal input for external voltage control of the DC signal (produced by the internal signal source). The rated output can be controlled in the range of -100 % to +100 % using an input voltage in the range of -10 V to +10 V. Signal input for external resistance control of the DC signal (produced by the internal signal source). As the wiper that is connected to the external resistor (10 k Ω across pins 21 and 25) changes position from pin 21 to the center position, and then from the center position to pin 25, the rated output changes from -100 % to 0 % and then from 0 % to +100 %.
24	ANALOG COMMON	Common for the analog signals (pin 9 and pins 13 to 26); connected to the OUTPUT terminal's COM.
25	+REFERENCE	Signal output for external resistance control of the DC signal (produced by the internal signal source). Approximately +10.8 V. Connected to the external resistor (10 k Ω across pins 21 and 25).
26	N.C	

CAUTION • ANALOG COMMON and DIGITAL COMMON are connected internally to the OUTPUT terminal's COM. To ensure stable operation, do not connect both ANALOG COMMON and DIGITAL COMMON externally. Doing so could damage the PBZ.

Controlling DC Signals (The DC Settings)

See p. 87

You can control the DC signal by using voltages that are from 0 V to approximately ± 10 V or by using 10 k Ω variable resistors. Before using this function, you have to use **CONFIG** to change some settings. In the figure below, the signal source selection is set to "J1."

Using External Voltage

You can control the internal signal source's DC signal by using external voltage that is from 0 V to approximately ± 10 V. In CV mode, you can control the voltage. In CC mode, you can control the current. The output is equal to the sum of the setting that is determined by the external voltage and the DC settings that are set from the panel and remote control.

Connecting an external voltage

Connect an external voltage (Vext) as shown in the following figure.

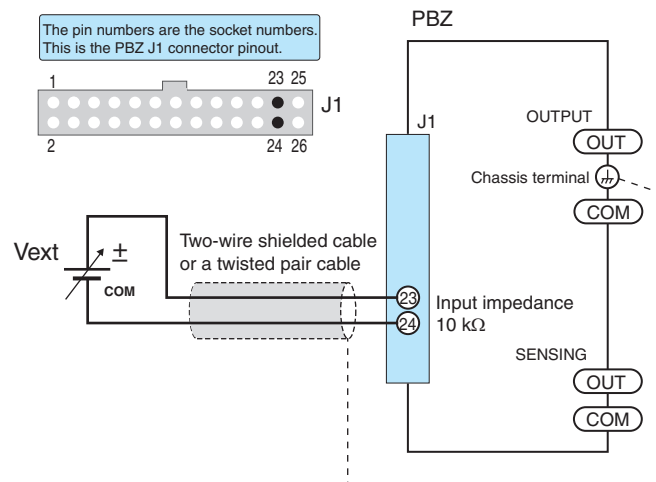

CAUTION • Do not apply a voltage of 10.5 V or greater across the external voltage control pins. Doing so could damage the PBZ.

Connect a low-noise, stable voltage source to Vext. To reduce the influence of noise on the output, connect a two-wire shielded cable or a twisted pair cable across Vext, and connect the voltage source so that it is as close to the PBZ as possible. If the wiring between the PBZ and the voltage source is long, it becomes easy for noise to influence the operation of the PBZ. Even if you use wires that are designed to suppress noise, the PBZ may not operate properly.

The relationship between control voltages and the output

The control range differs between bipolar and unipolar modes. For details, see "Using External Voltage (Control Signal J1)" on page 52.

Using External Resistance

You can control the internal signal source's DC signal by changing the reference voltage's voltage-divider ratio through the use of external variable resistors. In CV mode, you can control the voltage. In CC mode, you can control the current. The output is equal to the sum of the value that is determined by the external resistance and the DC values that are set from the panel and remote control.

Connecting an external resistor

Connect an external resistor (R_{ext}) as shown in the following figure. The arrow represents the wiper.

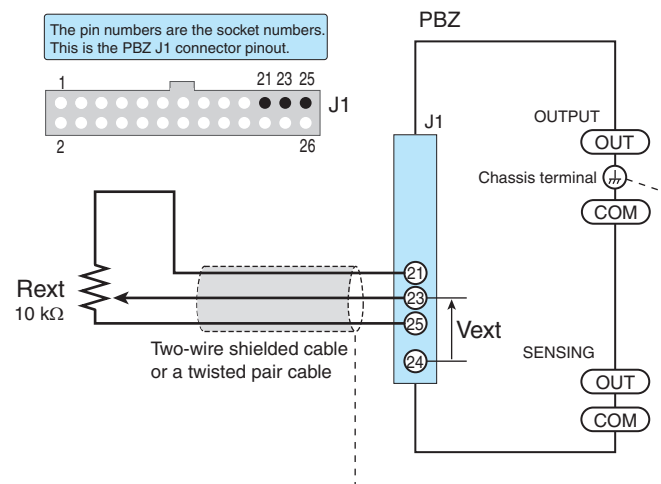

NOTE

- If you are switching between fixed resistors to control the PBZ, use a short-circuit type or continuous-type switch.

For R_{ext}, use a resistor that is rated at approximately 10 kΩ, 1/2 W or greater, that has a low temperature coefficient, and that will change little over time. Examples of such resistors are metal film or wire wound resistors. To reduce the influence of noise on the output, connect a two-wire shielded cable or a twisted pair cable across R_{ext}, and connect the resistor so that it is as close to the PBZ as possible. If the wiring between the PBZ and the resistor is long, it becomes easy for noise to influence the operation of the PBZ. Even if you use wires that are designed to suppress noise, the PBZ may not operate properly.

The relationship between the external resistance and the output

The control range differs between bipolar and unipolar modes. For details, see “Using External Resistance” on page 54.

Turning Output On and Off

Uses external control signals to turn the OUTPUT terminal's output on and off. You can also use switch contacts.

If you are using external control signals to turn the OUTPUT terminal's output off, you cannot use the panel's OUTPUT key or remote control to turn output on.

Connecting external contacts

Connect the external contact as shown in the following figure.

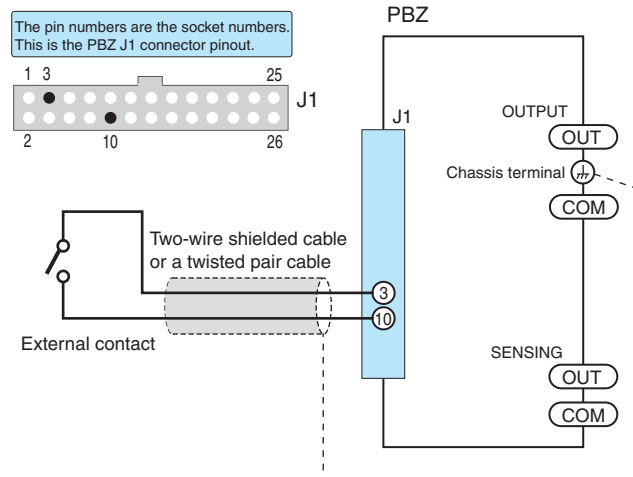

The maximum open-circuit voltage across pins 3 and 10 is approximately 5 V, and the short-circuit current is approximately 500 μ A (the internal circuits are pulled up to 5 V with 10 k Ω resistors). Use external contacts that have a contact rating of 0.5 mA at 5 VDC.

If two or more units are floating, and you are using a single external contact to turn output on and off for all the units, use a relay or similar device for the external contact signal to isolate the signal transmitted to each unit.

To reduce the influence of noise on the output, connect a two-wire shielded cable or a twisted pair cable across the external contact, and connect the contact so that it is as close to the PBZ as possible. If the wiring between the PBZ and the external contact is long, it becomes easy for noise to influence the operation of the PBZ. Even if you use wires that are designed to suppress noise, the PBZ may not operate properly.

The relationship between the contact signal and the OUTPUT terminal's output

When the output-on logic is HIGH:

OUTPUT terminal output	External control signal	External contact
ON	On the rising edge from low to high	Changes from make to break
OFF	Low	Make

You can also set the output-off logic to the opposite of the logic shown in the table above.

The relationship between the OUTPUT key and remote control

If you are using external control signals to turn the OUTPUT terminal's output off, you cannot use the panel's OUTPUT key or remote control to turn output on. The following figure shows the relationship between external control signals and the panel's OUTPUT key. In this example, the output-on logic is set to HIGH.

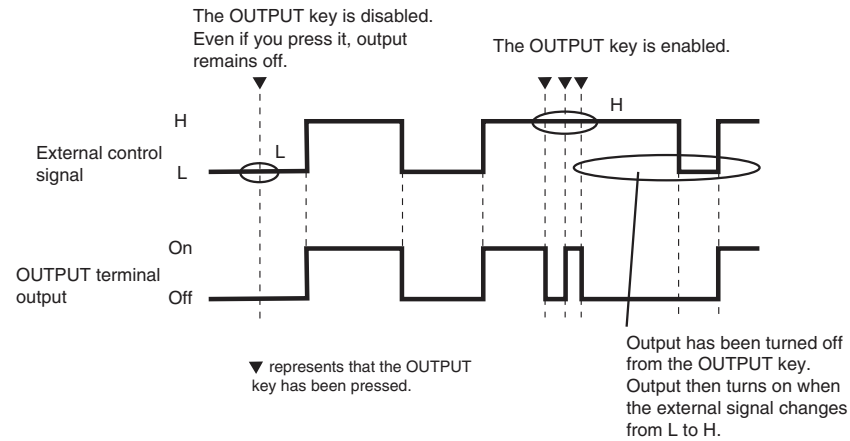

Shutting Down the PBZ

An external contact can be used to turn the POWER switch off (trip the breaker).

Connecting external contacts

Connect the external contact as shown in the following figure.

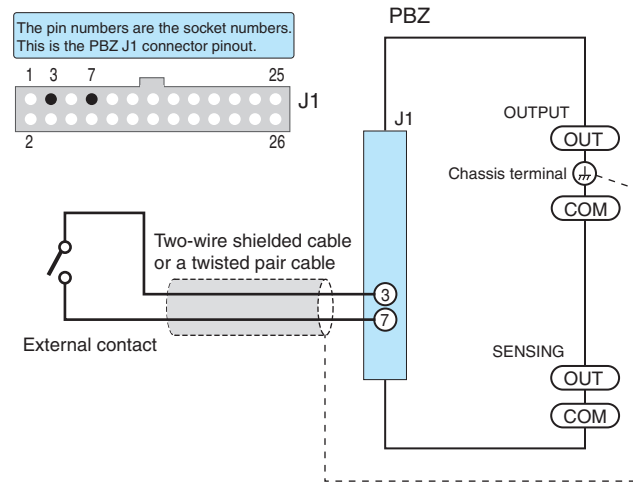

The maximum open-circuit voltage across pins 3 and 7 is approximately 5 V, and the maximum short-circuit current is approximately 500 μ A (the internal circuits are pulled up to 5 V with 10 k Ω resistors). Use external contacts that have a contact rating of 0.5 mA at 5 VDC. If two or more units are floating, and you are using a single external contact to turn output on and off for all the units, use a relay or similar device for the external contact signal to isolate the signal transmitted to each unit.

To reduce the influence of noise on the output, connect a two-wire shielded cable or a twisted pair cable across the external contact, and connect the contact so that it is as close to the PBZ as possible. If the wiring between the PBZ and the external contact is long, it becomes easy for noise to influence the operation of the PBZ. Even if you use wires that are designed to suppress noise, the PBZ may not operate properly.

The relationship between the contact signal and the POWER switch

POWER switch	External control signal	External contact
Off. (The breaker has tripped.)	LOW	Make

To turn the PBZ on, set the external control signal to HIGH, or break the external contact.

Signal Output

Status signals

Status signal output that enables you to externally monitor the PBZ's operating state. Each signal is an open-collector output from a photocoupler. STATUS COMMON is isolated from ANALOG COMMON and DIGITAL COMMON. The maximum ratings for each signal terminal are as follows:

- Maximum voltage: 30 V. Maximum current (sink): 8 mA.

Pin no.	Signal name	Operation (photocoupler output)	Circuit
8	CV STATUS	On in CV mode.	
6	CC STATUS	On in CC mode.	
4	OUTPUT ON STATUS	On when output is on.	
2	ALARM STATUS	On when an alarm (OVP, OCP, or OHP) is occurring.	
1	STATUS COMMON	Common for status outputs (pins 2, 4, 6, and 8) and option output (pin 5); isolated from the photocoupler emitter, ANALOG COMMON, and DIGITAL COMMON.	

Monitor signals

Voltage output that enables you to externally monitor the output voltage and output current.

Pin no.	Signal name	Description
13	CV MONITOR	Voltage output that is proportional to the output voltage measured at the load end of the sensing cable. For an output voltage of 0 V to \pm the rated value, this pin generates a voltage of 0 V to approximately ± 2 V.
9	CC MONITOR	Voltage output that is proportional to the current that the PBZ generates. For an output current of 0 A to \pm the rated value, this pin generates a voltage of 0 V to approximately ± 2 V.
11, 12	ANALOG COMMON	Monitor output common; connected to the OUTPUT terminal's COM.

Monitor signals during parallel operation

Pin no.	Signal name	Master unit	Slave unit
13	CV MONITOR	Voltage output that is proportional to the output voltage measured at the load end of the sensing cable. For an output voltage of 0 V to \pm the rated value, this pin generates a voltage of 0 V to approximately ± 2 V.	
9	CC MONITOR	Voltage output that is proportional to the current that the PBZ generates (the sum of the currents produced by all units operating in parallel). For an output current of 0 A to \pm (the rated value x the number of units in parallel operation), this pin generates a voltage of 0 V to approximately ± 2 V.	Voltage output that is proportional to the current that the PBZ slave unit generates. For an output current of 0 A to \pm the rated value, this pin generates a voltage of 0 V to approximately ± 2 V.
11, 12	ANALOG COMMON	Monitor output common; connected to the OUTPUT terminal's COM.	

Option output

General-purpose digital output that can only be set by communication commands (OUT:PORT). Each signal is an open-collector output from a photocoupler. STATUS COMMON is isolated from ANALOG COMMON and DIGITAL COMMON. The maximum ratings for each signal terminal are as follows:

- Maximum voltage: 30 V. Maximum current (sink): 8 mA.

Pin no.	Signal name	Operation (photocoupler output)	Circuit
5	OPTION	Set to on by an OUT:PORT ON (1) command.	
1	STATUS COMMON	Common for status outputs (pins 2, 4, 6, and 8) and option output (pin 5); isolated from the photocoupler emitter, ANALOG COMMON, and DIGITAL COMMON.	

Parallel Operation

You can magnify the PBZ's output current by connecting multiple units in parallel. In parallel operation, one unit is the master unit, and all other units connected in parallel are slave units. The master and slave units must all be the same model. Parallel operation of all the units is controlled from the master unit. Just like operating a single PBZ, you can use all the features that were explained in chapters 2 and 3. However, there are some special features and operations that can only be used during parallel operation. These features and operations are explained below. All features are set up from the master unit.

- **You must use the parallel operation kit (sold separately) when you perform parallel operation with two units**

By using the parallel operation kit, you can perform parallel operation with two PBZ units (the master unit and one additional slave unit). The parallel operation kit does not support parallel operation with three to five units (including the master unit). If you want to perform parallel operation with more than two PBZ units total, the units are installed in a smart rack for use. For details, contact your Kikusui agent or distributor.

Voltage display and current display

The master unit's ammeter displays the sum of the currents from all the connected PBZ units. The voltmeter displays the voltage that you specified. Slave units display their own output current.

Overcurrent protection

Overcurrent protection is configured from the master unit. The activation points take into account the number of units that are connected in parallel operation.

External monitoring

- External monitoring of the output current (I MON)

On the master unit, the output voltage is proportional to the sum of the currents produced by all units operating in parallel. For an output current of 0 A to \pm (the rated value \times the number of units in parallel operation), a voltage of 0 V to approximately ± 2 V is generated.

On slave units, the output voltage is proportional to the current that the slave unit itself generates. For an output current of 0 A to \pm the rated value, a voltage of 0 V to approximately ± 2 V is generated.

- Status monitoring (J1 connector)

From the master unit, you can monitor the status of CV mode (CV STATUS), CC mode (CC STATUS), output-on (OUTPUT ON STATUS), and alarm generation (ALARM STATUS).

From a slave unit, you can monitor the status of output-on (OUTPUT ON STATUS) and alarm generation (ALARM STATUS).

Using the Parallel Operation Kit

See p. 182

The parallel operation kit PK01-PBZ, PK02-PBZ and PK03-PBZ are designed to connect two PBZs (one master unit and one slave unit) in parallel. The PK01-PBZ is a kit designed to be used on a bench top. With this kit, the side panels of two PBZs are connected with dedicated brackets, and the OUTPUT terminals are connected together with dedicated connection bars. The PK02-PBZ (for inch racks) and the PK03-PBZ (for millimeter racks) are kits designed to be used on a rack. With this kit, two PBZs are rack mounted, and the OUTPUT terminals are connected together with dedicated connection bars.

Component and quantity

Component	PK01-PBZ	PK02-PBZ / PK03-PBZ
Insulation sheet	1	1

Component	PK01-PBZ	PK02-PBZ / PK03-PBZ
OUTPUT terminal connection bars	2	2
Screws for the load cables (M5-10L)	2	2
Parallel operation signal cable	1	1
Brackets	2	-
Screws for the brackets (M4-8L)	8	-
Parallel output terminal cover	1	-
Spacers	4	-

Installation

- 1** Decide which PBZ you will use as the master unit.
- 2** Turn the master and slave units off.
- 3** Install the master and slave units.

- **PK01-PBZ**

Attach brackets to the left and right sides.

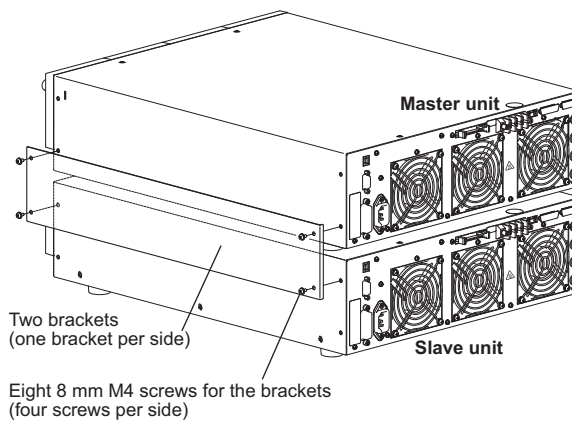

- **PK02-PBZ or PK03-PBZ**

Remove the feet from the bottom panels, attach rack mount brackets (KRB3-TOS or KRB150-TOS), and mount the PBZs on a rack.

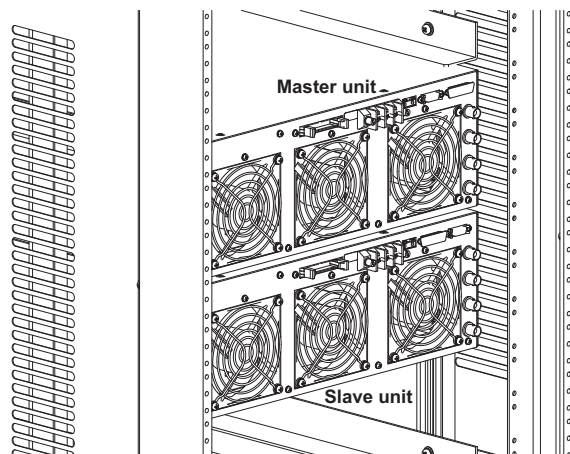

See p. 19, p. 181

Connection

See p. 27

To ensure stable operation, you must wire the load correctly. If the load is not wired correctly, the PBZ may exhibit unstable operation such as oscillation. Use the shortest cables possible to wire the load.

WARNING

To avoid electric shock, observe the following precautions.

- Turn the **POWER** switch off before you touch the **OUTPUT** terminals. Attach the **OUTPUT** terminal cover after you finish wiring the load.
- The **PK02-PBZ** and **PK03-PBZ** do not include covers for the **OUTPUT** terminal connection bars. Attach a cover to the back of the rack after you finish wiring the load.
- The rear panel may become hot during operation. If you touch it, you may burn yourself. Before you touch the rear panel, turn the **POWER** switch off, and allow a sufficient amount of time for the rear panel to become cool.

NOTE

- Be sure to connect the chassis terminals and the **COM** terminals with the short bars. If you do not, the **PBZs** may not meet their specifications.

- 1 Turn the master and slave units off.**
- 2 Remove the terminal covers from the master unit's rear panel PARALLEL terminal OUT and the slave unit's rear panel PARALLEL terminal IN.**

Keep these terminal covers in a safe place. When you are not using the **PBZs** in parallel operation, disconnect the parallel operation signal cable, and be sure to attach the terminal covers.
- 3 Use the parallel operation signal cable to connect the master unit's rear panel PARALLEL terminal OUT and the slave unit's rear panel PARALLEL terminal IN.**
- 4 Remove the OUTPUT terminal covers from the master and slave units.**

The **OUTPUT** terminal cover screws will be reused later.
- 5 Attach the OUTPUT terminal short bar between the chassis and COM terminals on both the master and slave units.**
- 6 Attach the Insulation sheet between the OUTPUT terminals, and then use the OUTPUT terminal connection bar to connect the OUT terminals. Connect the COM terminals in the same manner.**

Use the screws for the **OUTPUT** terminals.
- 7 Connect the load cables to the OUTPUT terminal connection bars.**

Use the screws for the load cables. The bar connected to the **OUT** terminals is "hot," and the bar connected to the **COM** terminals is common. Use load cables that have sufficient current capacity.
- 8 Attach the OUTPUT terminal covers to the master and slave units.**
- 9 For the PK01-PBZ, attach the parallel output terminal cover over the OUTPUT terminal connection bars.**

See p. 26

**For the PK02-PBZ or PK03-PBZ, attach a cover to the back of the rack.
(You must provide the cover yourself.)**

Enlarged view of the OUTPUT terminal

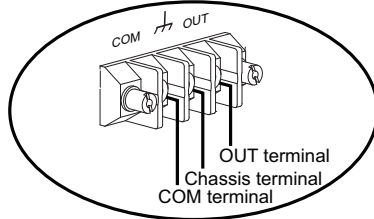

● **PK01-PBZ**

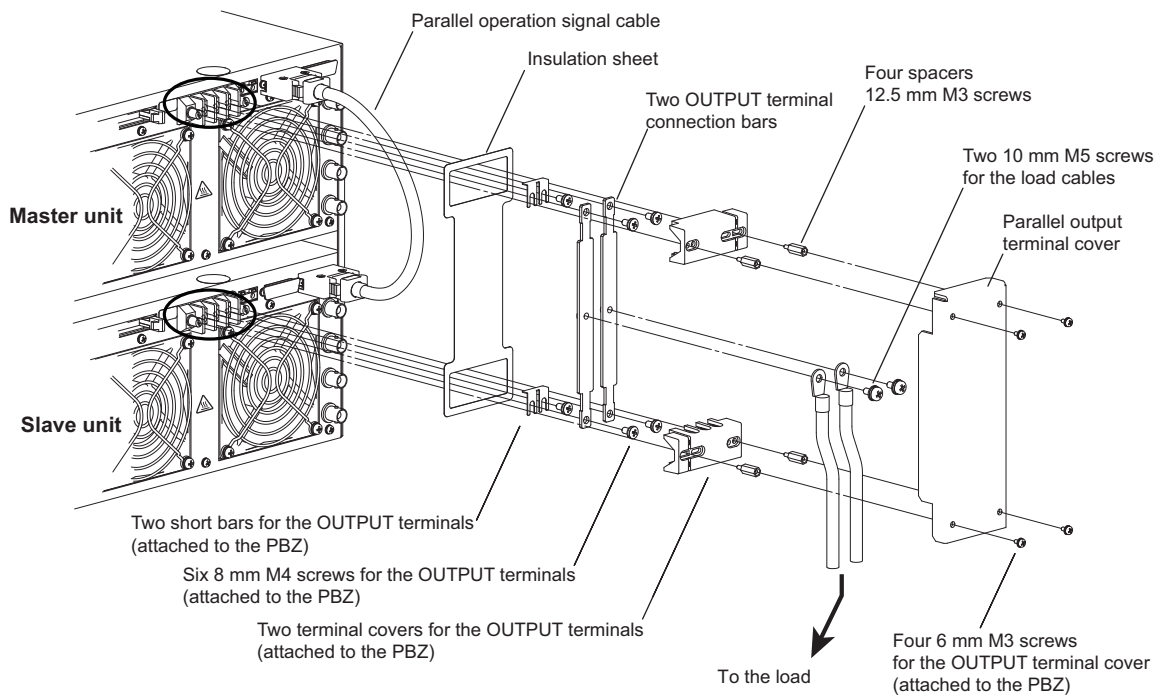

● **PK02-PBZ or PK03-PBZ**

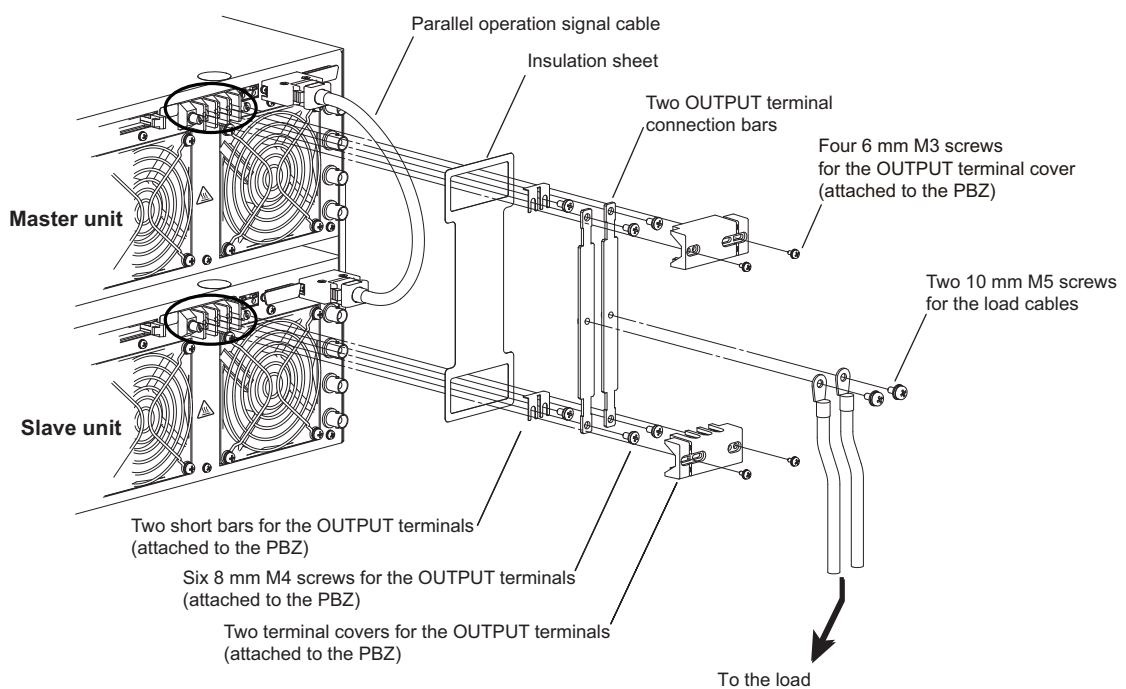

Remote Sensing

 p. 29

The PBZ can perform remote sensing. For information on connecting and setting remote sensing, see “Remote Sensing.”

Turning the POWER Switch On

- 1** Turn the slave unit’s POWER switch on.
- 2** Turn the master unit’s POWER switch on.

Specifying the Master Unit, the Slave Units, and the Number of Units in Parallel Operation

 p. 91

Use **CONFIG** to specify the master unit, the slave units, and the number of units in parallel operation. Set the master unit as the master unit; the slave units each as a slave unit; and the number of units in parallel operation to the total number of units, including the master unit (here, this number is two).

NOTE

- Be sure to set the number of units in parallel operation to the actual number of units that are connected. If this setting is incorrect, settings such as those for the overcurrent protection (OCP) cannot be set correctly, and the measured current is not displayed correctly.

Turning Output On and Off

Use the master unit’s OUTPUT key to turn output on and off.

Turning the POWER Switch Off

- 1** Turn the master unit’s POWER switch off.
- 2** Turn the slave unit’s POWER switch off.

 **CAUTION**

- After you turn the POWER switch off, wait at least 10 seconds after the fan stops before you turn the POWER switch back on. Turning the PBZ on too soon after you turn it off can cause damage to the inrush current limiter circuit, as well as reduce the life of components such as the POWER switch and the internal input fuses.

Synchronization Feature

By using the synchronization feature, you can:

- Turn the output of multiple units on and off at the same time.
- Synchronize sequence start timing across multiple units.
- Synchronize the clocks of multiple PBZs.

See p. 152

Output on/off synchronization and sequence start timing synchronization can be used at the same time as clock synchronization.

Connection Procedure

Connect coaxial cables to the rear panel TRIG IN and TRIG OUT terminals.

- Up to five slave units can be connected to the master unit's TRIG OUT terminal (see connection example 1).
- You can connect slave units to other slave units (see connection example 2).
- You can connect any unit from the PBZ series.
- Even if the master unit, slave units, and slave end units are operating in parallel, you can connect them for synchronization (by using the TRIG IN and TRIG OUT terminals of the master unit that is operating in parallel).

Connection example

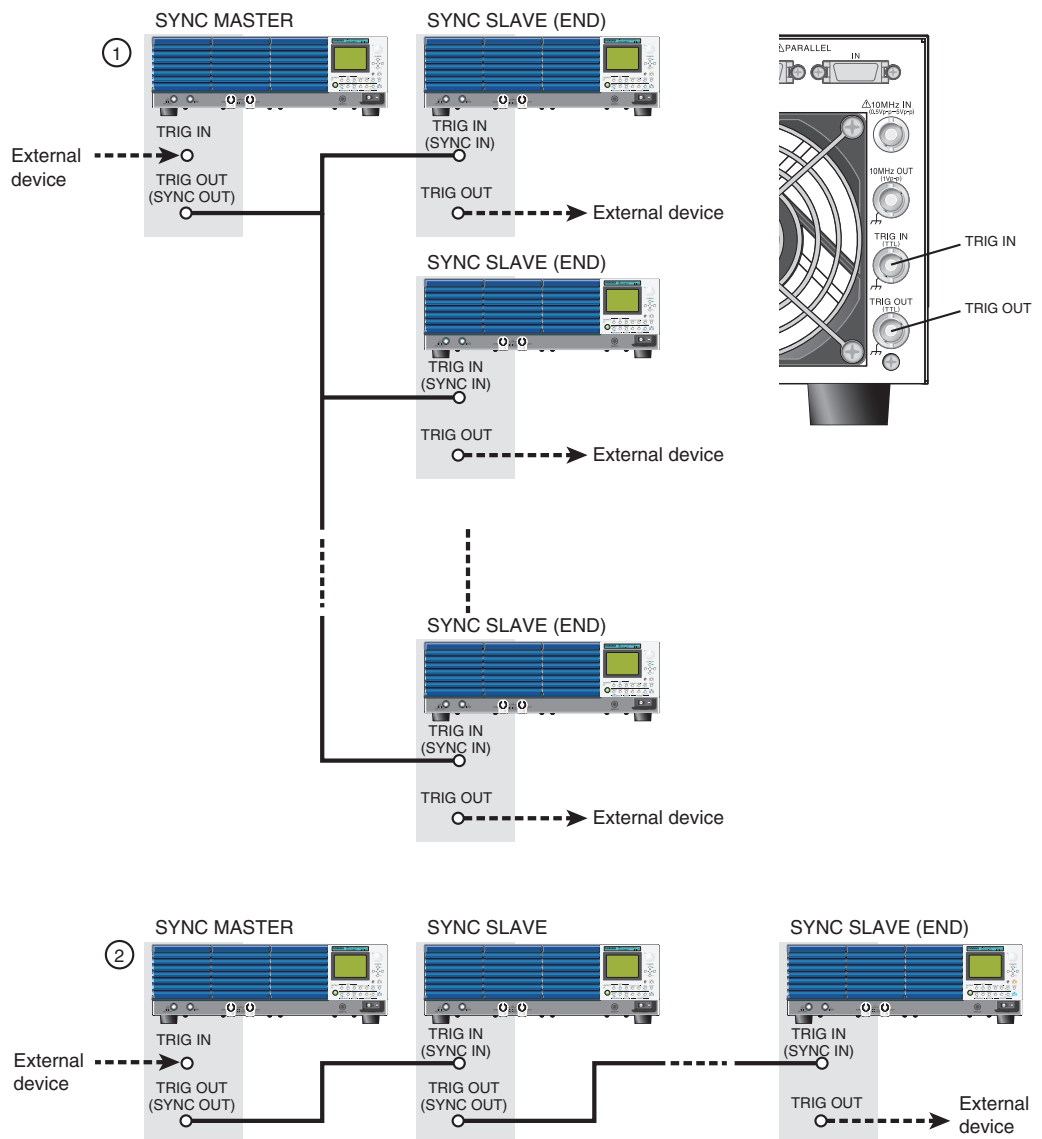

Configuring the Synchronization Feature

Set one unit as the master unit, and set the other units as either slave units or slave end units as the situation demands. Set units as slave end units if you want to use TRIG OUT signals.

You can connect any unit from the PBZ series.

- Master unit (SYNC MASTER)
- Slave unit (SYNC SLAVE)
- Slave end unit (SYNC SLAVE END)



 p. 89

Use **CONFIG** to set the synchronization feature. When output is on, you cannot change this setting.

The Functions of the TRIG IN and TRIG OUT Terminals

When the synchronization feature has been set

Depending on whether the unit is the master unit, a slave unit, or a slave end unit, the TRIG IN and TRIG OUT terminals function as trigger I/O (TRIG IN and TRIG OUT) or synchronization control signal I/O (SYNC IN and SYNC OUT).

Terminal	SYNC MASTER (master unit)	SYNC SLAVE (slave unit)	SYNC SLAVE END (slave end unit)
TRIG IN	Trigger input (TRIG IN)  p. 106	Synchronization control signal input (SYNC IN) ¹	Synchronization control signal input (SYNC IN) ¹
TRIG OUT	Synchronization control signal output (SYNC OUT) ¹	Synchronization control signal output (SYNC OUT) ¹	Trigger output (TRIG OUT)  p. 106

¹This terminal can only be used for this purpose.

CONFIG settings

The following limitations exist when PBZs have been connected and set for synchronization.

Function	SYNC MASTER (master unit)	SYNC SLAVE (slave unit)	SYNC SLAVE END (slave end unit)
TRIG IN	You can set the polarity.		You cannot select the polarity ("---" is displayed).
TRIG OUT	You cannot select the polarity ("---" is displayed).	You cannot select the polarity ("---" is displayed).	You can set the polarity.

Turning Output On and Off

By operating the master unit, you can turn the output on and off on all the units. If you operate a slave unit or a slave end unit, you can only turn the output off on that individual unit.

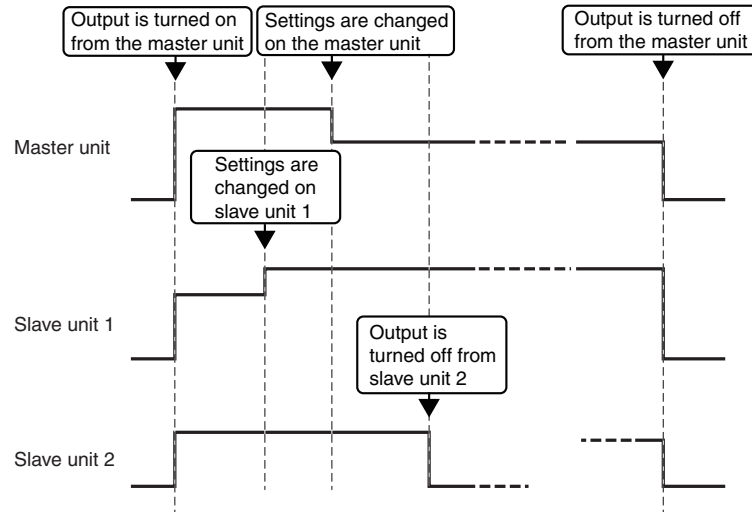

The following limitations exist when PBZs have been connected and set for synchronization.

Function	SYNC MASTER (master unit)	SYNC SLAVE (slave unit) SYNC SLAVE END (slave end unit)
OUTPUT on	Possible	Not possible ¹
OUTPUT off	Possible	Possible

¹When you try to turn the output on, the error "W005: SYNC SLAVE state" is displayed.

Turning Output On when the POWER Switch Is Turned On

Follow the procedure below to synchronize and turn on output on the master and slave units when the master unit's POWER switch is turned on.

See p. 87

Use the POWER ON > OUTPUT setting in **CONFIG** to set this feature. To set POWER ON > OUTPUT to ON, you have to set POWER ON > SEQ RUN to OFF.

- 1** Turn the slave unit's POWER switch on.
- 2** Turn the master unit's POWER switch on.

Setting the Signal Source

The following limitations exist when PBZs have been connected and set for synchronization.

DC signal source settings

Setting	SYNC MASTER (master unit)	SYNC SLAVE (slave unit) SYNC SLAVE END (slave end unit)
DC	Can be set	Can be set
FINE		
SOFT START	Can be set	Can be set
SOFT STOP	Can be set	Cannot be set (fixed to OFF) ¹

¹When you try to set this setting, the error "W005: SYNC SLAVE state" is displayed.

AC signal source settings

Setting	SYNC MASTER (master unit)	SYNC SLAVE (slave unit) SYNC SLAVE END (slave end unit)
AC ON/OFF		Cannot be set. ¹ (It can only be set to OFF.)
FUNC		Can be set. ²
AMPL	Can be set	
FREQ		Cannot be set. ¹ (It can only be set when output is off.)
PHASE		
DUTY		Can be set.
SWEEP	Cannot be set (Set to OFF)	Cannot be set. ¹ (Set to OFF.)

¹When you try to set this setting, the error "W005: SYNC SLAVE state" is displayed.

²If you change the slave unit settings when output is on, the phase relationship with the master unit is cleared. To reset this phase relationship, on the master unit, you have to turn OUTPUT off and back on again or change the AC ON/OFF setting to OFF and then change it to ON.

Executing Sequences

By operating the master unit, you can execute sequences on all the units. Sequence execution will not start on any slave units that do not have a sequence selected.

■ Sequence execution start procedure overview

- 1 Press RUN/PAUSE or STOP on all the slave units.**
The sequence start screen appears.
- 2 On the sequence start screen, select the program number or the script that you want to execute.**
Select the program number or script on each slave unit.
- 3 Press RUN/PAUSE or STOP on the master unit.**
The sequence start screen appears.
- 4 On the sequence start screen, select the program number or the script that you want to execute.**
- 5 Press RUN/PAUSE on the master unit.**
Sequences start at the same time on the master unit and on all slave units that have a sequence selected.

The following limitations exist when PBZs have been connected and set for synchronization.

Function	SYNC MASTER (master unit)	SYNC SLAVE (slave unit) SYNC SLAVE END (slave end unit)
RUN	Possible (Starts execution on all synchronized units)	Not possible ¹
PAUSE	Possible	Possible
STOP		

¹When you try to execute sequences, the error "W005: SYNC SLAVE state" is displayed.

Clock Synchronization

Connect coaxial cables to the rear panel reference clock I/O terminals (10 MHz IN and 10 MHz OUT terminals). Regardless of whether the units are set to operate synchronously or not, you can synchronize the clocks of all PBZ series units as well as synchronize the clocks of PBZs with the clocks of external devices. When the internal clocks of all units are synchronized:

- All units have the same frequency accuracy.
- The specified phase relationships of the AC signals of all units are maintained.
- All units have the same sequence execution time accuracy.
- If all units execute the same sequence, they all change steps at the same time.

Connection example

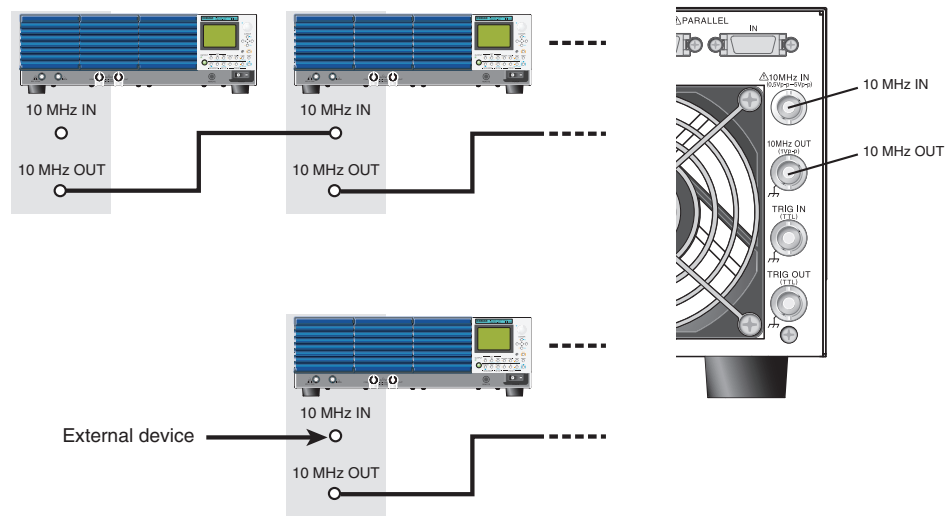

If a signal that exceeds the frequency range that is listed in the specifications is applied to the 10 MHz IN terminal, the following screen (10 MHz UNLOCKED) may appear. If this happens, the PBZ's clock is out of sync with the external devices.





6

Maintenance

This chapter describes how to clean and inspect the PBZ.

Cleaning and Inspection

Periodic inspection is essential to maintain the initial performance of the PBZ over an extended period.

Check for tears in the power cord insulation and breaks in the terminal block.



Tears in the power cord's insulation may cause electric shock or fire. If a tear is found, stop using the damaged power cord.

To purchase accessories or options, contact your Kikusui agent or distributor.

Cleaning the dust filter

A dust filter is installed on the inside of the louver on the front panel. Periodically clean the filter to prevent clogging.



- A clogged filter hinders the cooling of the inside of the PBZ, can cause malfunctions, and can shorten the PBZ's service life.
- When the PBZ is in operation, air is sucked through the dust filter to cool the inside of the device.
If moisture is present in the dust filter, the temperature or humidity inside the PBZ increases and may cause malfunctions.

- 1 Place your thumb on the second row from the bottom of the louver. While pulling the bottom row towards you, pull down, and remove the louver from the panel.**

If the louver is difficult to remove, press down on the top row, and the louver should be easy to remove.

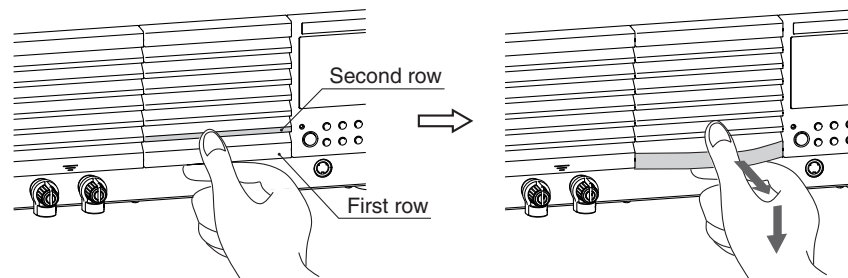

- 2 Remove the dust filter from the inside of the louver and clean it.**

Use a vacuum cleaner to dispose of the dust and foreign particles that are attached to the dust filter. If the filter is extremely dirty, clean it using a water-diluted neutral detergent and dry it completely.

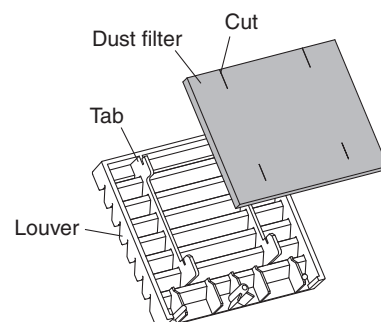

- ⚠ CAUTION** • When the PBZ is in operation, air is sucked through the dust filter to cool the inside of the device. If moisture is present in the dust filter, the temperature or humidity inside the PBZ increases and may cause malfunctions.

3 Attach the dust filter to the louver.

Attach the dust filter so that the louver's tabs pass through the cuts in the dust filter.

4 Hold the second row of the louver and pull it up until the pin is fixed in place to attach the louver to the panel.

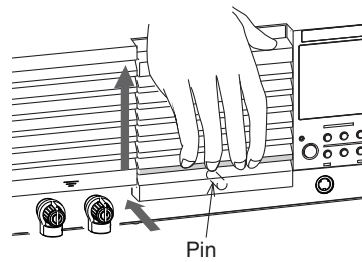

Backup Battery Replacement

The PBZ has a battery inside. The battery's service life differs depending on the environment that the PBZ is used in, but three years after it is purchased is a rough estimate for the battery's service life. For information about replacing the battery, contact your Kikusui agent or distributor.

This page is intentionally blank.



7

Specifications

This chapter contains the specifications and gives the dimensions of the PBZ.

Unless specified otherwise, the specifications are for the following settings and conditions.

- The warm-up time is 30 minutes (with current flowing).
- TYP: These are typical values that are representative of situations where the PBZ operates in an environment with an ambient temperature of 23 °C. These values do not guarantee the performance of the PBZ.
- rtg: Indicates the rated voltage or current.
- setting: Indicates a setting.
- rdng: Indicates the readout value of a measured result.
- rtg/CF: The rated voltage or rated current divided by CF (crest factor).
- The polarity of the output voltage and current is defined as follows.
 - Voltage: Using the output's COM terminal as a reference, the voltage is positive (+) when the OUT terminal is positive and negative (-) when the OUT terminal is negative.
 - Current: Positive (+) when current flows out from the OUT terminal and negative (-) when current flows into the OUT terminal.
- The output specifications apply to the rear panel output terminals under the following conditions:
 - The short bar is used to connect the output's COM terminal and chassis terminal.
 - Remote sensing is not being performed.
 - The auxiliary output terminals may not meet the specifications.
- Loads are purely resistive loads.
- Rated loads are defined as follows:
 - When the PBZ is generating its rated voltage, the load causes the rated current to flow.
 - Or, when the PBZ is generating its rated current, the load makes the voltage drop to the PBZ's rated voltage.

AC Input

Item	PBZ20-20	PBZ40-10	PBZ60-6.7	PBZ80-5
Nominal input rating	100 Vac to 240 Vac, 50 Hz to 60 Hz			
Input voltage range	90 Vac to 250 Vac			
Input frequency range	47 Hz to 63 Hz			
Current	10 Aac or less (when connected to a rated load)			
Inrush current	40 Apeak or less			
Power	900 VA or less (when connected to a rated load)			
Power factor	0.95 TYP (when the input voltage is 100 V and when connected to a rated load)			

Rated Output

Item	PBZ20-20	PBZ40-10	PBZ60-6.7	PBZ80-5	
Rating	Output power	400 W		402 W	400 W
	Output voltage	±20 V	±40 V	±60 V	±80 V
	Output current	±20 A	±10 A	±6.7 A	±5 A
	Isolation voltage ¹	500 Vdc			

¹Only the output's COM terminal can be grounded.

CV Mode Output

Item			PBZ20-20	PBZ40-10	PBZ60-6.7	PBZ80-5	
DC voltage	Settable range ¹	Bipolar mode	0.000 V to ±21.000 V	0.000 V to ±42.000 V	0.000 V to ±63.000 V	0.000 V to ±84.000 V	
		Unipolar mode	0.000 V to 21.000 V	0.000 V to 42.000 V	0.000 V to 63.000 V	0.000 V to 84.000 V	
		Fine feature	±5 % of rtg				
	Resolution	0.001 V (0.0001 V for the fine feature)		0.002 V (0.0002 V for the fine feature)			
	Accuracy ²	± (0.05 % of setting + 0.05 % of rtg)					
	Temperature coefficient	±100 ppm/°C of rtg (TYP)					
AC voltage	Settable range ¹		0.00 Vpp to 42.00 Vpp	0.0 Vpp to 84.0 Vpp	0.0 Vpp to 126.0 Vpp	0.0 Vpp to 168.0 Vpp	
	Resolution		0.01 V	0.1 V			
	Accuracy ³		±0.5 % of rtg				
AC frequency	Settable range		0.01 Hz to 100.00 kHz				
	Resolution		0.01 Hz				
	Accuracy		±200 ppm				
	Sweep		Linear and logarithmic				
	Sweep time		100 µs to 1000 s (resolution of 100 µs)				
AC waveform	Type		Sine wave, square wave, triangle wave, and 16 user-defined arbitrary waveforms				
	Start phase		0 ° to 359 °				
	Square wave duty cycle		0.1 % to 99.9 % (f < 100 Hz), 1 % to 99 % (100 Hz ≤ f < 1 kHz), 10 % to 90 % (1 kHz ≤ f < 10 kHz), and fixed to 50 % (10 kHz < f)				
Constant voltage characteristics	Frequency response ⁴		DC to 100 kHz (TYP)				
	Response ^{5, 6}		3.5 µs (TYP) 10 µs (TYP) 35 µs (TYP) 100 µs (TYP)				
	Overshoot		5 % or less (TYP)				
	Ripple noise	(p-p) ⁷		20 mV (TYP)		30 mV (TYP)	
		(rms) ⁸		2 mV (TYP)	4 mV (TYP)		
	Load effect ⁹		±(0.005 % of setting + 1 mV)				
	Source effect ¹⁰		±(0.005 % of setting + 1 mV)				

¹The peak value of the sum of the DC voltage and AC voltage is limited by the DC voltage's settable range.

²At an ambient temperature between 18 °C and 28 °C.

³At an ambient temperature between 18 °C and 28 °C, with a 1 kHz sine wave, 3.5 µs response, and no load.

⁴A frequency where the amplitude ratio of the output voltage to the external signal input voltage is -3 dB (when the reference frequency is 1 kHz, the response is 3.5 µs, and when a rated load is connected).

⁵The rise or fall time (at rated load; excluding when output is turned on and off). The frequency response is based on the specified response setting (frequency bandwidth = 0.35/the rise time).

⁶Rise time: The time it takes for the output voltage to rise from 10 % to 90 % of the rating when the output voltage is changed from 0 V to the rated voltage.

Fall time: The time it takes for the output voltage to fall from 90 % to 10 % of the rating when the output voltage is changed from the rated voltage to 0 V.

⁷The measurement frequency bandwidth is 10 Hz to 20 MHz (at the output terminals).

⁸The measurement frequency bandwidth is 10 Hz to 1 MHz (at the output terminals).

⁹The change in the output voltage in response to a change in the output current from 0 % to 100 % of the current rating (measured at the sensing terminals when remote sensing is used).

¹⁰The change in the output voltage in response to a ±10% change in the input voltage in reference to the nominal input voltage (measured at the sensing terminals when remote sensing is used).

CC Mode Output

Item			PBZ20-20	PBZ40-10	PBZ60-6.7	PBZ80-5
DC current	Settable range ¹	Bipolar mode and unipolar mode	0.000 A to ±21.000 A	0.000 A to ±10.500 A	0.000 A to ±7.035 A	0.000 A to ±5.250 A
		Fine feature	±5 % of rtg			
	Resolution		0.001 A (0.0001 A for the fine feature)			
	Accuracy ²		±0.3 % of rtg			
	Temperature coefficient		±100 ppm/°C of rtg (TYP)			
AC current	Settable range ¹		0.00 App to 42.00 App	0.00 App to 21.00 App	0.00 App to 14.07 App	0.00 App to 10.50 App
	Resolution		0.01 A			
	Accuracy ³		±0.5 % of rtg			
AC frequency	Settable range		0.01 Hz to 100.00 kHz			
	Resolution		0.01 Hz			
	Accuracy		±200 ppm			
	Sweep		Linear and logarithmic			
	Sweep time		100 µs to 1000 s (resolution of 100 µs)			
AC waveform	Type		Sine wave, square wave, triangle wave, and 16 user-defined arbitrary waveforms			
	Start phase		0 ° to 359 °			
	Square wave duty cycle		0.1 % to 99.9 % (f < 100 Hz), 1 % to 99 % (100 Hz ≤ f < 1 kHz), 10 % to 90 % (1 kHz ≤ f < 10 kHz), and fixed to 50 % (10 kHz < f)			
Constant current characteristics	Frequency response ⁴		DC to 10 kHz (TYP)	DC to 5 kHz (TYP)	DC to 10 kHz (TYP)	
	Response ^{5, 6}		35 µs (TYP)	70 µs (TYP)	35 µs (TYP)	
	Overshoot		5 % or less (TYP)			
	Ripple noise	(rms) ⁷	3 mA (TYP)			
	Load effect ⁸		±(0.01 % of setting + 1 mA)			
	Source effect ⁹		±(0.01 % of setting + 1 mA)			

¹The peak value of the sum of the DC current and AC current is limited by the DC current's settable range.

²At an ambient temperature between 18 °C and 28 °C.

³At an ambient temperature between 18 °C and 28 °C, with a 100 Hz sine wave, 35 µs response, and shorted output.

⁴A frequency where the amplitude ratio of the output current to the external signal input voltage is -3 dB (when the reference frequency is 100 Hz, the response is 35 µs, and a rated load is connected). The frequency response changes according to the load impedance. When the load impedance increases, the frequency response decreases.

⁵The rise or fall time (at rated load; excluding when output is turned on and off). The rise and fall times change according to the load impedance.

⁶Rise time: The time it takes for the output current to rise from 10 % to 90 % of the rating when the output current is changed from 0 A to the rated current.

Fall time: The time it takes for the output current to fall from 90 % to 10 % of the rating when the output current is changed from the rated current to 0 A.

⁷The measurement frequency bandwidth is 10 Hz to 1 MHz (when the output voltage is in the range of 10 % to 100 % of the rated output voltage).

⁸The change in the output current in response to a change in the output voltage from 10 % to 100 % of the voltage rating.

⁹The change in the output current in response to a ±10% change in the input voltage in reference to the nominal input voltage (when the output voltage is in the range of 10 % to 100 % of the voltage rating).

Measurement Display Feature

Item			PBZ20-20	PBZ40-10	PBZ60-6.7	PBZ80-5
Voltage measurement	DC	Measurement range (resolution)	±120 % of rtg (0.001 V)			
		Accuracy ¹	± (0.05 % of rdng + 0.05 % of rtg)			
		Temperature coefficient	±100 ppm/°C of rtg (TYP)			
	AC	Measurement range (resolution)	±120 % of rtg/CF (0.001 V)			
	DC+AC	Measurement range (resolution)	120 % of rtg (0.001 V)			
	AC and DC+AC	Accuracy ^{1, 2}	±(0.5 % of rdng + 0.1 % of rtg) in the range of 5 Hz to 10 kHz			
			±(1 % of rdng + 0.2 % of rtg) in the range of 10 kHz to 50 kHz			
	±(2 % of rdng + 0.2 % of rtg) in the range of 50 kHz to 100 kHz					
PEAK	Measurement range (resolution)	±120 % of rtg (0.01 V)				
PEAK	Accuracy ^{1, 3}	±0.5 % of rtg				
Current measurement	DC	Measurement range (resolution)	±120 % of rtg (0.001 A)			
		Accuracy ¹	±(0.3 % of rdng + 0.1 % of rtg)			
		Temperature coefficient	±150 ppm/°C of rtg (TYP)			
	AC	Measurement range (resolution)	120 % of rtg/CF (0.001 A)			
	DC+AC	Measurement range (resolution)	120 % of rtg (0.001 A)			
	AC and DC+AC	Accuracy ^{1, 2}	±(3 % of rdng + 0.1 % of rtg) in the range of 5 Hz to 10 kHz			
			±(10 % of rdng + 1 % of rtg) in the range of 10 kHz to 100 kHz			
PEAK	Measurement range (resolution)	±120 % of rtg (0.01 A)				
PEAK	Accuracy ^{1, 3}	±0.5 % of rtg				
Measurement time			100 μs to 3600 s			

¹At an ambient temperature between 18 °C and 28 °C.

²When the input signal is in the frequency range, the AC signal is a sine wave that has a crest factor of 3 or less, and the measurement time is at least 10 times the input signal period.

³Peak value of a 1 kHz sine wave.

Protection Features

Item		PBZ20-20	PBZ40-10	PBZ60-6.7	PBZ80-5
Overvoltage protection	Protection operation ^{1, 2}	OVP or V-LIMIT (output limit). Select whether output or the POWER switch turns off when OVP is activated.			
	Settable ranges (Bipolar mode)	Select whether $(-110\% \text{ of rtg} \leq -V.LIM \leq +V.LIM \leq +110\% \text{ of rtg})$ or $(-110\% \text{ of rtg} \leq -OVP \leq -1\% \text{ of rtg}, +1\% \text{ of rtg} \leq +OVP \leq +110\% \text{ of rtg})$			
	Settable range (Unipolar mode)	Select whether $-1\% \text{ of rtg} \leq -V.LIM \leq +V.LIM \leq +110\% \text{ of rtg}$ or $+1\% \text{ of rtg} \leq +OVP \leq +110\% \text{ of rtg}$			
	Resolution	0.01 V			
	Accuracy	$\pm 1\% \text{ of rtg}$			
Overcurrent protection	Protection operation	OCP or I-LIMIT (output limit). Select whether output or the POWER switch turns off when OCP is activated.			
	Settable ranges	Select wheter $(-110\% \text{ of rtg} \leq -I.LIM \leq -1\% \text{ of rtg}, +1\% \text{ of rtg} \leq +I.LIM \leq +110\% \text{ of rtg})$ or $(-110\% \text{ of rtg} \leq -OCP \leq -1\% \text{ of rtg}, +1\% \text{ of rtg} \leq +OCP \leq +110\% \text{ of rtg})$			
	Resolution	0.01 A			
	Accuracy	$\pm 1\% \text{ of rtg}$			
Overheat protection	Protection operation	Turns output off when overheating is detected.			
Power limit (sink power)	Bipolar mode	100 W (TYP)	180 W (TYP)	200 W (TYP)	
	Unipolar mode	400 W (TYP)		402 W (TYP)	400 W (TYP)

¹Voltage is detected at the output terminals.

²OVP is activated even when V-LIMIT (voltage limit) is selected. The OVP activation point is approximately $\pm 120\%$ of rtg.

Control Feature

Item		PBZ20-20	PBZ40-10	PBZ60-6.7	PBZ80-5
Internal signal source's DC signal control	Control voltage input	By applying approximately 0 V to approximately ± 10.0 V, you can generate 0 % to $\pm 100\%$ of the rated output.			
	Control voltage ratio input	By using a 10 k Ω external variable resistor to change the internal reference voltage's voltage-divider ratio, you can generate 0 % to $\pm 108\%$ of the rated output.			
Output on/off control input		External contact input to turn output on and off.			
Shutdown input		External contact input to turn the POWER switch off.			
Status output		CV/CC mode, output on, alarm occurrence			

Signal I/O

Item			PBZ20-20	PBZ40-10	PBZ60-6.7	PBZ80-5		
External signal input	Amplifier gain	CV mode	-20.00 to +20.00	-40.0 to +40.0	-60.0 to +60.0	-80.0 to +80.0		
		CC mode	-20.00 S to +20.00 S	-10.00 S to +10.00 S	-6.70 S to +6.70 S	-5.00 S to +5.00 S		
		Resolution	0.01 V (CV mode) 0.01 S (CC mode)	0.1 V (CV mode) 0.01 S (CC mode)				
		Accuracy ¹	±5 % of rtg					
	Maximum allowable input voltage		±12 V _{peak}					
	Input impedance		10 kΩ (TYP)					
	Terminal		BNC safety socket. (Common is connected to the output's COM terminal.)					
Current monitor output	Output voltage		2 V with the rated current					
	Output voltage accuracy		±1 % of rtg (TYP)					
	Output voltage frequency response		DC to 20 kHz					
	Terminal		BNC safety socket. (Common is connected to the output's COM terminal.)					
Clock input	Input voltage		0.5 V _{p-p} to 5 V _{p-p}					
	Input impedance		1 kΩ TYP (AC coupling)					
	Lockable frequency range		10 MHz ± 200 Hz					
	Lock time		2 s or less					
	Terminal		Isolated BNC. (Common is isolated from the chassis; the maximum isolation voltage is 42 V _{peak} .)					
Clock output	Output voltage		1 V _{p-p} TYP (when terminated with 50 Ω)					
	Output impedance		50 Ω TYP (AC coupling)					
	Output frequency		10 MHz ± 200 Hz					
	Terminal		BNC. (Common is connected to the chassis.)					
Trigger input	Input level		H level: 2 V to 5 V. L level: 0 V to 0.8 V (TTL compatible)					
	Polarity		H level and L level					
	Pulse width		1 μs or more					
	Delay		1 μs or less					
	Input impedance		10 kΩ TYP (DC coupling)					
	Terminal		BNC. (Common is connected to the chassis.)					
Trigger output	Output level		H level: 2.7 V to 5 V. L level: 0 V to 0.4 V (TTL compatible)					
	Polarity		H level and L level					
	Pulse width		10 μs (TYP)					
	Rise time and fall time		100 ns or less					
	Fan-out		Five units from the PBZ series					
	Terminal		BNC. (Common is connected to the chassis.)					

¹When the amplifier gain is at maximum and the PBZ is generating DC.

Interface

Item		PBZ20-20	PBZ40-10	PBZ60-6.7	PBZ80-5
Common specifications	Software protocol	IEEE Std 488.2-1992			
	Command language	Complies with SCPI Specification 1999.0			
RS232C	Hardware	Complies with the EIA232D specifications			
		D-SUB 9-pin connector (male) ¹			
		Baud rate: 1200, 2400, 4800, 9600, 19200, and 38400 bps			
		Data length: 7 bits or 8 bits. Stop bit: 1 bit or 2 bits. Parity bit: None.			
	Flow control: X-flow or none.				
	Program message terminator	LF during reception, LF during transmission			
GPIB	Hardware	Complies with IEEE Std 488.1-1987			
		SH1, AH1, T6, L4, SR1, RL1, PP0, DC1, DT1, C0, and E1			
	24-pin connector (receptacle)				
	Program message terminator	LF or EOI during reception, LF + EOI during transmission			
	Primary address	1 to 30			
USB	Hardware	Complies with the USB 2.0 specifications. Data rate: 12 Mbps (full speed).			
		Socket B type			
	Program message terminator	LF or EOM during reception, LF + EOM during transmission			
	Device class	Complies with the USBTMC-USB488 device class specifications			
LAN (factory option)	Hardware	IEEE 802.3 100Base-TX/10Base-T Ethernet			
		Complies with the LXI 1.4 Core 2011			
		IPv4, RJ-45 connector ²			
	Communication protocol	VXI-11, SCPI-RAW			
	Program message terminator	LF or END during reception, LF + END during transmission			

¹Use a cross cable (null modem cable).

²Category 5; use a straight cable.

Other Features

Item		PBZ20-20	PBZ40-10	PBZ60-6.7	PBZ80-5
Sequence feature	Number of programs and number of steps	16 programs and total of 1024 steps			
	Step time	100 µs to 1000 h (resolution of 100 µs) The DC signal ramp and AC signal amplitude sweep both stop after 1000 s. The AC signal frequency sweep repeats once every 1000 s.			
Preset memory		3 memory entries			
Setup memory		10 memory entries			
Key lock		Select one of three security levels			
Remote sensing		Can be turned on and off			
Power-on operation		Turn output on or begin execution of the sequence feature			
Soft start and soft stop		Can be turned on and off. Soft start and soft stop time: 0.1 ms to 1000 s.			
Parallel operation		On up to two same-model PBZs (using the optional parallel operation kit)			

General

Item		PBZ20-20	PBZ40-10	PBZ60-6.7	PBZ80-5
Weight		Approx. 22 kg (48.50 lb; just the PBZ)			
Dimensions		See the outline drawing.			
Environmental conditions	Operating environment	Indoor use, overvoltage category II			
	Operating temperature	0 °C to +40 °C (+32 °F to +104 °F)			
	Operating humidity	20 %rh to 85 %rh (no condensation)			
	Storage temperature	-25 °C to +70 °C (-13 °F to +158 °F)			
	Storage humidity	90 %rh or less (no condensation)			
	Altitude	Up to 2000 m			
Grounding polarity		Only the output's COM terminal can be grounded.			
Isolation voltage		500 Vdc max			
Withstand voltage	Across the primary circuit and chassis	No abnormalities at 1500 Vac for 1 minute			
	Across the primary circuit and the output terminals				
Insulation resistance	Across the primary circuit and chassis	500 Vdc, 30 MΩ or greater (at 70 %rh humidity or less)			
	Across the primary circuit and the output terminals				
	Across the output terminals and chassis	500 Vdc, 1 MΩ or greater (at 70 %rh humidity or less)			
Earth continuity	Power cord inlet, across the earth pin and chassis	25 Aac, 0.1 Ω or less			
Cooling method		Forced air cooling using variable-speed, heat-sensitive fan			
Safety ¹		Complies with the requirements of the following standards. Low Voltage Directive 2014/35/EU EN 61010-1 (Class I ² , Pollution degree 2 ³)			
Electromagnetic compatibility (EMC) ¹		Complies with the requirements of the following standard. EMC Directive 2014/30/EU EN 61326-1 (Class A ⁴) EN 55011 (Class A ³ , Group 1 ⁵) EN 61000-3-2 EN 61000-3-3 Applicable condition All of the cables and wires connected to the PBZ are less than 3 m in length.			
Accessories	Power cord		1 pc.		
	J1 connector	Socket	1 pc.		
		Protection covers	2 pairs		
		Pins	30 pc.		
	Heavy object warning label		1 pc.		
	CD-ROM		1 pc.		
Operation manual		Setup guide 1 pc., Quick reference English 1pc., Japanese 1pc. Safety information 1pc.			

¹Does not apply to specially made or modified PBZs.

²This is a Class I equipment. Be sure to ground this product's protective conductor terminal. The safety of this product is only guaranteed when the product is properly grounded.

³Pollution is addition of foreign matter (solid, liquid or gaseous) that may produce a reduction of dielectric strength or surface resistivity. Pollution Degree 2 assumes that only non-conductive pollution will occur except for an occasional temporary conductivity caused by condensation.

⁴This is a Class A equipment. This product is intended for use in an industrial environment. This product may cause interference if used in residential areas. Such use must be avoided unless the user takes special measures to reduce electromagnetic emissions to prevent interference to the reception of radio and television broadcasts.

⁵This is a Group I equipment. This product does not generate and/or use intentionally radio-frequency energy, in the form of electromagnetic radiation, inductive and/or capacitive coupling, for the treatment of material or inspection/analysis purpose.

Dimensions

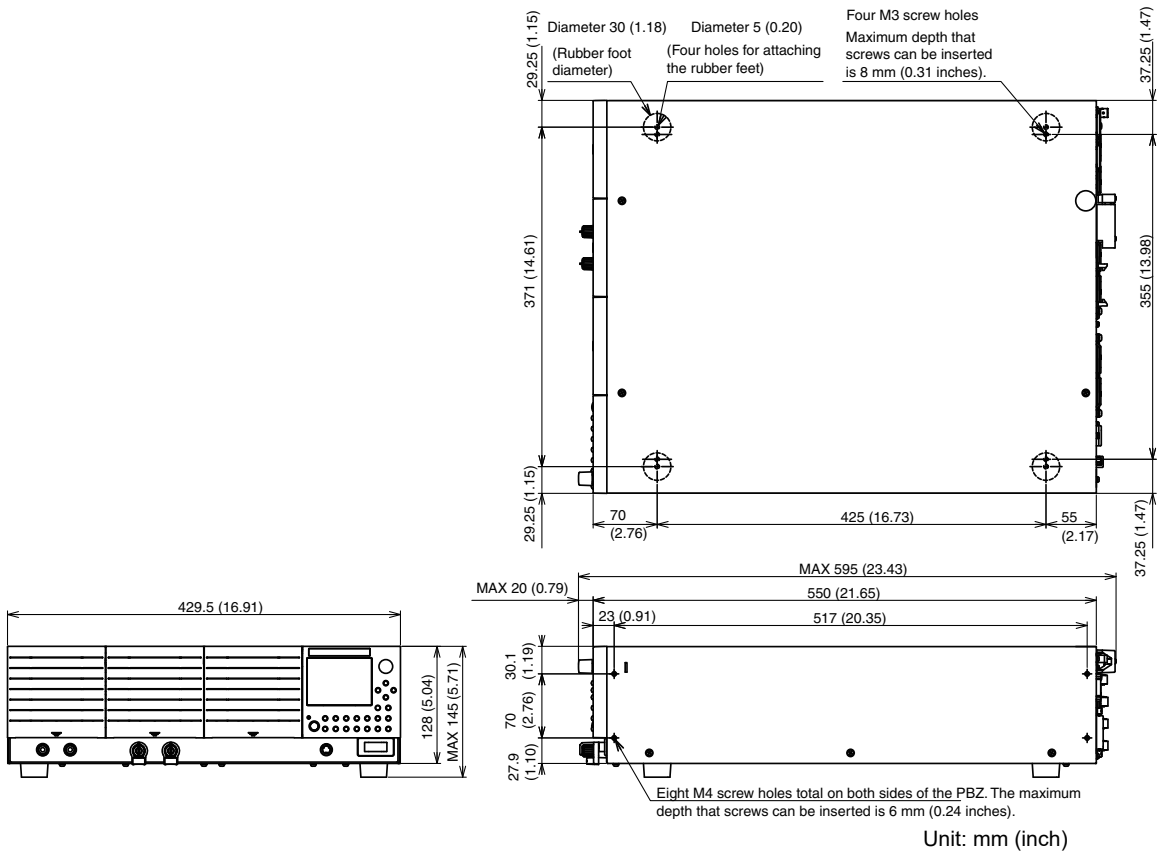



Appendix

- A List of Factory Default Settings
- B Output impedance
- C Troubleshooting
- D List of Error Messages
- E Options

A List of Factory Default Settings

Resetting the PBZ to its default values

If you hold down the SHIFT key while you turn the POWER switch on, the PBZ starts up with the factory default settings. Continue holding down the SHIFT key until the initial screen is displayed.

Operation mode and signal sources

Item			Factory default setting
Operation mode	CONTROL	CV/CC mode	CV
	POLARITY	Bipolar/unipolar mode	BIPOLAR
Signal source selection	SELECT	Internal, external, and addition	INT
	EXT SELECT	External signal source	BNC
External signal input (BNC terminal)	EXT GAIN	Gain	0 (not inverted)
DC signal	DC	DC	CV: 0 V CC: 0 A
	FINE	Fine adjustment of the DC setting	CV: 0 V and CC: 0 A
	SOFT START SOFT STOP	Soft start time Soft stop time	OFF
AC signal	FUNC	Waveform	SIN (sine wave)
	AMPL	Amplitude	CV: 0 V _{p-p} CC: 0 A _{p-p}
	FREQ	Frequency	1000 Hz
	PHASE	Start phase	0 deg
	DUTY	Square wave duty cycle	50 %
	AC	AC signal: on/off	OFF
	SWEEP	Frequency sweep: on/off	OFF
	MODE	Sweep mode	LINEAR
	TIME	Sweep time	1 s
	START	Sweep start frequency	100 Hz
	STOP	Sweep stop frequency	1000 Hz
	TRIG OUT	TRIG OUT terminal: on/off	OFF
	MARKER FREQ	Marker frequency	500 Hz
	Response	VOLT	CV mode
CURR		CC mode (PBZ20-20/ PBZ60-6.7/ PBZ80-5)	35 μs
		CC mode (PBZ40-10)	70 μs
Remote sensing	SENSING		OFF

Output

Item			Factory default setting
Power-on operation	STATE	State of settings	LAST
	OUTPUT	Output state	OFF
	SEQ RUN	Sequence execution	OFF
Trigger signal	TRIG IN	Trigger signal input polarity	POS
	TRIG OUT	Trigger signal output polarity	POS
External contact	POLARITY	Output-on logic	HIGH

Protection features and protection activation points

Item			Factory default setting
Overvoltage	VOLT	Action.	LIMIT
Overcurrent	CURR	Action.	LIMIT
Protection operation	OVP/OCP ACTION	The protective action that is carried out when OVP or OCP is activated.	OUT OFF
Activation points	+I.LIM/+OCP	Positive current activation point.	110 % of the rated value
	-I.LIM/-OCP	Negative current activation point.	
	+V.LIM/+OVP	Positive voltage activation point.	
	-V.LIM/-OVP	Negative voltage activation point.	

Measurement function

Item			Factory default setting
Measurement	FUNC	Measurement function selection	DC
	APERTURE	Measurement time	0 s
	TRIG SOURCE	Measurement start trigger	AUTO
	TRIG DELAY	Delay	0 s

Preset memory



Item			Factory default setting ¹
DC signal (CV or CC mode)	DC	Voltage or current	0 V or 0 A
	FINE	Fine adjustment of the DC setting	0 V or 0 A
AC signal (CV or CC mode)	ON/OFF	AC signal on/off state	OFF ²
	FUNC	Waveform	 Sine wave ²
	AMPL	Amplitude	0 V or 0 A
	FREQ	Frequency	1000 Hz ²
	PHASE	Start phase	0 deg ²
	DUTY	Square wave duty cycle	50 % ²

¹The same in all three memory entries (A, B, and C).

²The same in both CV mode and CC mode.

If you use **CONFIG** to change settings to DEFAULT (the default values), memory is not affected. If you reset the PBZ to its factory default settings, all the memory entries are cleared. (This manual differentiates between the terms “default values” and “factory default settings.”)

Setup memory

Item			Factory default setting ¹
DC signal	DC	Voltage or current	0 V
	FINE	Fine adjustment of the DC setting	0 V
	SOFT START SOFT STOP	Soft start time Soft stop time	OFF
AC signal	ON/OFF	AC signal on/off state	OFF
	FUNC	Waveform	 Sine wave
	AMPL	Amplitude	0 V
	FREQ	Frequency	1000 Hz
	PHASE	Start phase	0 deg
	DUTY	Square wave duty cycle	50 %
AC signal frequency sweep	SWEEP	Whether sweeps are executed or not	OFF
	MODE	Sweep mode	LINEAR
	TIME	Sweep time	1 s
	START	Start frequency	100 Hz
	STOP	Stop frequency	1000 Hz
	TRIG OUT	TRIG OUT terminal: on/off	OFF
	MARKER FREQ	Marker frequency	500 Hz
Overvoltage protection	+V.LIM and +OVP	Positive overvoltage protection activation point	110 % of the rated value
	-V.LIM and -OVP	Negative overvoltage protection activation point	110 % of the rated value
	LIMIT / OVP	Mode	LIMIT
Overcurrent protection	+I.LIM and +OCP	Positive overcurrent protection activation point	110 % of the rated value
	-I.LIM and -OCP	Negative overcurrent protection activation point	110 % of the rated value
	LIMIT / OCP	Mode	LIMIT
The protective action that is carried out when OVP or OCP is activated		Power off or output off	OUT OFF
Preset memory	A, B, and C memory entries for CV mode A, B, and C memory entries for CC mode		A, B, and C memory entries for CV mode
MEASURE	FUNC		DC
	APERTURE		0.1 s
	TRIG SOURCE		AUTO
	TRIG DELAY		0 s
CONFIG settings	MODE		
	RESPONSE		
	SENSING		
	SIGNAL SOURCE		
	POWER ON		
	SYNCHRONOUS		The same as the CONFIG factory default settings
	TRIGGER SLOPE		
	EXT OUTPUT ON/OFF		 p. 86
	MEMORY		
	KEYLOCK		
	BEEP		
PARALLEL			

¹The same for memory numbers 0 to 9. Each memory entry name is UNTITLED.

If you use **CONFIG** to change settings to DEFAULT (the default values), memory is not affected. If you reset the PBZ to its factory default settings, all the memory entries are cleared. (This manual differentiates between the terms “default values” and “factory default settings.”)

Sequences

Item			Factory default setting
Program	SELECT	Program number.	1
	TITLE	Program name.	UNTITLED
	POLARITY	Bipolar/unipolar mode.	Bipolar mode
	MODE	CV/CC mode.	CV
	LOOP	The number of times that the program will repeat.	1
DC signal and triggers	TIME	Step execution time.	1 s
	DC	DC signal setting.	0 V
	OUTPUT	Output: on/off.	ON
	TRIG OUT	Whether trigger signals are generated when steps begin (ON) or not (OFF).	OFF
	TRIG IN	Whether the PBZ enters the trigger signal input standby state when steps begin (ON) or does not (OFF).	OFF
AC signal amplitude and frequency	AC	The same as the AC signal settings shown in "Operation mode and signal sources" on page 168.	OFF
	FUNC		 Sine wave
	AMPL		0 Vp-p
	FREQ		1000 Hz
	PHASE		0 deg
	DUTY		50 %
DC signal ramp transition	DC RAMP	Whether the DC voltage changes linearly from the start value to the stop value (ON) or not (OFF).	OFF
	START	The start value.	0 V
	STOP	The stop value.	0 V
AC signal amplitude sweep	AMPL SWEEP	Whether the AC signal sweeps from the start amplitude to the stop amplitude (ON) or not (OFF).	OFF
	START	Start amplitude.	0 Vp-p
	STOP	Stop amplitude.	0 Vp-p
AC signal frequency sweep	FREQ SWEEP	The same as the AC signal settings shown in "Operation mode and signal sources" on page 168.	OFF
	MODE		LINEAR
	START		1000 Hz
	STOP		1000 Hz

If you use **CONFIG** to change settings to DEFAULT (the default values), saved sequences are not affected. If you reset the PBZ to its factory default settings, all the sequences are cleared. (This manual differentiates between the terms "default values" and "factory default settings.")











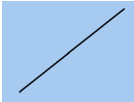

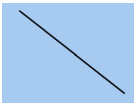

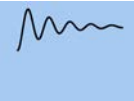
Parallel operation, synchronization feature, and other settings

Item			Factory default setting
Parallel operation	MASTER/SLAVE	Master unit or slave unit	MASTER
	UNIT	The number of units	1
Synchronization feature	OPERATION	Master unit, slave unit, or slave end unit	OFF
Preset memory	MEMORY RECALL	Memory load method	2KEY
Key lock	KEY LOCK	Key lock on or off	OFF
	LEVEL	Security level	3
Buzzer	BEEP	Buzzer on or off	ON

Interfaces

Item			Factory default setting
INTERFACE	TYPE	Interface type	USB
	ERR TRACE	Debug trace	OFF
GPIB	GPIB ADDRESS	GPIB address	1
	BAUDRATE	Baud rate	19200
RS232	DATA BIT	RS232C data length	8
	STOP BIT	RS232C stop bit	1
	PARITY BIT	RS232C parity	NONE (fixed)
	X-FLOW	RS232C flow control	ON

User-defined arbitrary waveforms

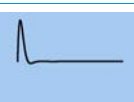
Item	Factory default setting	Item	Factory default setting
ARB1	Ramp (POS) (Rising)  [-1, +1]	ARB9	Half wave (POS) Half period of a sine wave (positive)  [0, +1]
ARB2	Ramp (NEG) (Falling)  [-1, +1]	ARB10	Half wave (NEG) Half period of a sine wave (negative)  [-1, 0]
ARB3	Exponential (RISE) (Rising)  [0, +1]	ARB11	2nd order step response (damping factor $\zeta = 0.1$)  [0, +1]
ARB4	Exponential (FALL) (Falling)  [0, +1]	ARB12	2nd order step response (damping factor $\zeta = 0.2$)  [0, +1]
ARB5	Half-wave rectification (POS) Half-wave rectification of a sine wave (positive)  [0, +1]	ARB13	2nd order step response (damping factor $\zeta = 0.7$)  [0, +1]
ARB6	Half-wave rectification (NEG) Half-wave rectification of a sine wave (negative)  [-1, 0]	ARB14	2nd order impulse response (damping factor $\zeta = 0.1$)  [-1, +1]
ARB7	Full-wave rectification (POS) Full-wave rectification of a sine wave (positive)  [0, +1]	ARB15	2nd order impulse response (damping factor $\zeta = 0.2$)  [-1, +1]
ARB8	Full-wave rectification (NEG) Full-wave rectification of a sine wave (negative)  [-1, 0]	ARB16	2nd order impulse response (damping factor $\zeta = 0.7$)  [-1, +1]

B Output impedance

PBZ20-20

- Output impedance when the output is off
120 k Ω (typical value)
- Output impedance when the output is on

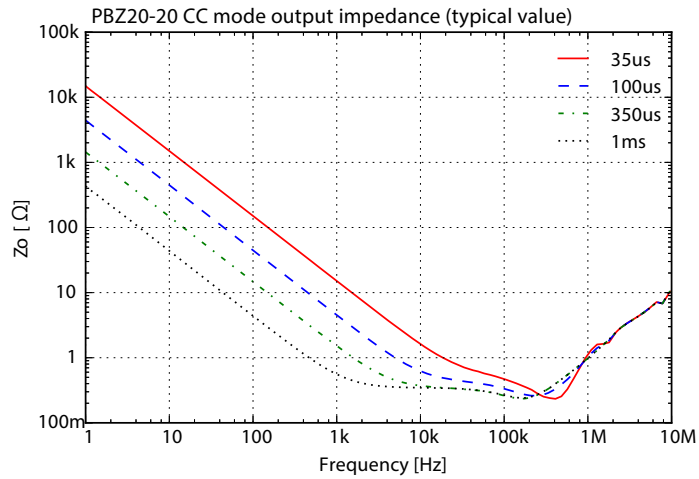
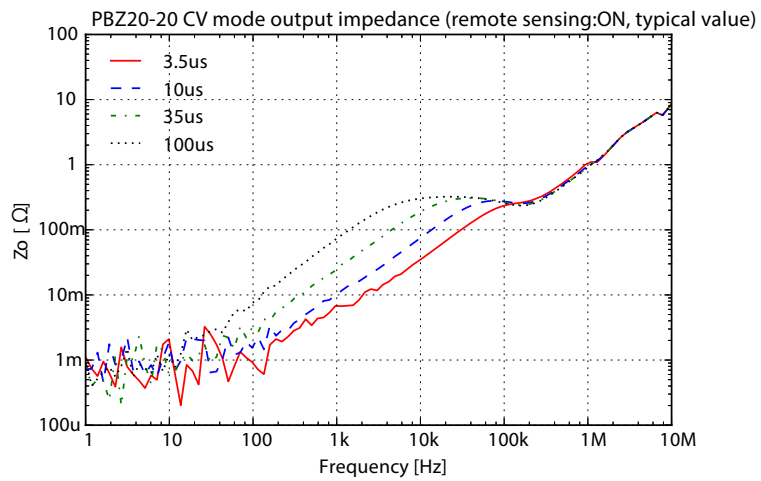

App

PBZ40-10

- Output impedance when the output is off
220 k Ω (typical value)
- Output impedance when the output is on

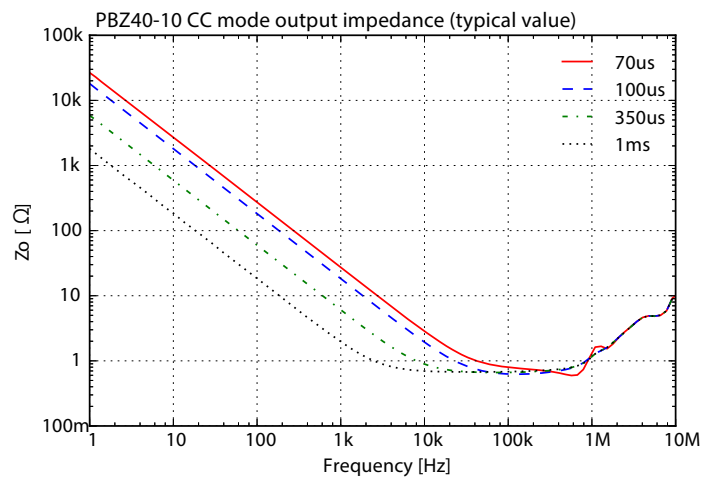
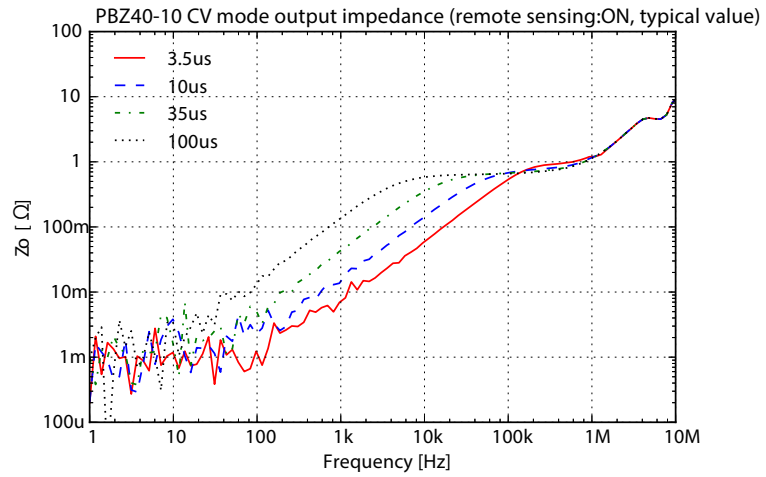

PBZ60-6.7

- Output impedance when the output is off
320 k Ω (typical value)
- Output impedance when the output is on

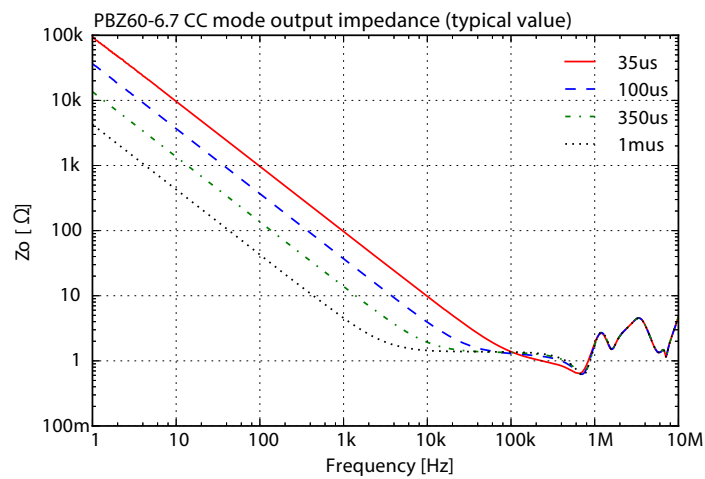
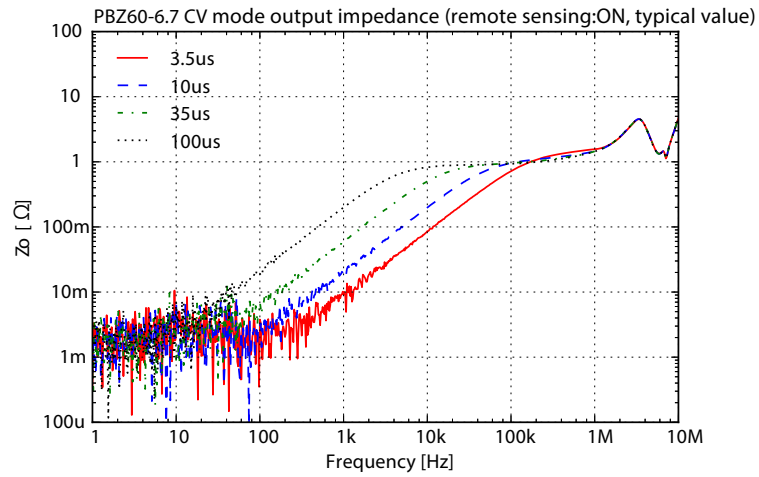

PBZ80-5

- Output impedance when the output is off
420 k Ω (typical value)
- Output impedance when the output is on

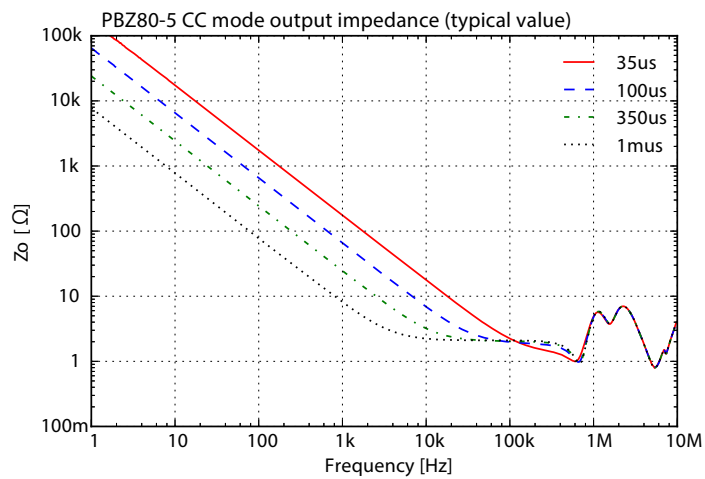
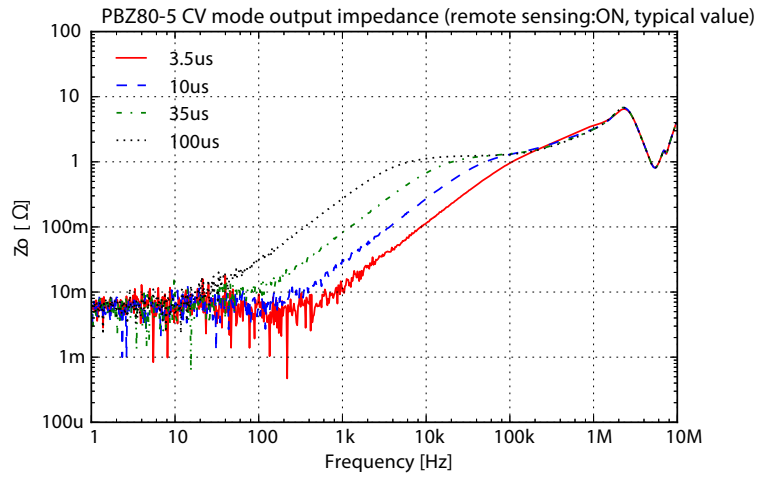

C Troubleshooting

This section introduces troubleshooting measures. Typical symptoms are listed. Check whether any of the items listed below apply to your case. In some cases, the problem can be solved quite easily.

 p. 168

If none of the items apply to your case, we recommend that you initialize the PBZ to its factory default settings. If the remedy does not correct the problem, Contact your Kikusui agent or distributor.

The power does not turn on.

Symptom	Items to check and possible remedy	
The PBZ does not operate when the POWER switch is turned on.	Is the power cord broken?	p. 20
	Replace the power cord with the same type of power cord.	p. 18
An error number (E901) is displayed after the self-test.	An error was detected in the internal system. Restart the PBZ.	p. 22

Unable to carry out panel operations.

Symptom	Items to check and possible remedy	
Unable to operate the panel keys.	Is the key lock icon displayed on the screen?	p. 14
	Release the panel operation lock.	p. 72
	Is the RMT icon displayed in the screen's status display area?	p. 73
The PBZ does not switch to local mode even when I press the LOCAL key.	Is the PBZ being controlled via the RS232C, GPIB, USB, or LAN interface?	
	To control the PBZ from the panel, press the LOCAL key to switch to local mode.	
The PBZ does not switch to local mode even when I press the LOCAL key.	Was a local lockout (LLO) command sent through the communication interface?	–
	Use a communication command to clear the local lockout (LLO) command. For details, see the communication interface manual.	

Output does not turn on.

Symptom	Items to check and possible remedy	
Output does not turn on when the POWER switch is turned on.	Did you press the OUTPUT key?	p. 57
	Press the OUTPUT key.	
Output does not turn on when I press the OUTPUT key.	Have you set the PBZ to turn output on when the POWER switch is turned on?	p. 21
	In the CONFIG settings, set POWER ON>OUTPUT to ON.	p. 87
Output does not turn on even when I press the OUTPUT key.	Are you using an external contact to turn output on and off?	p. 138
	Use the external contact to turn output on.	
Output does not turn on even when I press the OUTPUT key.	Is the external control logic setting for turning output on and off correct?	p. 89
	In the CONFIG settings, set EXT OUTPUT ON/OFF>POLARITY to HIGH (output turns on when the contact enters the break state).	

An alarm or an error is displayed when the OUTPUT key is pressed.

Symptom	Items to check and possible remedy	See
A protection feature is activated when I press the OUTPUT key.	Is the OVP activation point set to a value that is less than or equal to the output voltage? Set the OVP activation point to a value that exceeds the output voltage.	p. 67
	Is the OCP activation point set to a value that is less than or equal to the output current? Set the OCP activation point to a value that exceeds the output current.	
	Is the remote sensing feature turned on? When you are not using remote sensing, set SENSING to OFF in the CONFIG settings.	p. 86
	Is the internal temperature too high? The overheat protection feature has been activated. Check the operating environment. The dust filter may be clogged, or the fan may be damaged.	p. 66 p. 154
An error number (E001) is displayed when I press the OUTPUT key.	The input voltage is low, so the PBZ can not function properly. Turn the POWER switch off, and then check the voltage of the input power supply.	p. 23 p. 180

The output does not turn off immediately when the OUTPUT key is pressed.

Symptom	Items to check and possible remedy	See
The output does not turn off immediately when I press the OUTPUT key.	Have you set the soft stop feature?	p. 42
	If the PBZ is currently in the middle of a soft stop, press the OUTPUT key one more time.	p. 58

Unable to set the output voltage or output current correctly.

Symptom	Items to check and possible remedy	See
The specified value is not entered.	When an AC signal is superimposed on the DC signal (AC ON), does the sum of the DC setting, the FINE setting, and the AMPL setting exceed the rated value? Change the value of (the DC setting + the FINE setting) and the AMPL setting so that the sum of these values is less than or equal to the rated value.	p. 46

Unable to set sequences (DC signal ramp transitions, AC signal amplitude sweeps, and AC signal frequency sweeps) correctly.

Symptom	Items to check and possible remedy	See
I can't set DC signal ramp transitions, AC signal amplitude sweeps, and AC signal frequency sweeps correctly.	Divide the steps so that the step time for each step is 1000 seconds or less.	p. 132

The internal signal source's AC signal cannot be turned on.

Symptom	Items to check and possible remedy	See
The internal signal source's AC signal cannot be turned on.	When an AC signal is superimposed on the DC signal (AC ON), does the sum of the DC setting, the FINE setting, and the AMPL setting exceed the rated value? Change the value of (the DC setting + the FINE setting) and the AMPL setting so that the sum of these values is less than or equal to the rated value.	p. 44

The output is unstable.

Symptom	Items to check and possible remedy	See
The output voltage or output current fluctuates.	Is the remote sensing feature turned on? When you are not using remote sensing, set SENSING to OFF in the CONFIG settings.	p. 86
	Does the sensing cable or load cable have poor contact, or is the cable broken? Turn the POWER switch off and check the wiring.	p. 29
The output voltage is offset from the voltage that the PBZ was generating when it was turned on.	Has 30 minutes passed since the power was turned on? Warm up the PBZ for at least 30 minutes.	–
There is a large amount of output noise during external control.	Are you using two-wire shielded cables or twisted pair cables to connect to the external voltage or external resistance? Use two-wire shielded cables or twisted pair cables to connect the PBZ to the external voltage or external resistance; keep the cables as short as possible.	p. 136 p. 137
	Does the external voltage produce a lot of noise? Use an external voltage that produces as little noise as possible.	

The output response is slow.

Symptom	Items to check and possible remedy	See
The output voltage or output current response is slow.	You can set the response. Use the CONFIG settings to set the response.	p. 86

There are glitches in the output.

Symptom	Items to check and possible remedy	See
There are glitches in the output waveform when output is turned on or at the transition between sequence steps.	When you combine signal sources, glitches may be produced because of the differences in the responses of the signal sources. You can reduce these glitches by increasing the response setting. You can also eliminate output glitches by registering the necessary waveform as a user-defined arbitrary waveform and selecting just the AC signal for the signal source.	p. 38

Settings cannot be loaded from preset memory.

Symptom	Items to check and possible remedy	See
Settings cannot be loaded from preset memory.	Have you switched the PBZ from bipolar mode to unipolar mode? Are you loading a memory entry that was saved in bipolar mode when the PBZ is in unipolar mode? Set the PBZ to bipolar mode. You cannot load memory entries that were saved in bipolar mode when the PBZ is in unipolar mode.	p. 86

D List of Error Messages

Error number	Message	Description
E001	INPUT VOLTAGE	The input voltage is outside of the rated range when the PBZ is turned on.
E101	CALIBRATION DATA	An error was detected in the calibration values.
E102	EEPROM DATA	An error was detected in the backup data.
E901	INTERNAL ERROR	An error was detected in the internal system.

Error number	Message	Description
W001	OUTPUT-ON state	The operation could not be performed because output is on.
W002	REMOTE-OFF state	The operation could not be performed because output has been turned off through remote control signals.
W003	PROTECTION state	The operation could not be performed because an alarm is occurring.
W004	KEY LOCK state	The operation could not be performed because keys are locked.
W005	SYNC SLAVE state	The operation could not be performed because the PBZ is operating in synchronization and it is a slave unit or a slave end unit.
W006	SYNC FAIL	synchronization failed.
W007	SYNC CTRL state	The operation could not be performed because the PBZ is operating in synchronization.
W008	SOFT START state	The operation could not be performed because the PBZ is executing a soft start.
W009	SOFT STOP state	The operation could not be performed because the PBZ is executing a soft stop.
W011	REMOTE state	The operation could not be performed because the PBZ is in remote mode.
W012	LOCAL LOCK OUT state	The operation could not be performed because the PBZ received a local lockout (LLO) command.
W021	SEQ.EXECUTION state	The operation could not be performed because a sequence program is executing.
W031	SLAVE mode	The operation could not be performed because the PBZ is a slave unit.
W101	POLARITY setting	The operation could not be performed because the bipolar/unipolar mode setting is not correct.
W102	CV/CC setting	The operation could not be performed because the CV/CC mode setting is not correct.
W103	AC AMPL setting	The operation could not be performed because the PBZ's AC amplitude setting is not correct.
W104	AC OFF setting	The operation could not be performed because the PBZ is in the setting of AC OFF.
W211	PROGRAM is empty	No step is edited in a program.
W221	SCRIPT is empty	A script has no program to execute.
W222	SCRIPT syntax	A script has syntax errors.

E Options

The PBZ has the following options. For information about options, contact your Kikusui agent or distributor.

Rack mount brackets

See p. 19

A bracket that you can use to rack mount the PBZ.

Model	Type of rack
KRB3-TOS	For EIA inch racks
KRB150-TOS	For JIS millimeter racks; blank panel included

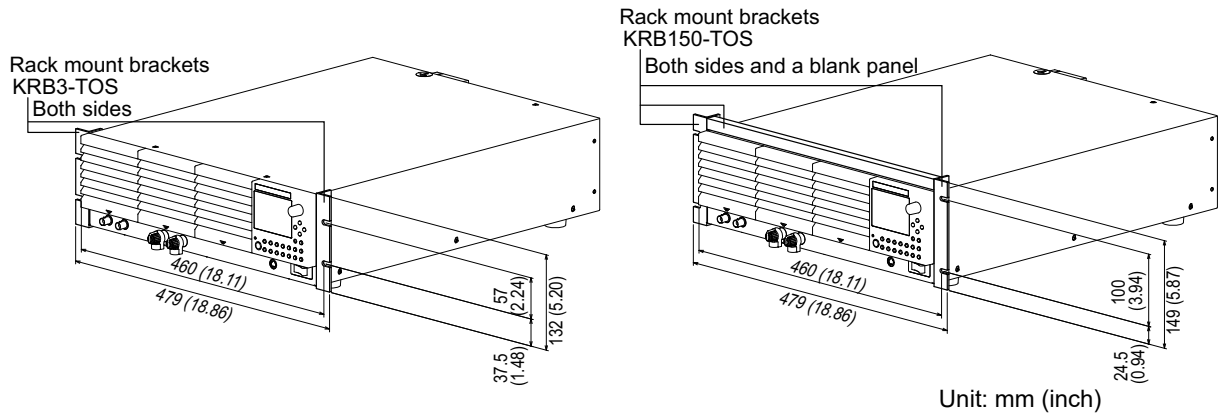

App

Vertical stand

A stand that you can use to keep the PBZ in a vertical orientation.

Model	Dimensions
VS01	580 (22.83) W × 245 (9.64) H × 350 (13.78) D mm (inch); stand only (maximum dimensions)

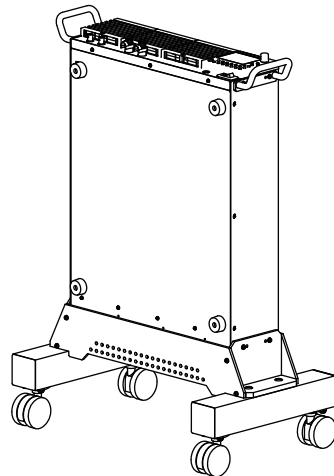

Parallel operation kit

See p. 142

You can use this kit to connect two PBZs in parallel operation. Use the dedicated connection bars to connect the OUTPUT terminals of the two same-model PBZs.

Model	Type of parallel operation kit
PK01-PBZ	For bench-top
PK02-PBZ	For EIA inch racks
PK03-PBZ	For JIS millimeter racks

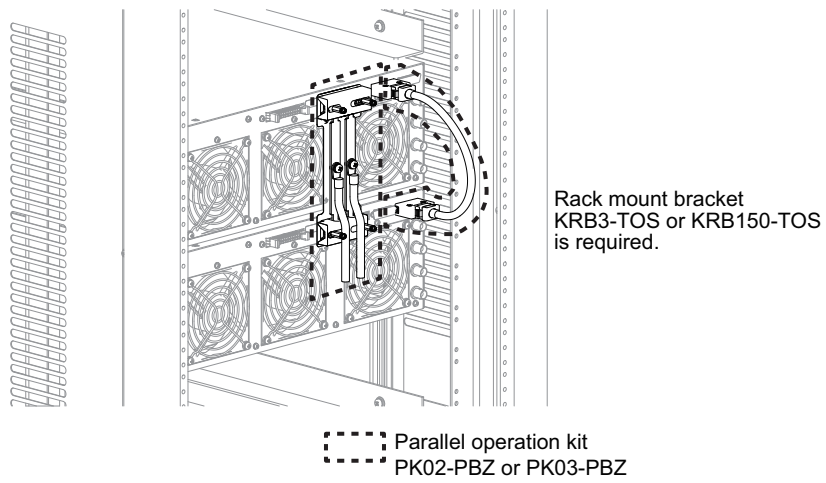
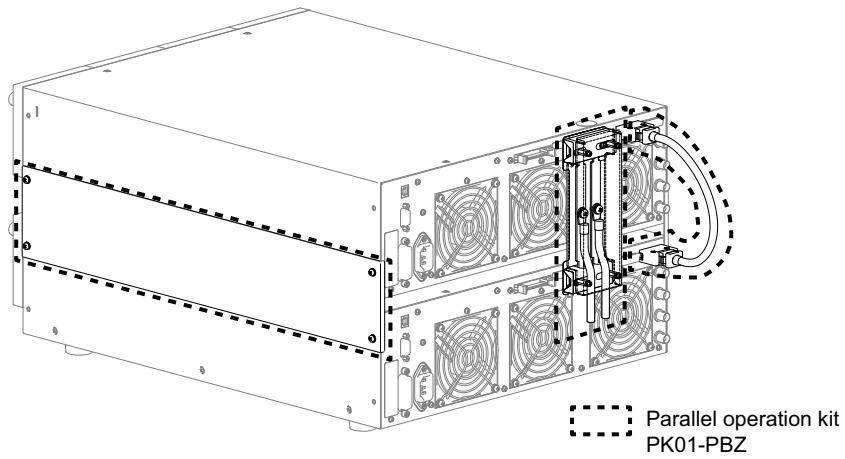

Low inductance cable

This product is a low-inductance load cable that suppresses voltage drops that occur when current changes at a high rate.

The optional M8 terminal connection kit is required.

	TL01-PLZ	TL02-PLZ	TL03-PLZ
Full length* ¹	50 cm	1 m	2 m
Inductance value ²	140 nH	150 nH	200 nH

¹Between the insulation caps

²at 100 kHz

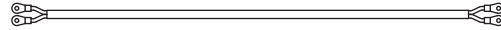

M8 terminal connection kit

This kit (OP01-PBZ-A) is for connecting crimping terminals for M8 to the OUTPUT terminal block.

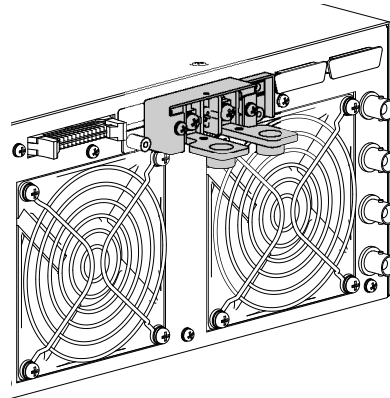

This page is intentionally blank.

INDEX

Numerics	
10 MHz IN terminal	15
10 MHz OUT terminal	15
1KEY	78
2KEY	78
A	
A key	13
ABC STORE key	13
AC INPUT	15
AC key	13
AC ON/OFF key	13
AC ON/OFF setting	47
AC signal	38
accessories	18
alarms, clearing	66
ALM CLR key	13
AMPL setting	46
auxiliary output terminals	28
B	
B key	13
backup data error	22
binding post cover	28
bipolar mode	34
bipolar/unipolar mode	34
breaker, tripping	140
C	
C key	13
calibration value error	22
CONFIG key	13
constant current source	35
constant voltage source	35
CURSOR	13
CV/CC mode	34
D	
DC key	13
DC setting	41
DC signal	38
default settings, list	168
default values, resetting to	168
DEL key	13
delay	62
DUTY setting	48
E	
EDIT key	13
ENTER key	13
error number, what to do	22
EXT SIG IN terminal	12
external signal sources	38
F	
factory default settings	168
FINE setting	41
firmware version	2
FREQ setting	47
FUNC setting	45
I	
I MON terminal	12
I.LIM	64
INS key	13
internal signal sources	38
internal system error	22
J	
J1 connector	15
K	
k key	13
key lock	72, 90
KEY LOCK key	13
L	
load cables	26
LOCAL key	13
M	
m key	13
master unit	142
MEASURE key	13
measurement start trigger	62
MODE setting	49
N	
NUM key	13
O	
OCP (OUTPUT-OFF)	64
OCP (POWER-OFF)	64
OUTPUT key	13
OUTPUT terminal cover	25
OUTPUT terminals	12, 15
overcurrent protection	64
overvoltage protection	64
OVP (OUTPUT-OFF)	64
OVP (POWER-OFF)	64

P

parallel operation	91, 142
parallel operation kit	182
PARALLEL terminals	15
PHASE setting	48
power cord	20
power limit (sink power)	28, 65
POWER switch	12
precautions to prevent damaging the load	21
preset memory	76
programs (PROGRAM)	96
PROT key	13

R

rack mount options	181
rack mounting	19
RECALL key	13
REMOTE connector	12
remote sensing	29, 86
Removing the rubber feet	19
response	81, 86
RUN/PAUSE key	13

S

scripts (SCRIPT)	96
sensing terminals	15
Serial number	15
setup memory	76
SHIFT key	13
slave unit	142
soft start and soft stop	58
START and STOP settings	50
steps (STEP)	96
STOP key	13
STORE key	13
SWEEP setting	49
synchronization feature	147

T

TIME setting	49
TRIG IN terminal	15
TRIG OUT setting	51
TRIG OUT terminal	15
TRIG OUT terminal, function of	51

U

unipolar mode	34
---------------------	----

V

V.LIM	64
version	2

If you find any misplaced or missing pages in the manuals, they will be replaced. If the manual gets lost or soiled, a new copy can be provided for a fee. In either case, please contact your Kikusui agent or distributor. At that time, inform your agent or distributor of the "Part No." written on the front cover of this manual.

Every effort has been made to ensure the accuracy of this manual. However, if you have any questions or find any errors or omissions, please contact your Kikusui agent or distributor.

After you have finished reading this manual, store it so that you can use it for reference at any time.

KIKUSUI ELECTRONICS CORP.

1-1-3 Higashiyamata, Tsuzuki-ku, Yokohama,
224-0023, Japan

Tel: +81-45-482-6353

Fax: +81-45-482-6261

www.kikusui.co.jp/en

